

In-Service Measurement of the OSNR in ROADMs-based Networks

Abstract

Optical networks using reconfigurable optical add-drop multiplexers (ROADMs) present a challenge for optical signal-to-noise ratio (OSNR) testing. Proposed is a new method for measuring the in-band OSNR based on a high resolution optical spectrum analyzer using a new optical polarization splitting method.

Introduction

The OSNR is the key performance parameter in optical networks that predicts the bit error rate (BER) of the system. OSNR is conventionally obtained by measuring the total signal power in the channel passband and the amplified spontaneous emission (ASE) noise levels in the gaps between the optical channels. This is called the out-of-band OSNR. In transparent reconfigurable wavelength division multiplexing (WDM) networks, the ASE noise floor undergoes a noise shaping by the in-line optical filters of the ROADMs suppressing the noise between optical channels. The out-of-band OSNR will overestimate the 'true' OSNR. By measuring the noise power inside the optical channel passband it is possible to obtain the 'true' OSNR which is called the in-band OSNR, see Figure 1.

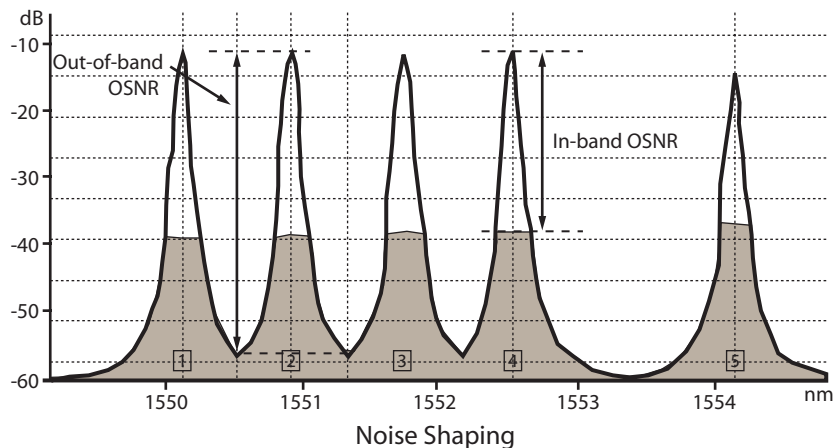

Figure 1 Difference between conventional out-of-band OSNR and in-band OSNR measurements

Written by:

Wolfgang Moench
 Communications Test & Measurement
 JDSU

Julia Larikova
 Optical Transport R&D
 Tellabs Inc



To get access to the in-band noise level several methods using the polarization-nulling technique have been proposed.^{1, 2} The polarization-nulling technique is considered sensitive to polarization mode dispersion (PMD) effects, especially in high speed networks.

In this paper we demonstrate a novel technique to overcome the PMD sensitivity based on polarization splitting and simultaneous measurement of both states of polarization (SOP) with a dual port OSA. This method is called the optical polarization splitting method (OPS). The OPS method can be used for in-service qualification of the optical signal performance during installation and maintenance of reconfigurable ROADM-based optical WDM networks.

Principle of operation

The underlying concept of the polarization-nulling technique is that the modulated signals consist of arbitrary polarized light, while the ASE noise consists of non-polarized light. Figure 2 shows the operating principle of the proposed OPS method.

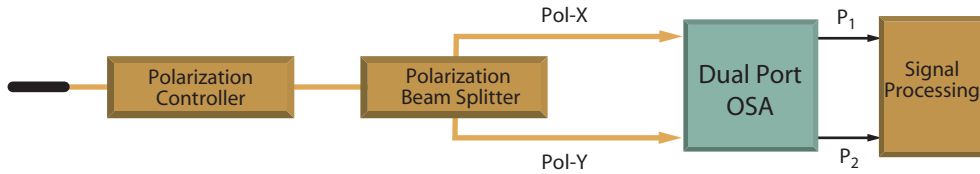

Figure 2 Schematic diagram of the proposed OPS measurement technique

An adjustable polarization controller (PC) is used to find the minimum and the maximum optical power by aligning to the state of polarization of the signal or its orthogonal state to the polarizer. It is possible to suppress the polarized optical signal (P_S) and get access to the non-polarized in-band noise (P_N). A high performance polarization beam splitter (PBS) is used to split the signal into two arms, Pol-X and Pol-Y, both being linearly polarized in orthogonal states. The dual port high resolution optical spectrum analyzer (OSA) can simultaneously measure both arms (P_1 and P_2) of the PBS containing the suppressed signal (P_{S1} , P_{S2}) and the ASE noise. A measurement of the in-band OSNR will need multiple scans over a selected wavelength range with different settings of the PC to find the maximum suppression of the signal. The minimum of P_1 and P_2 indicates P_N , with the signal being suppressed, whereas the sum of P_1 and P_2 shows $P_S + P_N$. At the end of the measurement the in-band OSNR values of all channels are shown based on the following equations:

$$P_1 = (P_{S1} + \frac{1}{2} P_N) \quad (1)$$

$$P_2 = (P_{S2} + \frac{1}{2} P_N) \quad (2)$$

$$P_S = P_{S1} + P_{S2} \quad (3)$$

$$P_1 + P_2 = P_S + P_N \quad (4)$$

$$P_N = \text{Min}(P_1, P_2) \quad (5)$$

$$\begin{aligned} \text{OSNR} &= P_S / P_N \\ &= (P_1 + P_2) - \text{Min}(P_1, P_2) / \text{Min}(P_1, P_2) \quad (6) \end{aligned}$$

Under the influence of PMD, the signal will depolarize with a frequency-dependent SOP, causing a noise power overestimation and signal power under-estimation due to the linear polarizer aligned with a single SOP. Our proposed method shows high PMD robustness due to three factors:

1. Both SOP are simultaneously measured avoiding any underestimation of the total aggregate power of the signal and the ASE.
2. An ultra narrow-band filter, with 7.5 GHz bandwidth, is used to minimize depolarization effects.
3. An adaptive off-center measurement is employed to measure the noise level at the optical signal slope, reducing the effect of overestimating the ASE noise.

With the combination of a wavelength scanning spectrum analyzer and the alignment of the SOP by the adjustable polarization controller, it is possible to measure the in-band OSNR of all optical channels of a dense wavelength division multiplexing (DWDM) network with reduced sensitivity to PMD.

Experiments and results

The performance of the proposed OPS method was evaluated in a high speed DWDM system at Tellabs in Chicago. Figure 3 shows the experimental setup using different signal sources (Tx) with 10 G NRZ-ook, 43 G-NRZ-DPSK, 43 G-RZ-DPSK and 43 G-PSBT modulation.

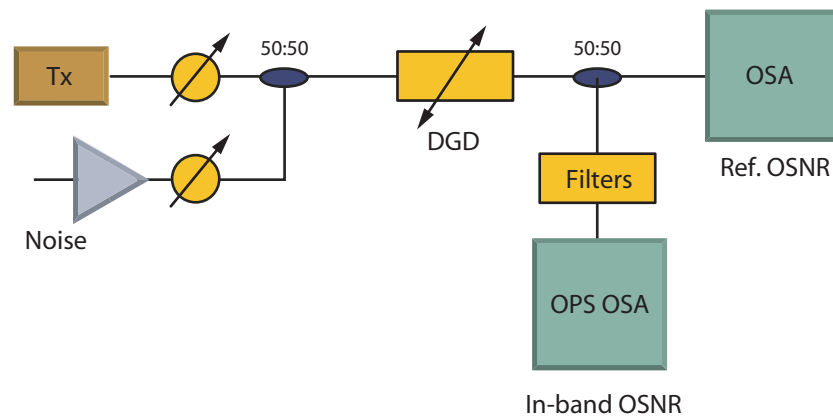

Figure 3 Experimental setup

The OSNR could be adjusted between 10 dB and 30 dB, using two attenuators and a 3 dB coupler combining an ASE noise source and the modulated signal. A PMD emulator was inserted to simulate the effects of differential group delay (DGD) in the range of 0 to 50 ps. To simulate the effect of a ROADM network, an optical filter bank was inserted (Filters). The 0.5 dB filter bandwidth could be modified between 32 GHz and 23 GHz to emulate the bandwidth narrowing effect due to filter cascading of 11 and 22 ROADMs. As a reference value, the OSNR was measured with a standard OSA with a 3 dB coupler in parallel to the ROADM filters.

Figure 4 shows the measurement result of the proposed OPS-method for different modulation schemes without PMD. The measurement error was smaller than 0.5 dB for OSNR varying from 10 dB to 30 dB.

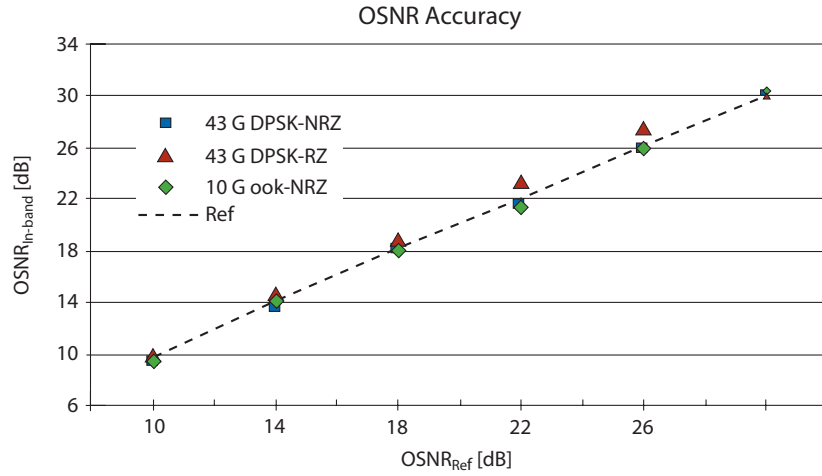

Figure 4 OSNR measured by OPS-method for different modulation rates without PMD

Figure 5 shows the measurement accuracy of 43 G signals with DGD in the range of 0 to 20 ps. The measurement accuracy for the 43 G-NRZ signals was in the range of 0.5 dB.

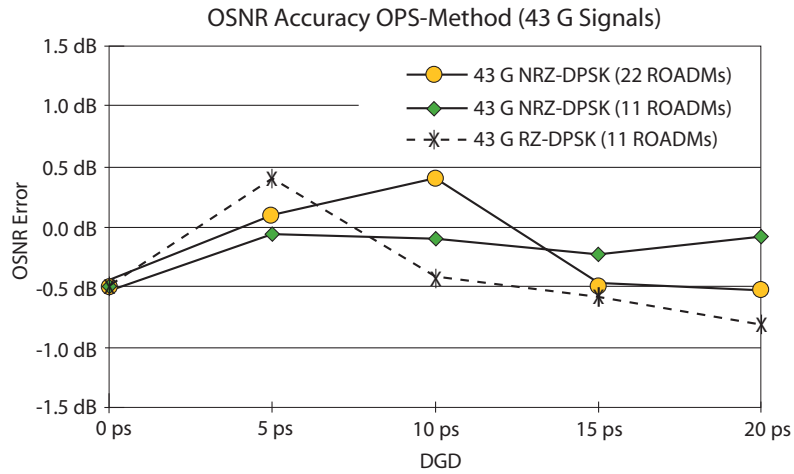

Figure 5 OSNR measurement error for 43 G signals with OPS-method at DGD up to 20 ps

Figure 6 shows the measurement results of the OPS method for 10 G signals with DGD up to 50 ps. The measurement accuracy was in the range of 0.5 dB.

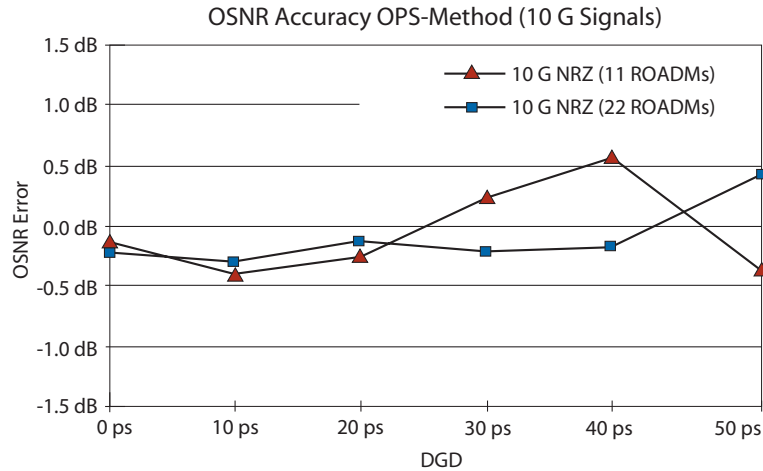

Figure 6 OSNR measurement error for 10G signals with OPS-method at DGD up to 50 ps

Summary

A new technique for in-service measurement of the in-band OSNR in next generation optical DWDM networks is proposed. The OPS method combines the advantage of a conventional high resolution OSA and the improved polarization-nulling technique with polarization splitting for 'true' in-band OSNR measurement. Using simultaneous measurement of both SOP, together with adaptive narrow band off-center filtering gives high robustness to PMD effects. Measurements at data rates up to 43 G have shown an accuracy of 0.5 dB. A further advantage of the OPS method is that all WDM channels can be measured simultaneously.

References

¹Man-Hong Cheung, "PMD-insensitive OSNR monitoring based on polarization-nulling with off-center narrow-band filtering", IEEE Photon. Technol. Lett., vol. 16, No. 11 Nov. 2004

²L.-S. Yan, "Simultaneous monitoring of both optical signal-to-noise ratio and polarization-mode dispersion using polarization scrambling and polarization beam splitting", Journal of Lightwave Techn., vol. 23, No. 19, Oct. 2005

All statements, technical information and recommendations related to the products herein are based upon information believed to be reliable or accurate. However, the accuracy or completeness thereof is not guaranteed, and no responsibility is assumed for any inaccuracies. The user assumes all risks and liability whatsoever in connection with the use of a product or its application. JDSU reserves the right to change at any time without notice the design, specifications, function, fit or form of its products described herein, including withdrawal at any time of a product offered for sale herein. JDSU makes no representations that the products herein are free from any intellectual property claims of others. Please contact JDSU for more information. JDSU and the JDSU logo are trademarks of JDS Uniphase Corporation. Other trademarks are the property of their respective holders. ©2007 JDS Uniphase Corporation. All rights reserved. 30149228 000 1107 ECOC.WP.FOP.TM.AE

Test & Measurement Regional Sales

NORTH AMERICA TEL: 1 866 228 3762 FAX: +1 301 353 9216	LATIN AMERICA TEL: +55 11 5503 3800 FAX: +55 11 5505 1598	ASIA PACIFIC TEL: +852 2892 0990 FAX: +852 2892 0770	EMEA TEL: +49 7121 86 2222 FAX: +49 7121 86 1222	www.jdsu.com/test
---	--	---	---	--