

# Xgig® Expert Cross-Port Analysis

## Overview

The Cross-Port Analysis feature tracks frames as they traverse the network when captured across multiple analyzers. It provides latency timing statistics by analyzer port and identifies several network behavioral errors, including out-of-order frame delivery and potential frame losses, modified end of frame (EOF) values, latency thresholds, and thresholds for pending, queued frames within the network.

Cross-port functionality is available for Fibre Channel, serial attached SCSI (SAS), and Gigabit Ethernet physical layers. The automatic detection and configuration requires no input from users. The complex nature of tracking frames in traces using this feature may add significant time to the total trace processing time, although, typically less than 10 percent more.

Experts can also now track pathways automatically within embedded protocols, meaning that traces containing Fibre Channel over Ethernet (FCoE) on Gigabit Ethernet and a Fibre Channel port with related frames will be included in the Cross-Port Analysis. Even though the physical layers are dissimilar, the embedded device IDs and cyclic redundancy check (CRC) values are the same and currently include the FCIP, Internet Fibre Channel (iFCP), and FCoE protocols. If a frame appears on two or more ports within the network, measurements will be available for each instance in the same order that the frames traversed the network.

For example, consider a network with four analyzers connected at different analysis points, as illustrated in Figure 1.

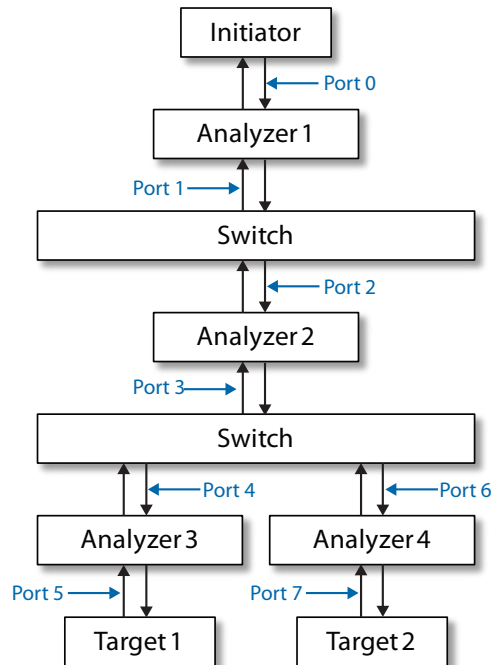

Figure 1. A network with four analyzers connected at different analysis points

In Figure 1, the Xgig Expert detects several pathways for the following port pairs:

1. Port 0 to Port 2
2. Port 2 to Port 4
3. Port 3 to Port 1
4. Port 2 to Port 6
5. Port 5 to Port 3
6. Port 7 to Port 3

Xgig Expert provides notification in the debug log for each cross-port path identified while processing the trace. This information is useful in the correlation and analysis of cross ports.

Note that in the previous example, Xgig Expert will not provide measurements for the following port paths:

- Port 0 to Port 4
- Port 0 to Port 6
- Port 5 to Port 1
- Port 7 to Port 1

These path measurements do not necessarily enhance measurements or analysis, and the individual paths without “hops” provide much more informative analysis points and simultaneously reduce complexity. If users require the Port 0 to Port 4 path, they can simply open the relevant port pairs in Expert versus the whole trace.

## Cross-Port Measurements and Experts

All metrics and experts are analyzed for each port pair and currently measure latency timings, pending frames, out-of-order frames, and network out-of-order frames.

Cross-port analysis allows the analyzer to uniquely identify several network error situations as well as congestion issues that otherwise remain undetectable.

Single-frame-sequence dropped frames in networks occur the most frequently and are invisible within protocols. For example, in a Fibre Channel storage area network (SAN), the initiator may transmit a Class 3 SCSI command frame (a single frame sequence) to a SCSI target. A dropped frame enroute to the target cannot be identified from a trace taken on the target port. It can only be identified through residual effects from the dropped frame, such as a SCSI timeout or target/logical unit number (LUN) reset. Traces taken only from the initiator port will appear as though the target did not respond to the command. It can be exceedingly difficult to manually identify dropped frames in a trace captured from both ports; however, the cross-port analysis algorithm performs this task automatically.

Expert provides three different views on the cross-port analysis results:

- **Debug View:** lists all the cross-port errors and warnings
- **Graph View:** plots the cross-port metrics over the time
- **Report View:** summarizes the cross-port metrics, errors, and warnings in a HTML report.

## Cross-Port Errors and Warnings in the Debug View

After loading a trace, Expert reports all the errors and warnings found in the Debug View table and sorts them by severity to highlight the critical issues. All the errors and warnings that the Cross-Port analysis detects have a Type cross port to enable viewing of all the cross-port symptoms together by sorting the table on the Type column.

The Expert Help file explains each error and warning in great detail that simplifies getting the full description of an error using the context menu “Full Description”. The help file describes 16 cross-port errors and warnings with the following being the most important:

- **Out-of-Order Frame by Src/Dst:** The single most important error with the highest severity. Figure 2 shows a stream of frames A, B, and C that the switch is re-ordering to A, C, B. Expert reports the error when it sees frame C on Analyzer 2 because it expects to receive B.

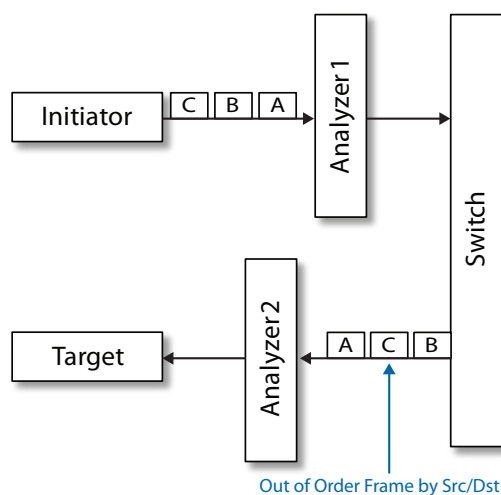

Figure 2. An out-of-order frame by Src/Dst

Typically, frames reported in these errors are not re-ordered instead the switch **drops** them, because Expert does not distinguish between out-of-order and dropped frames. Also, switches typically do not re-order frames from a single input port. Using TraceView can determine whether frames were dropped or re-ordered. Also, you can check for TCP retransmissions reported by Expert because dropped TCP frames will be retransmitted. Conversely, re-ordered TCP frames will not be retransmitted as the target will re-order them.

- **Cross-Port Latency Out of Bounds:** Expert measures the latency between all the frames from the input port to the output port and provides a warning when latency exceeds the default threshold of 5 milliseconds, which is configurable. High latency indicates severe network congestion. Note that Expert ignores frames that the switch drops in the latency measurement making calculations more meaningful.

- **Out-of-order Frame in Network:** This is typically a benign symptom that warns switch engineers who are interested in the behavior and is detected when two or more input streams merge into a single or multiple output stream. Expert warns when the sequence of frames coming out of the switch differs from the sequence input. Figure 3 shows the frames entering the switch in the sequence A, X, B, Y, but exiting as A, X, Y, B. Expert reports the error when it sees Y instead of B on the output port.

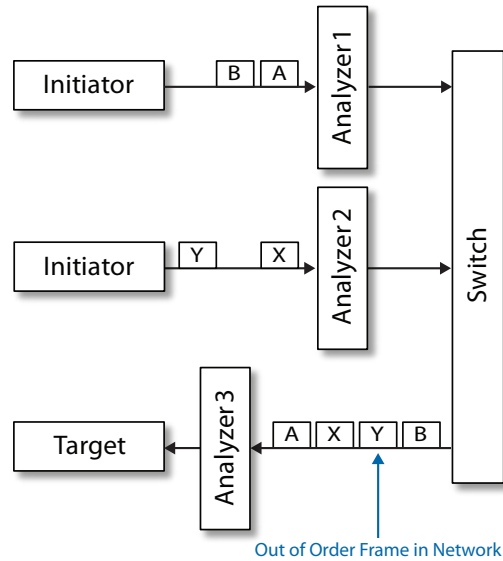

Figure 3. An Out-of-order frame in network

Although atypical, this warning becomes significant when frames from a single source take different paths through a network and are re-ordered by the last switch before being delivered to the target. Protocols such as Fibre Channel and FCoE do not support out-of-order frames, so their performance degrades rapidly when such network re-ordering occurs.

## Cross-Port Errors and Warnings in the Graph View

Similar to other metrics, cross-port metrics can be added to the Graph View by right-clicking inside the graph and selecting the context menu *Add Counter...* The Add Counters dialog pops up enabling you to select the *Cross-Port Analysis* in the Ports combo box as Figure 4 shows.

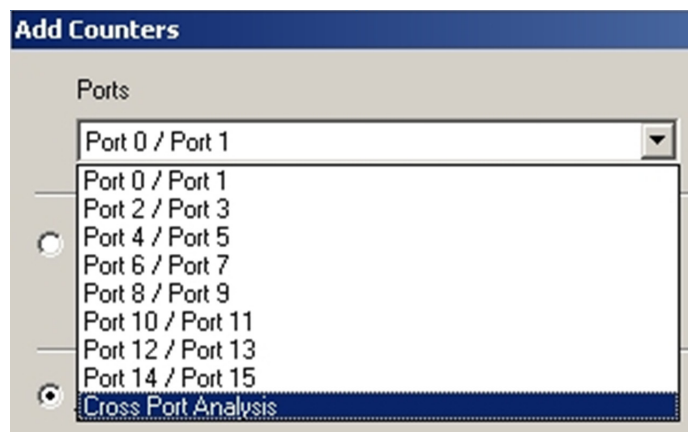

Figure 4. Enabling Cross-Port Analysis

After making this selection, the normal process of choosing the counter type and sub-type is the same as with any other protocol.

## Port Latency

Latency measurements and experts can help users identify congestion problems or to make bandwidth calculations. These measurements also show the elapsed time from when the start of frame (SOF) (Fibre Channel) or last byte of preamble (Gigabit Ethernet) enters the analyzer to when the SOF or preamble enters the next analyzer downstream. Typical networks and SAN configurations have consistent sub-millisecond latency. Multi-millisecond values or higher typically indicate severe congestion, unless a slow network exists between analyzer points, such as a 10 Mbps or asynchronous transfer mode (ATM) route between Gigabit Ethernet switches.

## Pending Frames

Pending frames (those sent into the network but not yet delivered to the next downstream port) metrics and experts can be used to identify congestion problems or delivery ordering within networks. A strong correlation exists in Fibre Channel between the number of pending frames and the credits available to the end points. Prior to the DCB technology, most Ethernet switches were of the cut-through variety and rarely buffered large numbers of frames. Conversely, the new DCB and FCoE switches have an input queue per priority and can buffer frames under congestion to prevent frame losses.

## Abnormal Frames (Out of Order)

Xgig Expert monitors frame ordering to facilitate in-order delivery across all ports. It can identify errors whenever a frame is re-ordered or dropped for a source/destination pair (Out-of-Order Frame by Src/Dst) or when the network reorders frames for multiple ports or destinations (Out-of-Order frame in Network).

## Cross-Port Errors and Warnings in the Report View

The Expert Report provides the most extensive cross-port analysis results. Users can create this report by enabling Cross-Port Analysis at Report Setup, as shown in Figure 5. The report, similar to the one shown in Figure 6, lists the measurement results of latency across the related links and counts the dropped frames as well.

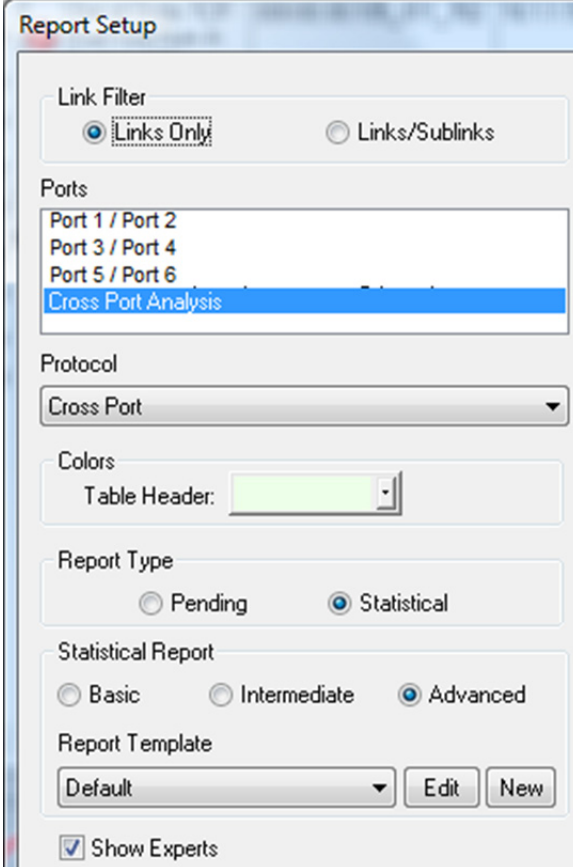

The screenshot shows the 'Report Setup' dialog box with the following configuration:

- Link Filter:**  Links Only,  Links/Sublinks
- Ports:** A list box containing 'Port 1 / Port 2', 'Port 3 / Port 4', 'Port 5 / Port 6', and 'Cross Port Analysis'. 'Cross Port Analysis' is selected and highlighted in blue.
- Protocol:** A dropdown menu set to 'Cross Port'.
- Colors:** A 'Table Header' color selection box showing a light green color.
- Report Type:**  Pending,  Statistical
- Statistical Report:**  Basic,  Intermediate,  Advanced
- Report Template:** A dropdown menu set to 'Default', with 'Edit' and 'New' buttons.
- Show Experts:**

Figure 5. Creating a report on Cross-Port Analysis

**Cross-Port - Port Latency**

Port / Port	Latency (Avg. $\mu$ s)	Latency (Min $\mu$ s)	Latency (Max $\mu$ s)	Latency (Total- $\mu$ s)
Port 1 -> Port 3    Switch 1 ->	33.742	0.915	93.824	8,162,092.625
Port 4 -> Port 2    Switch 1 <-	3.733	0.886	24.288	934,194.884
Port 3 -> Port 5    Switch 2 ->	6.782	1.017	1,199.820	1,640,365.089
Port 6 -> Port 4    Switch 2 <-	0.922	0.802	7.963	231,167.002
Any --> Any	11.295	0.802	1,199.820	10,967,819.599

**Cross-Port - Pending Frames**

Port / Port	Oldest Pending Frame ( $\mu$ s)	Pending Frames	Pending Frames (Min)	Pending Frames (Max)
Port 1 -> Port 3    Switch 1 ->	8.728	3.000	1.000	25.000
Port 4 -> Port 2    Switch 1 <-	3,176,368.380	350.000	1.000	356.000
Port 3 -> Port 5    Switch 2 ->	3,095,733.629	18.000	1.000	53.000
Port 6 -> Port 4    Switch 2 <-	3,177,013.393	94.000	1.000	99.000
Any --> Any	3,177,013.393	465.000	1.000	356.000

**Cross-Port - Src-Dst Out Of Order/Dropped Frames**

Port / Port	MB/Sec in Src-Dst Out Of Order frames	Bytes in Src-Dst Out Of Order frames	Src-Dst Out Of Order frame count	Bytes/Src-Dst Out Of Order Frame (Avg.)	Bytes/Src-Dst Out Of Order Frame (Min)	Bytes/Src-Dst Out Of Order Frame (Max)
Port 1 -> Port 3    Switch 1 ->	0.000	0.000	0.000	0.000	0.000	0.000
Port 4 -> Port 2    Switch 1 <-	0.523	1,756,775.000	350.000	5,019.357	69.000	9,009.000
Port 3 -> Port 5    Switch 2 ->	0.032	108,433.000	17.000	6,378.412	65.000	9,009.000
Port 6 -> Port 4    Switch 2 <-	0.203	682,833.000	94.000	7,264.181	69.000	9,009.000
Any --> Any	0.759	2,548,041.000	461.000	4,665.487	0.000	9,009.000

**Cross-Port - Network Out Of Order Frames**

Figure 6. Example of a Cross-Port Report

## Summary

Xgig Expert Cross-Port Analysis is a powerful tool for analyzing large-scale networks providing complete, end-to-end visibility into the network by tracking down traffic flows hop by hop. The Cross-Port Analysis feature enables users to evaluate network health, to measure key network performance parameters, such as latency and packet drop where reviewing individual traces was previously impossible, and to quickly identify performance bottlenecks.

### Test & Measurement Regional Sales

<b>NORTH AMERICA</b> TEL: 1 866 228 3762 FAX: +1 301 353 9216	<b>LATIN AMERICA</b> TEL: +1 954 688 5660 FAX: +1 954 345 4668	<b>ASIA PACIFIC</b> TEL: +852 2892 0990 FAX: +852 2892 0770	<b>EMEA</b> TEL: +49 7121 86 2222 FAX: +49 7121 86 1222	<b>WEBSITE: <a href="http://www.jdsu.com/test">www.jdsu.com/test</a></b>
---	--	---	---	--