



JDSU SmartID™ Advanced Coax Probes

Reduce repeat calls for Triple-Play and MoCA® issues with minimal investment and huge time savings.

Get the product that pays for itself in fewer than 6 months by reducing repeat trouble calls.

Verify and ensure high-quality coax with JDSU SmartID Advanced Coax Probes.

Used in conjunction with the JDSU DSAM^{XT} handheld meter, the SmartID quickly certifies subscriber coax topology, and identifies and locates physical layer coax impairments that affect both Triple-Play and multiroom Digital Video Recorder (DVR) (MoCA) services.

Increase customer satisfaction by reducing repeat tickets.

Problematic coax accounts for 40 to 50 percent of all repeat calls. In addition, issues with coax account for more than 90 percent of all problems with video, voice, data, and multiroom DVR installations, which is what technicians spend most of their time troubleshooting. These problems only become more apparent upon adding new services below 45 MHz and above 1 GHz. In fact, most homes have never been tested in the higher MoCA frequency ranges up to 1.65 GHz to ensure support for these services.

Find unknown hidden splitters, amplifiers, and faulty coax.

Technicians spend most of their allocated time reworking coax elements when services are disrupted. Until now, even experienced technicians spent hours trying to identify the root cause of video, voice, data, and multiroom DVR impairments. Limited access to much of the coax network exacerbates the issues, because technicians are left to speculate when determining the cause. The JDSU SmartID probes enable technicians of any skill level to determine which coax legs are connected while finding unexpected hidden splitters and house amplifiers. The SmartID lays out the topology of the subscriber's coax network showing what is really connected to the coax. Showing technicians exactly what is present in the coax eliminates guesswork and leads to efficient problem solving.

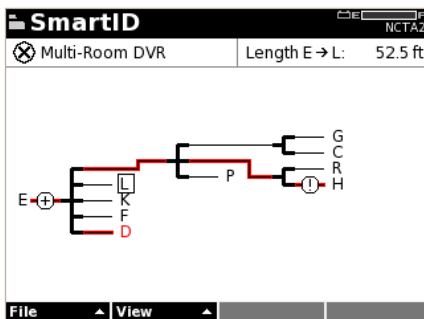

Key Benefits

- Certifies in-home wiring for Triple-Play and MoCA services to avoid repeat visits
- Drastically reduces investigation time and repair associated with inside/in-home wiring
- Protects revenue by lowering risk of customer churn due to repeat fault finding or repairs
- Lowers OpEx by reducing repeat truck rolls

Applications

- Verify inside wiring (quality and topology) and service distribution (WiFi and MoCA)
- Verify the optic-coax handover

JDSU SmartID Advanced Coax Probes

COMMUNICATIONS TEST &
MEASUREMENT SOLUTIONS

Distinguish between Triple-Play and MoCA issues.

Using SmartIDs at each set top box (STB), embedded Multimedia Terminal Adapter (eMTA), and cable modem location enables technicians to verify that each coax path can handle all of the planned services. The SmartID coax probes enable validation of all connected locations from the point of entry to the subscriber's equipment location for Triple-Play services as well as STB-to-STB locations for MoCA services.

Drastically reduce time investigating and repairing by knowing what to fix.

The SmartID system saves time troubleshooting because it gives technicians the location of the impairment. Rather than repeatedly segmenting the network, making a change, then retesting, technicians can now view the impairment location and go directly to it, thus speeding troubleshooting time and reducing the frustration associated with the guesswork of determining the root cause.

Determine salvageability of a faulty drop cable.

Often when technicians determine that a drop cable is faulty, they simply re-run/re-lay it without knowing whether it can be easily fixed. Time and money wasted to re-run, bury, or hang a new drop adds up very quickly. SmartID testing now enables technicians to know whether they can quickly fix the drop or they indeed need to replace it with a new one.

Verify inside/in-home wiring for future Triple-Play and MoCA services.

As recent history shows, subscriber services evolve and technologies, such as DOCSIS® and MoCA, change and bit rates increase; however, the coax they run on remains the same. Focusing on fixing service-impacting physical issues guarantees that the coax can handle it for the operators regardless of existing technology versions. Eliminate sending a technician/installer to turn up every new service. With the SmartID, it lets you verify the home wiring beforehand.

Reduce noise returning on the cable plant.

Finding and fixing coax impairments at the subscribers' premises enables technicians to reduce the amount of noise returning on the hybrid fiber coax (HFC) plant. Combining the DSAM with the easy-to-use SmartID probes results in effective noise reduction.

Cost effective because it is based on existing tools.

The JDSU SmartID system eliminates the need to purchase a completely new and costly platform just for multiroom DVR (MoCA) testing. Used in combination with an existing DSAM, the SmartID probes simply add to the existing set of functionality on the equipment technicians use. Also the probes offer scalability, so more units offer greater visibility of the overall coax network, empowering you to adhere to your test and measurement budget. Finally, increased effectiveness by using the SmartID system while troubleshooting home networks enables technicians to get more jobs done, saving you time and money.

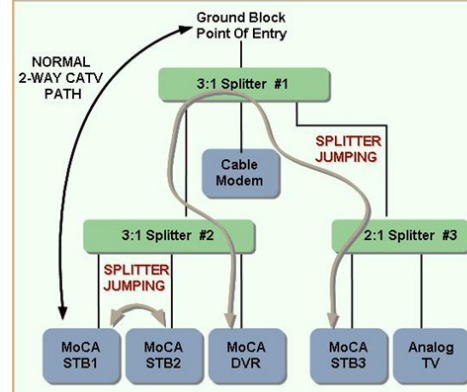
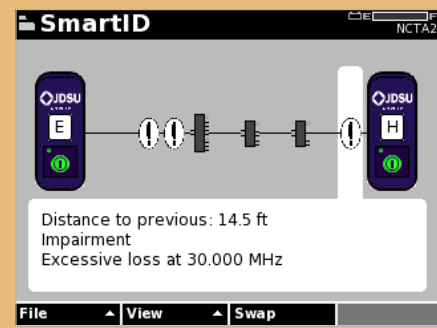
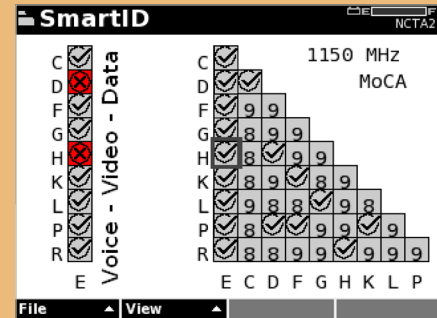

**Minimize the Biggest Time Consumer for Technicians
and Reduce Repeat Tickets!**

Contact your local JDSU Sales Representative for more information.



North America
Tel: 1 866 228 3762
Fax: +1 301 353 9216

Latin America
Tel: +1 954 688 5660
Fax: +1 954 345 4668

Asia Pacific
Tel: +852 2892 0990
Fax: +852 2892 0770

EMEA
Tel: +49 7121 86 2222
Fax: +49 7172 86 1222

www.jdsu.com/test

Product specifications and descriptions in this document subject to change without notice. © 2011 JDS Uniphase Corporation 30168423 000 0611 SMARTID.PS.CAB.TM.AE