

# PoS

Pocket Guide

**Packet over SONET/SDH**



**JDSU**

JDSU is an active member of ITU-T



Publisher: JDSU Eningen GmbH  
Postfach 12 62  
72795 Eningen u.A.  
Germany  
e-mail: [andreas.kaufmann@jdsu.com](mailto:andreas.kaufmann@jdsu.com)  
<http://www.jdsu.com>

Author: Andreas Kaufmann

# Content

Introduction	4
Benefits of Packet over SONET/SDH	7
OSI Model and Internet Protocol	8
Application Layer	9
Transport Layer	11
User Datagram Protocol (UDP)	11
Transmission Control Protocol (TCP)	12
Network Layer – Internet Protocol version 4	15
History of the Internet Protocol	15
Internet Addressing	19
Subnetting	21
Internet Control Message Protocol (ICMP)	22
IP Routing and Switching	23
Packet over SONET/SDH (PoS)	27
Point-to-Point Protocol	28
PPP Encapsulation and PPP Emulation	30
Link Control Protocol (LCP)	31
Network Control Protocol (NCP)	34
High-Level Data Link Control (HDLC)	36
Mapping into the SONET/SDH frame	40
PoS Measurement Tasks	42
Check for PoS Transparency	44
Verify IP Connectivity of new Network Elements	45
Check of PoS Performance	46
Outlook	49
Multi-Service Provisioning Platform (MSPP)	51
Multi-Protocol Label Switching and Multi-Protocol I Switching (MPLS and MPIS)	52
Appendix	54
IP version 6 (IPv6)	54
Terminology	56
Abbreviations	57
References	61

## Introduction

This Pocket guide is intended to provide an overview of transport traffic features and especially the transport below the Internet Protocol (IP) layer, known as Packet over SONET/SDH (PoS).

Towards the end of the 1980s, Synchronous Digital Hierarchy (SDH) and Synchronous Optical Network (SONET) technology were introduced to overcome the problems with Plesiochronous Digital Hierarchy (PDH) technology. Both SDH and SONET are Time Division Multiplexing (TDM) transmission technologies. The SDH/SONET standard has evolved to 10 Gbps for today's new systems, which are mainly optimized for voice transmission. However, the trend is not only towards higher bit rates like 40 Gbps and 80 Gbps, Wavelength Division Multiplexing (WDM) technology is also enjoying steady growth. Systems with up to 160 wavelength channels are now operating, each transmitting 10 Gbps on one fiber.

These trends are driven by market development towards more data oriented traffic as illustrated in Figure 1. IP in particular, continues to grow at an explosive pace. Leading Internet providers report that bandwidth doubles approximately every six to nine months on their backbones.

The adoption of Intranets and Extranets for networked commerce will bring further changes to the IP-service infrastructure, both through bandwidth demands and feature requirements. Service providers recognize this unprecedented explosion in packet-based traffic and are reevaluating their network architectures in light of these changes.

Resourceful designers combine the benefits of Dense Wavelength Division Multiplexing (DWDM), TDM and the reliable SDH/SONET technologies. In doing so it is possible to transport data streams up into the terabit range.

The increased IP traffic requires a technology to transport the IP packets to the physical layer. This transport below IP is presented by Packet over SONET/SDH as one possible route.

figure 1 Trend in traffic types

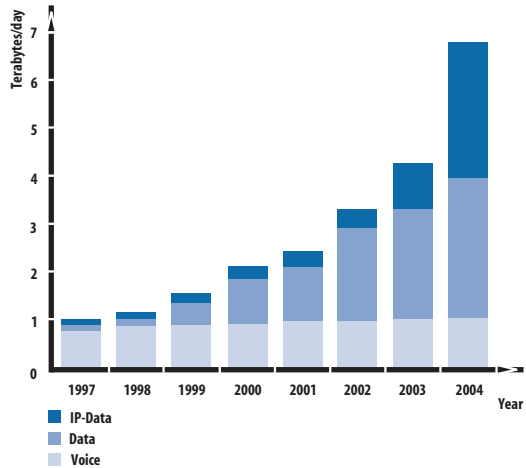

## Benefits of Packet over SONET/SDH

- Efficient point-to-point IP service at high speeds
- Future-proof technology
- IP offers simultaneous handling of voice, video and data traffic
- Utilizes advantages (reliability, scalability and manageability) of existing SDH/SONET infrastructure
- PoS offers significant advantages through efficient bandwidth utilization due to less overhead, see figure 2
- One layer less to manage than with ATM, see figure 3
- Reuse of familiar link-layer protocols

figure 2 PoS and ATM bandwidth efficiency

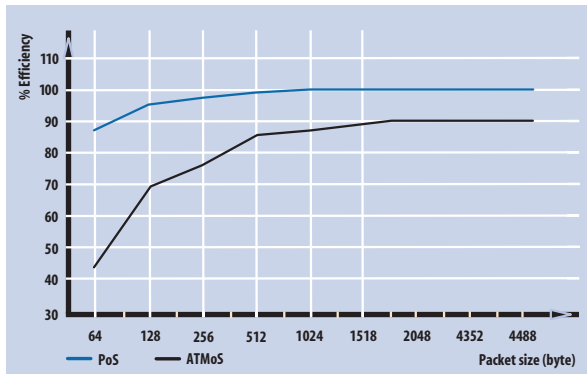
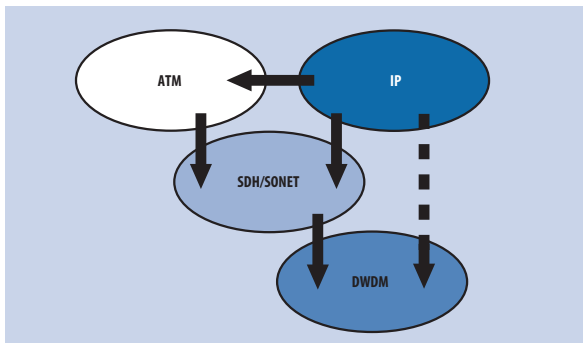

figure 3 Possible scenario for IP traffic to the physical layer



## OSI Model and Internet Protocol

The Open System Interconnection (OSI) model is used to step through a typical transmission process leading to the description of the various layer protocols and finally on to that of Packet over SONET/SDH (PoS) description. As a result, the correlation between the different layers becomes clearer.

figure 4 ISO-OSI model

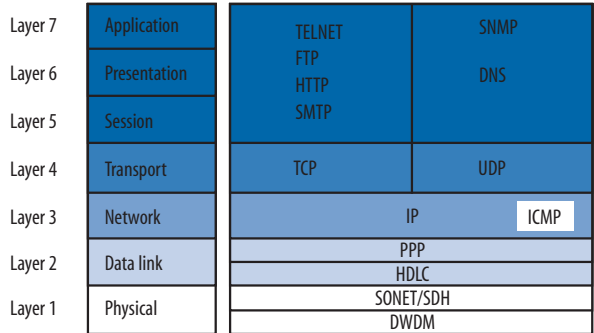

## Application Layer

Figure 4 shows the seven layers of the OSI model. From top to bottom, the OSI model starts with the Application layer which is directly accessible to the user. The signal is then transmitted through several layers to the physical layer.

The Application, Presentation, and Session layers (7, 6 and 5) are merged and in the following section will be referred to as the “Application layer”.

The applications can be divided into two groups, one using the **Transmission Control Protocol (TCP)** for additional transport, the other utilizing **User Datagram Protocol (UDP)** protocol. (The difference between these two protocols will be addressed later.)

Table 1 provides an overview of the most commonly used applications to the reader because they are regularly used in daily life. Some are mentioned briefly below:

<b>User application</b>	<b>Protocol (RFC)</b>	<b>Request For Comments</b>
E-mail	Simple Mail Transfer Protocol <b>SMTP</b>	RFC821
For copying files	File Transfer Protocol	RFC959
File transfer	<b>FTP</b>	
Remote terminal login	<b>Telnet</b>	RFC854
Exchange of WWW information	Hyper Text Transfer Protocol <b>HTTP</b>	RFC1945
For Simple Network Management applications	Simple Network Management Protocol <b>SNMP</b>	RFC1157
Identification of host with IP address	Domain Name System <b>DNS</b>	RFC2929, RFC1591

table 1 Application protocols and their use

Due to the more general nature of this booklet, detailed descriptions of the protocols running in the application layers will not be covered.

## Transport Layer

The Transport layer contains two major protocols – TCP and UDP – distinguishable by their reliability and low transport overhead.

**User Datagram Protocol (UDP)** – The User Datagram Protocol is the simpler of the two and is typically used when reliability and security are of secondary importance to the speed and size of the overhead. It is an end-to-end protocol which adds port addresses, checksum error control and length information to data from the upper layer. Figure 5 illustrates the UDP header format.

figure 5 UDP datagram

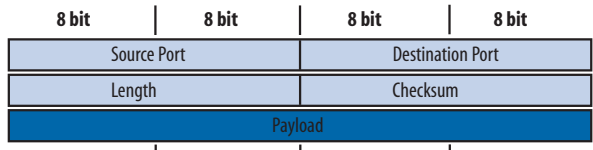

table 2 Definitions of UDP header fields

Table 2 provides a brief description of these header fields:

<b>Source port</b>	Specifies the port address of the application which created the message
<b>Destination port</b>	Specifies the address of the application program which will receive the message
<b>Length (16 bit)</b>	Specifies the total length of the user datagram in bytes
<b>Checksum</b>	This is a 16-bit field used in error detection

When paired with the **Internet Control Message Protocol (ICMP)**, UDP can inform the transmitter when a user datagram has been damaged and discarded. Neither protocol is able to specify which packet has been damaged when repairing an error. UDP can only signal that an error has occurred.

**Transmission Control Protocol (TCP)** – TCP provides full transport layer services to applications. It is **connection-oriented**, meaning that a connection must be established between two peers before either can transmit data. In doing so, TCP establishes a **virtual connection** between sender and receiver which remains active for the duration of the transmission.

Each transmission via TCP starts with a message to the receiver, alerting it that more IP packets are on their way. Each transmission is terminated by a termination message. When sending data, TCP divides long data packets into smaller data units and packages them into “segments.” Each segment includes a sequencing number for reordering after receipt, as well as an acknowledgement ID number. These segments are transported across the network inside the IP datagrams. The receiver collects each datagram as it comes in and re-orders the transmission based on the sequence numbers. TCP is a reliable protocol, as each data transmission is acknowledged by the receiver with TCP, data is transmitted in both directions. If the sender does not receive acknowledgement within a specified time, it retransmits the data.

figure 6 TCP datagram

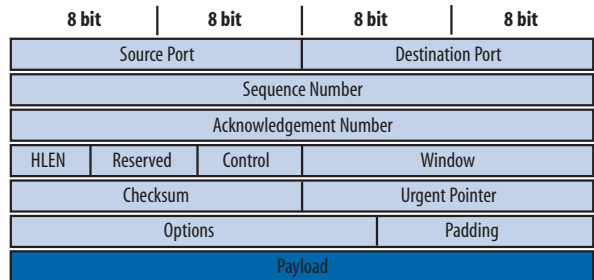

To provide secure delivery for the TCP an extensive segment header is required (see figure 6).

Table 3 contains a description of the TCP segment fields:

table 3 Definitions of TCP header fields

<b>Source port</b>	Defines application program in the source computer.
<b>Destination port</b>	Defines the application program in the destination computer.
<b>Sequence number</b>	The Sequence number shows the position of the data in the original data stream.
<b>Acknowledgement number</b>	32-bit acknowledgement number is used to acknowledge receipt of data.
<b>Header length (HLEN)</b>	Indicates the number of 32-bit words in the TCP header.
<b>Reserved</b>	6-bit field reserved for future use.
<b>Control</b>	6-bit field providing control functions.
<b>Window size</b>	16-bit field defines the size of the sliding window.
<b>Checksum</b>	16-bit checksum used in error detection.
<b>Urgent pointer</b>	Valid only when the URG bit in the control field is active.
<b>Options and padding</b>	Defines optional fields and are used to convey additional information to the receiver or for alignment purposes.

## Network Layer – Internet Protocol version 4

### *Comparison of UDP and TCP protocols*

#### **UDP features include:**

- Connectionless protocol
- No error recovery
- Unreliable
- Fast speed
- Small overhead

#### **TCP features include:**

- Connection-oriented protocol
- Error detection and recovery
- Reliable
- Slower than UDP
- Large overhead

#### **UDP applications include:**

- Voice
- Broadcasting

#### **TCP applications include:**

- HTTP
- FTP

***The History of the Internet Protocol*** – The Internet Protocol (IP) was developed by the Advanced Research Project Agency (ARPA), an arm of the U.S. Department of Defense and was first tested in 1968/69 with computer-to-computer connections. The objective was to ensure that the military could maintain communications in the event of a nuclear war. The protocols and conventions developed by the ARPA evolved to become TCP/IP. Due to the growth of TCP/IP traffic the ARPANET became the backbone of a network known today as the Internet.

figure 7 The format of an IP datagram

IP is the transmission method used by TCP/IP. IP transport is sent in packets called “datagrams”, each of which are transported separately. The individual packets may travel by different routes, as IP has no tracking capabilities or facility for reordering lost datagrams.

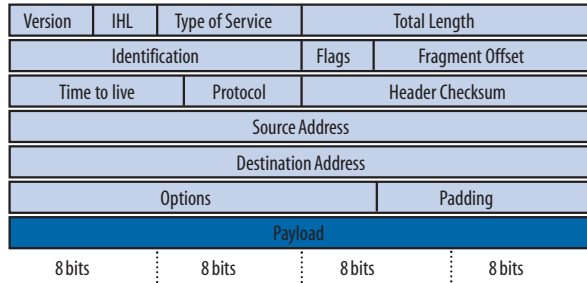

table 4 Definitions of IP header fields

An IP datagram is a variable-length packet of up to 65,536 bytes consisting of two parts; the header (made up of 20 to 60 bytes) and the data (20 to 65,536 bytes). The header contains essential information about routing and delivery service of the IP packets. The structure of the IP header is illustrated in figure 7.

<b>Version</b>	This field defines the version number. IPv4 corresponds to bin. 0100.
<b>Internet Header Length (IHL)</b>	This field defines the length of the header in multiples of four bytes.
<b>Type of Service</b>	This field defines how the datagram should be handled (priority of transport, reliability and delay) and contains information on the Type of Service (ToS).
<b>Total Length</b>	This field defines the total length of the IP datagram. It is a two-byte field (16 bits) and can define up to 65,536 bytes (this includes the header and the data).
<b>Identification</b>	This field is used in fragmentation. When packets are moving independently through the network, they are identified by a number in this field.
<b>Flag</b>	The bits in this field handle fragmentation.
<b>Fragmentation offset</b>	This field provides a pointer which shows the offset of the data in the original datagram.

<b>Time to Live</b>	This field defines the number of hops a packet can travel before it is discarded. The source host sets this field to an initial value (max. 256). Each router decrements this value by "1". Should this value reach "0" before the datagram reaches its destination, it is discarded.
<b>Protocol</b>	This field defines which upper-layer protocol data are encapsulated in the packet (e.g. TCP, UDP, ICMP, etc.).
<b>Header Checksum</b>	Field of 16 bit length, calculates the checksum of the header only.
<b>Source Address</b>	This field contains a four-byte (32-bit) with IPv4 Internet address and identifies the original source of the packets.
<b>Destination Address</b>	This field contains a four-byte (32-bit) with IPv4 Internet address and identifies the final destination of the packets.
<b>Options</b>	This field can carry information which controls the routing, timing, management and alignment of the data.

figure 8 IP address structure

Internet Addressing – The source and destination address identify the connection of the host to its network. Each internet address consists of four bytes (32 bits) which define three fields: class type, Net-ID and Host-ID. These fields have varying lengths depending on the class of the address. The general structure of the IP address is illustrated in figure 8.



Currently five different classes exist from A to E. They each are different pattern lengths and are designed to cover the needs of different types of organization. The Internet classes and their byte distribution are shown in figure 9.

figure 9 Existing Internet address formats

Class	Octet 1	Octet 2	Octet 3	Octet 4
A	0 Net-ID	Host-ID		
B	10 Net-ID	Host-ID		
C	110 Net-ID	Host-ID		
D	1110 Multicast Address			
E	1111 Reserved for future use			

table 5 Internet Class addresses and their potential use

**Class A** only uses one byte to identify the class type and Net-ID, leaving three bytes available for Host-ID numbers. This results in Class A networks accommodating far more hosts than **Class B** or **C** networks. At present Classes A and B are full. Addresses are only available in Class C.

An overview of how many networks and hosts can be supplied by different types of class is shown in table 5.

<b>Class A</b>	– 127 possible network IDs – 16,777,214 host IDs per network ID
<b>Class B</b>	– 16,384 possible network IDs – 65,534 host IDs per network ID
<b>Class C</b>	– 2,097,152 possible network IDs – 254 host IDs per network ID

**Class D** is reserved for **multicast** addresses. This means that IP datagrams are allowed to be delivered to a selected group of hosts only, rather than to an individual.

**Class E** is reserved for future use. Internet addresses are usually written in decimal form, points separating the bytes (for example 137.23.145.23).

figure 10 IP addressing in case of subnetting

Subnetting – To circumvent some of the limitations of the addressing conventions of IPv4, it is possible to introduce subnet structures. The addressing convention (RFC950) used results in the following division of the classes (see figure 10).



The network administrator is able to divide the host address space into groups (subnets) mainly to mirror topological or organizational structures. At a university, for example, the various faculties might be groups under the host name. This procedure simplifies routing in a network and allows a clearer structure of the network to be seen. Figure 11 illustrates how a subnetting structure might look.

figure 11 Example of subnetting for a Class A type IP address.

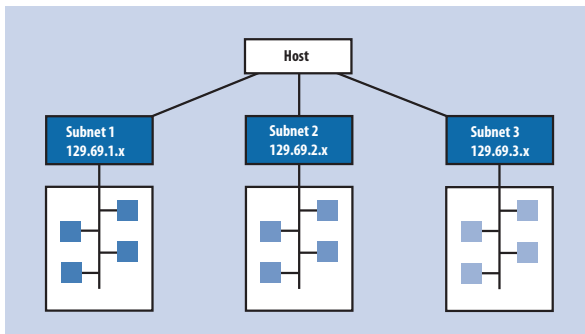

**Internet Control Message Protocol (ICMP)** – The Internet Control Message Protocol (ICMP) is used by hosts and gateways to inform the sender of datagram problems and to exchange control messages. The Internet Control Message Protocol (Recommendation RFC792) uses IP to deliver these messages. Although IP is an unreliable and connectionless protocol, ICMP uses IP to inform the sender if a datagram is undeliverable. ICMP only reports problems, it does not correct errors. The following examples show the types of messages which could be sent:

**Error messages:**

- Destination unreachable
- Redirect packet
- Time exceeded

**Information messages:**

- Echo request, echo response
- Time stamp (Ping)

If a user were to type an incorrect HTTP address in the Web browser, it would be sent to the DNS server which in turn would return an IP address to be sent to the respective server. If the server were down, the message “Destination unreachable” would be sent to the user.

***IP Routing and Switching*** – In the Internet, packets are dynamically routed from the source to the destination by a hop-by-hop movement. Routers and switches are used to ensure the packet is delivered correctly.

**Routers** are “intelligent” network elements operating in the Network layer of the OSI model. Routers have access to Network layer addresses and contain software enabling them to determine which of several possible paths between addresses is appropriate for a particular transmission. Routers relay packets among multiple interconnected networks and can route packets from one network to any number of destination networks on an internet (see figure 12).

figure 12 Possible routing scenario

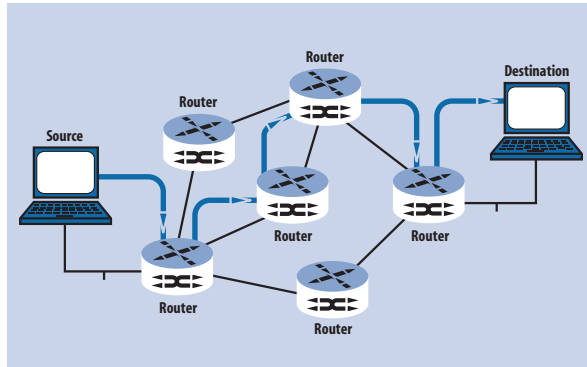

The IP networks are usually designed in a mesh structure so that if an interruption in the transmission occurs, an alternative path can be found quickly. The routing process is a **dynamic procedure** which allows the system to forward a packet via its most efficient path from source to destination address. The “decision” as to how packets are routed through a network follows multiple routing algorithms. The description of these algorithms would, however, be beyond the scope of this booklet.

**Switches** are layer 2 network elements responsible for establishing temporary **static connections** between two or more devices linked to the switch, but not to each other.

figure 13 Switched network

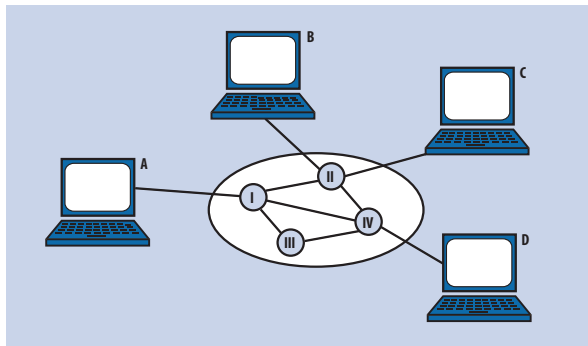
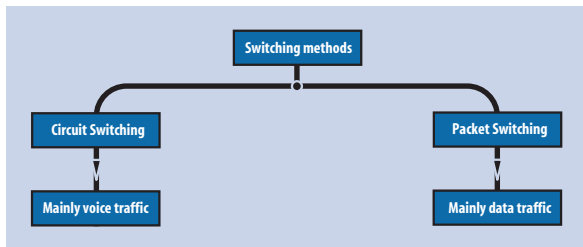

Figure 13 illustrates a switched network. The communicating devices are labeled A, B, C, D, the switches I, II, III, IV. Each switch is connected to multiple links and is used to complete the connections between the communicating peers. As soon as the switches are set, they are static for one specific transmission process and can then be reconfigured. Figure 14 shows two principal switching methods available.

figure 14 Network switching methods



**Circuit switching** was designed primarily for voice communication. In a telephone conversation for example, once a circuit is established it remains connected for the duration of the session. Circuit switching is not suitable for data or other non-conversational transmissions. Non-voice transmissions tend to come in bursts therefore in a circuit switched circuit, the line is often idle and its facilities wasted. In a **packet switched** network, data is transmitted in discrete units of potentially variable length packets. The maximum length of a packet is established by the network and long transmissions are broken into multiple packets. Each packet contains not only the data but also a header containing the control information. The packets are sent over the network hop-by-hop and routed through the network according to the information in the packet header with the address information. With **Message switching**, a network node receives a message, stores it until the appropriate route is free, then sends it.

## Packet over SONET/SDH (PoS)

figure 15 Alternative routes for transmitting IP packets to the fiber

From the Network layer, the IP packets need to be delivered to underlying layers. The actual transmission below the Transport layer is called Packet over SONET/SDH (PoS). This transmission can be achieved via alternative routes, two of which are illustrated in figure 15.

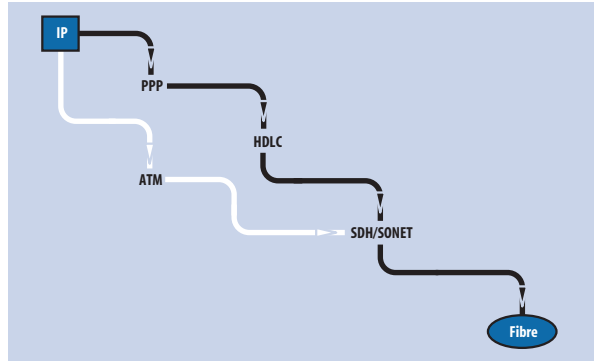

The route (black line) described in this booklet is recommended by the Internet Engineering Task Force (IETF) and is illustrated in figure 16.

figure 16 Mapping of IP packets into SONET/SDH frames

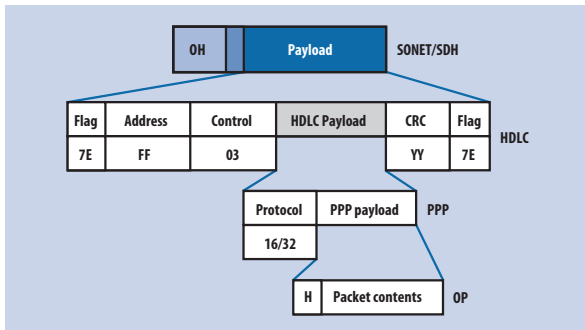

## Point-to-Point Protocol

The IP packets are encapsulated in a Point-to-Point Protocol which in turn is mapped into a HDLC-like frame. This frame is then mapped into the SONET/SDH frame.

The Point-to-Point Protocol (PPP) provides a standard method for transporting multi-protocol datagrams (e.g. IP packets) over point-to-point links. Initially, PPP was used over Plain Old Telephone Services (POTS). However, since the SONET/SDH technology is by definition a point-to-point circuit, PPP/HDLC is well suited for use over these lines. PPP is designed to transport packets between two peers across a simple link.

**Features of the PPP link:**

- Allows for full-duplex and simultaneous operation
- No restrictions regarding transmission rates imposed
- Operates across most Data Terminating Equipment/Data Circuit-terminating Equipment (DTE/DCE) interfaces (e.g. RS232, RS422, V.35, etc.)
- Does not require any hardware control signals (e.g. Request to Send, Clear To Send, etc.)

PPP is intended to provide a common solution for the easy connection of a wide variety of hosts, bridges and routers. The encapsulation of PPP into HDLC-like frames allows for the multiplexing of different network-layer protocols (IP, IPX, AppleTalk, etc.) simultaneously over the same link.

**PPP consists of three main components:**

- A method for encapsulating multi-protocol datagrams (PPP encapsulation)
- A Link Control Protocol (LCP) for establishing, configuring and testing of the data link connection
- A family of Network Control Protocols (NCPs) for establishing and configuring different network layer protocols

## PPP Encapsulation and PPP Emulation

**PPP Encapsulation** – To allow multi-protocol datagrams to be transmitted across a link, a method must be used to enable unambiguous decisions to be made between the various protocols. The PPP encapsulation of the IP packets is illustrated in figure 17.



figure 17 PPP encapsulation according to RFC1661

The fields are transmitted from left to right and have the following names and functions:

**Protocol Field** – Consists of 1 or 2 octets, with values identifying the encapsulated datagram.

**Data Field** – This field is zero or more octets long and it contains the datagram for the protocol specified in the Protocol field. The maximum length, including padding (but not the protocol field) defaults to 1500 octets. This means, for example, that if an IP datagram with a larger payload were transported it would be fragmented into several packets to fit the size of the data field.

**Padding Field** – At the beginning of the transmission this field may be padded with an arbitrary number of octets (up to 1500 octets). It is the responsibility of the protocol to distinguish padding from real information.

## Link Control Protocol (LCP)

figure 18 Illustration of LCP procedure

**PPP Emulation** – The **PPP emulation** describes:

- The Link Control Protocol and
- The Network Control Protocol

The LCP is responsible for correctly establishing, configuring and testing the Point-to-Point Protocol. Before IP datagrams can be transported across a PPP link, each of the connected PPP interfaces must send out a series of LCP packets.

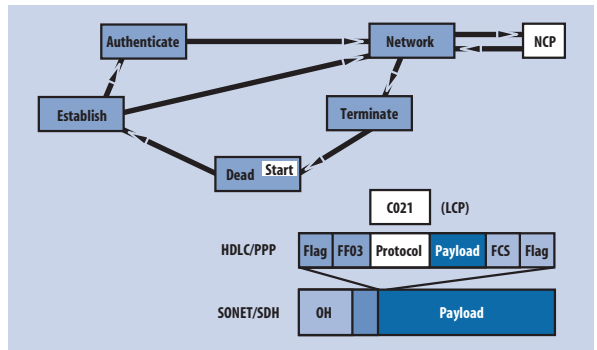

Figure 18 illustrates the four key phases the LCP steps through.

**Step: Link dead** – Each PPP connection starts and ends in this state. In this state there is either no connection to the modem or the connection has been interrupted. When an external event (control signal or network administrator) indicates that the Physical layer is ready to be used, PPP proceeds to the establishment phase.

**Step: Link Establishment** – Before data from an upper layer (e.g. IP) can be transported across a connection, the link is prepared via configuration packets. This exchange is completed, and the Open state achieved after a “Configure” packet has been sent and received. The entire configuration options are set to default values, unless altered. Any non-LCP packets received during the establishment phase are discarded.

**Step: Authentication** – This is an optional step, allowing the PPP peers to identify each other via authentication protocols. These are called **Password Authentication Protocol (PAP)** and **Challenge Handshake Authentication Protocol (CHAP)**.

The **Password Authentication Protocol** sends a password across the link, so that the circumstances in which it can operate are negotiated.

The **Challenge Handshake Authentication Protocol** has the ability to provide reliable and secure authentication. As the authenticator and authenticatee share a common password. The authenticator sends the connected peer a challenge in the form of a random number. The authenticatee uses this random number to derive a secret code. This code is then transmitted to the authenticator and if the results match, the next connection stage can proceed.

**Step: Network Layer Protocol Configuration** – This is necessary for the configuration of the Network Control Protocols (NCP) used on this connection. Each network layer protocol (e.g. IP, Appletalk, etc.) must be separately configured by the appropriate NCP. It is possible with PPP to run several NCPs over one connection.

After an NCP has reached the Opened state, PPP will carry the corresponding network layer protocol packets. Any network layer protocol packets received when the corresponding Opened state has not been reached are discarded. During this phase, link traffic consists of any possible combination of LCP, NCP and network layer protocol packets.

**Step: Link Termination** – With the LCP it is possible to close a connection at any time. This can be done by a user event, set timer or missing interface signal. Between step 3 and step 4, Link Quality Monitoring (LQM) can take place and the data connection tested for quality of transmission. The **Link Control Protocol information** is sent in the form of PPP datagrams, which fall into the following three major classes:

- **Link Configuration packets** used to establish and configure a link (RFC1661)
- **Link Termination packets** used to terminate a link (RFC1661)
- **Link Maintenance packets** used to manage and debug a link (RFC1661)

## Network Control Protocol (NCP)

A family of Network Control Protocols allow for the preparation and configuration of different protocols to run in the various network layers. One of these protocols, the IPCP, is described below as an example and is illustrated in figure 19.

figure 19 Illustration of a common NCP procedure

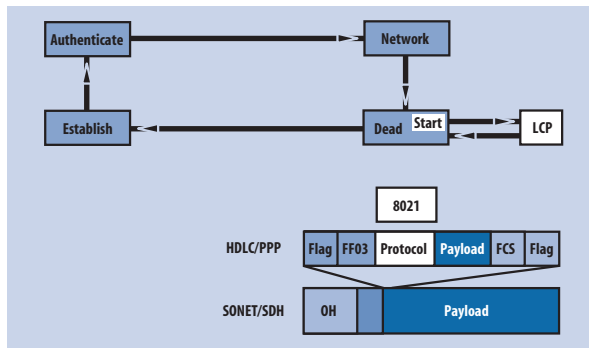

This protocol allows for the activation, configuration and deactivation of the IP protocol modules on both sides of the point-to-point connection. Like the LCP, these functions are achieved through the exchange of special data packets, for IPCP, this packet is hex 8021 (protocol identifier). The exchange of IPCP packets starts after completion of step 4 of the LCP protocols. The NCP then runs through steps equivalent to those of the LCP procedure once the LCP protocol is in the network state (see figure 21).

## High-Level Data Link Control (HDLC)

figure 20 Format of HDLC-like frame according to RFC1662

When the LCP and the NCP protocols are fulfilled the data can be transmitted across the point-to-point connection.

The Point-to-Point Protocol provides a standard method for transporting multi-protocol datagrams over point-to-point links. The PPP packets are encapsulated in a HDLC-like frame which is then mapped into the SONET frame. The format of this HDLC frame is illustrated in figure 20.



**Flag Sequence** – Each frame begins and ends with a Flag Sequence, which is the binary sequence 01111110 (hex 0x7e). All implementations check for this flag which is used for frame synchronization. Only one Flag Sequence is required between two frames. Two consecutive Flag Sequences constitute an empty frame which is then discarded silently.

**Address Field** – The Address Field is a single octet containing the binary sequence 11111111 (hex 0xff). Individual station addresses are not assigned.

table 6 Identifiers used in the protocol field in the HDLC frame

**Control Field** – The Control Field contains the binary sequence 00000011 (hex 0x03). Frames with unrecognized Control field values are discarded silently.

**Protocol Field** – The Protocol Field is one or two octets, with a value identifying the datagram encapsulated within the Information field of the packet.

The identifiers for the most frequently used protocols are:

Hex value	Protocol used
0021	IP
C021	LCP
8021	NCP (IPCP)

**Information** – The Information field is zero or more octets and contains the datagram for the protocol specified in the Protocol field. The Information field, including Padding but not including the Protocol field, is called the Maximum Receive Unit (MRU) and has a maximum length of 1500 octets.

**Padding** – The Information field may be padded with an arbitrary number of octets up to the MRU.

**Frame Check Sequence Field** – The Frame Check Sequence (FCS) defaults to 16 bits for OC-3/STM-1 although other speeds use 32 bits as well. Its use is described in PPP LCP Extensions of RFC2615.

The FCS field is calculated over all bits of the Address, Control, Protocol, Information and Padding fields and is illustrated by the grey fields in figure 21. It **does not include** the Flag Sequences or the FCS field itself.

figure 21 Fields of the HDLC-like frame used to perform the FCS



PPP uses the FCS for error detection and is commonly available in hardware implementations. The end of the Information and Padding fields is found by locating the closing Flag Sequence and removing the Frame Check Sequence field. The **HDLC process** and related recommendations are illustrated in figure 22.

figure 22 How an IP packet is transmitted to and received by the SONET/SDH frame

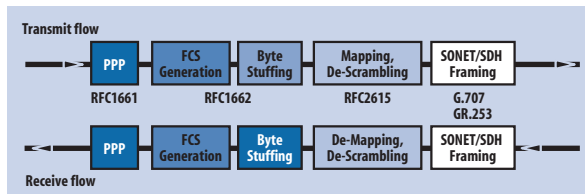

**FCS generation/detection** – See page 38.

**Byte stuffing/destuffing** – The PPP protocol **must not** place any restrictions on the use of certain bit patterns in the network layer packet and must be **transparent** to any type of data. Because the PPP protocol uses specific patterns, e.g. the flag **field 0x7e** which indicates the beginning and end of a frame, a method is required to avoid restrictions. This is achieved through **byte stuffing** where the PPP defines a special **control escape byte, 0x7d**. The byte stuffing procedure also acts for the Control Field and the Control Escape byte.

The process of byte stuffing is illustrated in Figure 23 where the Flag 7E is replaced by 7D,5E.

figure 23 Illustration of the Byte stuffing procedure

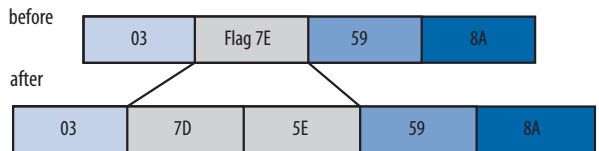

If the Control Flag 7D is within the payload, it is replaced by 7D,5D.

**Scrambling/Descrambling procedure** – Described in RFC2615, a data scrambler with the  $1+x^43$  polynomial is used in this procedure. While the HDLC FCS is calculated, the scrambler operates continuously through the bytes of the payload bypassing SONET Path Overhead bytes and any fixed information. This type of scrambling is performed during insertion into the SONET/SDH payload.

The **Path Signal Label C2** is used so that the SONET/SDH can recognize the payload content.

table 7 Path Signal label  
C2 identifier

Value signal label C2	Scrambler state
0x16	PPP with $1+x^{43}$ scrambling
0xCF	PPP with scrambler off

## Mapping into the SONET/SDH frame

The PPP frames are inserted into the SONET/SDH payload sequentially row by row and sit in the payload envelope as octet streams aligned to octet boundaries.

figure 24 Mapping of HDLC/PPP/IP packets into the SONET/SDH payload

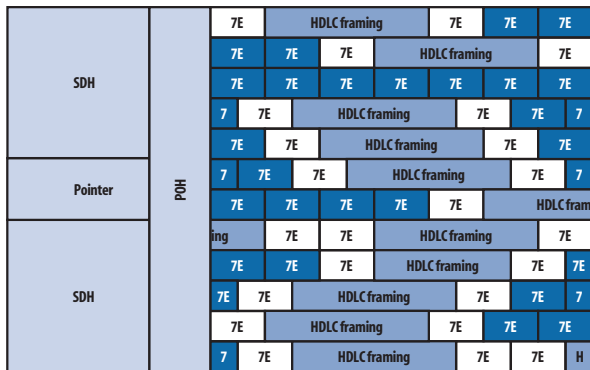

Because the frames can be of variable length they are allowed to cross the SONET/SDH boundaries. The HDLC frames are mapped into the SONET/SDH frame dynamically meaning that when there is no traffic, the SONET/SDH frame is filled with **idle frames** 7E, see figure 24.

## PoS Measurement Tasks

With the increase in IP traffic transported across SDH/SONET/DWDM networks, it is necessary to measure the quality parameters with genuine IP traffic. Thus, the payload is filled with HDLC/PPP/IP packets instead of a traditional Pseudo Random Bit Sequence (PRBS). This corresponds to a more realistic representation of the real traffic to be transmitted on these networks.

The user is provided with information on how many packets were lost in a specified period (for example 24 hours), instead of an error rate of 10<sup>-14</sup> for instance. This is more informative than the traditional error rate when sending packets.

Using packets instead of PRBS to fill the payload provides a more realistic traffic profile. Due to the increased transport data and IP traffic in our networks, the payload being filled with IP packets will become more widely accepted in the future.

The following applications are suitable for measuring the quality parameters of individual Network Elements (NE) as well as entire SDH/SONET/DWDM networks during installation.

**Frame errors** – This error message gives information on the number of HDLC frames lost over a predefined period of time. The customers benefit from receiving a performance measurement based on packet and not byte parameters.

**Frame rate** – This is the rate of frames which are sent over the link and are calculated from the HDLC frame size and the bandwidth.

**Transfer delay** – The transfer delay is the amount of time it takes for IP packets to travel a set path through the network.

**HDLC bandwidth** – This corresponds with the user set bandwidth of the link. The allowable bandwidth depends on the interface used and the container size chosen.

**HDLC utilization** – This is a percentage measure of how much of the link is actually in use. These parameters are usually measured by the following applications:

- Transparency testing
- Connectivity testing and
- Performance testing

## Check for PoS Transparency

This measurement is mainly performed by carriers and fiber installers. It is needed to qualify the line for data transport, thereby guaranteeing that the transmission between two points (A and B) does not exhibit any errors. A typical setup is illustrated in figure 25.

It is also possible to send and receive using the same instrument (see figure 25, dotted line) so that a specific line segment can be tested for transparency.

figure 25 Typical setup for a transparency check

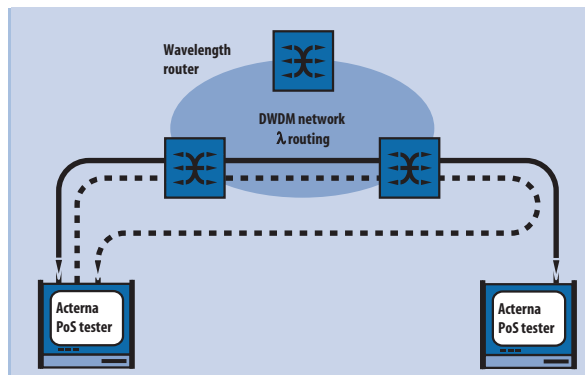

## **Verify IP Connectivity of new Network Elements**

To guarantee the proper setup of the transmission line, the measuring equipment sends HCLC/PPP/IP frames and receives them again when the transmitter and the receiver are looped back to each other.

The parameters which can change are the frame size (in bytes) and the bandwidth of the transmission. It is also possible to introduce errors and check the resulting degradations on the receiver. The result of this measurement provides the following parameters: frame error, frame rate, transfer delay, link bandwidth and link utilization.

Usually, this test is performed when a new NE or a new user is connected to the network. It checks whether the NE or user is properly connected to the network and if it is able to communicate. A typical test setup is shown in figure 26.

The test equipment sends out a “ping” and waits for the response. Thus measuring the round trip delay of the “ping”. The “ping” parameter provides definite information about the state of connection of the NE and the time delay indicates if the line to and from the NE is OK. The customer benefits by receiving information about the connection of a new NE.

figure 26 Typical measurement arrangement to check connectivity of NE

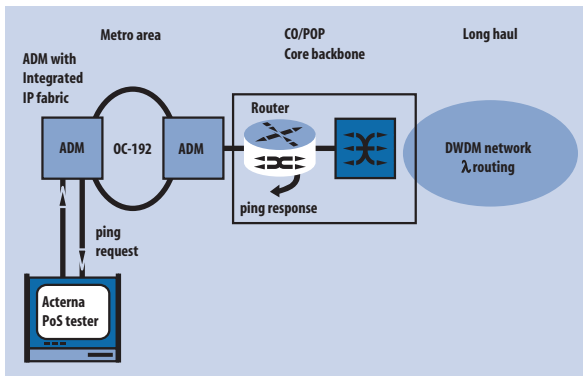

### Check of PoS Performance

This is a test of particular Network Elements and the entire network under load and checks the interfaces of Network Elements.

Figure 27 illustrates a typical arrangement for such a measurement test.

figure 27 Measurement arrangement to check performance of PoS Network Elements

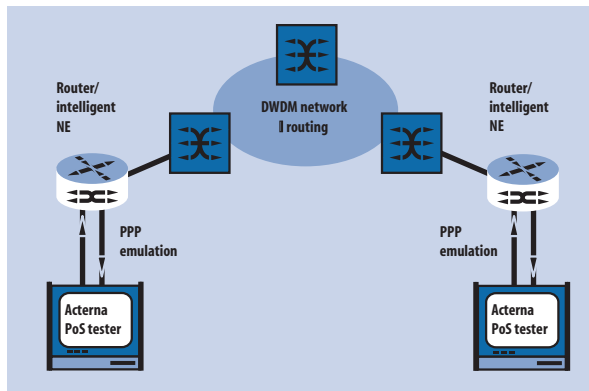

This test is performed when the customer is connected to the network or when new connections between NEs are installed. The measuring instrument sends a signal and checks if the NE is connected and can pass the signals through to the next network element. To perform the PoS performance test, the equipment must be capable of performing the entire PPP emulation. This measurement delivers the same parameters as the transparency check.

### Summary of applications

table 8 Summary of possible applications for PoS systems

	<b>Challenge</b>	<b>Solution</b>	<b>Parameters</b>
<b>PoS Transparency</b>	Is the line between two users properly set up and transparent for IP traffic?	Send IP traffic and check the return traffic.	Frame error, frame rate etc.
<b>Connectivity</b>	Is a NE or user properly connected to the network?	Send ping request and wait for answers from NE or user. A full PPP emulation is required.	Ping and delay time.
<b>PoS Performance</b>	How does the system behave under stress?	Perform test under load with full PPP emulation.	Frame error, frame rate etc.

## Outlook

Future networks will need to cope with the ever-increasing bandwidth requirements mentioned in the introduction of this booklet.

TDM transmission rates are increasing to 40 Gbps while simultaneously the number of channels in DWDM systems are increasing to 128 and more. Total capacity rates of approximately 320 Gbps, 1 Tbps and higher are therefore quite possible. This challenge will be met by some of the technologies described in the following pages.

When discussing possible future networks the expression **converging networks** is often used.

figure 28 Possible convergence scenario in the telecommunication world

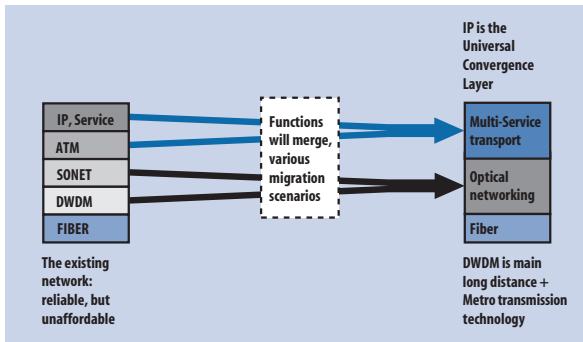

Converging networks lead to a decrease in the number of network elements and potentially less trouble for network operators. One platform used in this process is the so called Multi-Service Provision Platform. In addition, techniques like Multi-Protocol Label Switching and Multi-Protocol  $\lambda$  Switching will help to establish this trend. Figure 28 illustrates the possible convergence of functions with various layers.

## **Multi-Service Provisioning Platform (MSPP)**

Since the majority of new telecommunication services are data-oriented, the transmission on these networks should be “data optimized”. This is achieved with Multi-Service Provisioning Platforms (MSPP) which allow for the aggregation and switching of data packets by one network element.

MSPPs can switch voice and video as well as different types of data traffic. The following three main features are necessary to perform the above tasks:

- Use DWDM technology to increase capacity of fibers
- Use of SONET/SDH to ensure QoS for time sensitive applications
- Use of layer 2 and layer 3 data intelligence (switches and routers) thus allowing products to switch and route data traffic

Combining these features into one instrument enables service providers to simplify their networks. Instead of installing a DWDM multiplexer, ADM and an IP router, just one device can be used. The number of devices and potential problems are reduced as a result.

## **Multi-Protocol Label Switching and Multi-Protocol I Switching (MPLS and MPIS)**

Multi-Protocol Label Switching (MPLS) is a high performance method of forwarding packets through a network. It is used by routers at the edge of the network to apply simple labels (or identifiers) to packets. These labels allow routers to switch packets according to their label with a minimal lookup overhead.

MPLS integrates the performance and traffic management capabilities of layer 2 with the scalability and flexibility of layer 3.

The label summarizes essential information about routing the packet including:

- Destination of packet
- Precedence of packet
- QoS information
- The route for the packet, as chosen by Traffic Engineering (TE)

At each router throughout the network, only the label of the incoming packet need be examined in order for it to be sent on to the next router across the network.

Advantages of this are that only one table lookup list from a fixed length label is required and switching and routing functions can be combined. As with a router, an Optical Cross Connect (OXC), can intelligently route a wavelength through an OXC. The so called Multi-Protocol I Switching signaling allows an OXC to convey a signal to

the next OXC. These devices exhibit similar advantages to the MPLS, by reducing the number of elements and potential problems in the network.

# Appendix

## IP version 6 (IPv6)

With the increasing number of Internet users, the pool of available addresses defined by IPv4 is decreasing fast. IP version 6 (IPv6) is addressing this and several other issues such as:

Quality of Service (QoS). The header is simpler and more flexible than for IPv4 due to the optional extension header. IP version 6 has already been standardized and test trials are running. It is still not widely used yet despite the fact that many large routers have already implemented IPv6. IPv6 is 128 bits long and consists of 16 bytes (octets). The protocol specifies hexadecimal colon notation. Whereby 128 bits are divided into eight sections, each of which are two bytes in length. An example of a principal IPv6 address appears in figure 29.

figure 29 Possible IP address with IPv6



```
FEEA:7648:CD33:9854:7654:FEDC:CE3E:0020
```

As with IPv4, the IP datagram for IPv6 consists of a mandatory base header followed by the payload. The payload consists of two parts: an optional extension header and data from an upper layer (see figure 30).

figure 30 IP header for IPv6

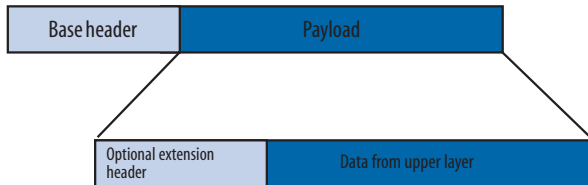

Changes in the way IP header options are encoded enable more efficient forwarding, less stringent limits on the length of options and greater flexibility in introducing new options.

A new capability has been added to facilitate the labeling of packets belonging to a particular traffic "flow" for which the sender must request special handling. The simpler header offers faster processing by routers.

## Terminology

The following definitions are taken from RFC recommendations.

**Frame** – The unit of transmission at the data link layer. A frame may include a header and/or a trailer, along with some number of units of data.

**Packets** – The basic unit of encapsulation, which is passed across the interface between the network layer and the data link layer. A packet is usually mapped to a frame; the exceptions are when data link layer fragmentation is being performed, or when multiple packets are incorporated into a single frame.

**Datagram** – The unit of transmission in the network layer (such as IP). A datagram may be encapsulated in one or more packets passed to the data link layer.

**Peer** – The other end of the point-to-point link.

**Silently discarded** – The implementation discards the packet without further processing. The implementation should provide the capability of logging the error, including the contents of the silently discarded packet, and should record the event in a statistics counter.

## Abbreviations

### A

ADM Add-Drop Multiplexer

ARPA Advanced Research Project Agency

ATM Asynchronous Transfer Mode

### C

CHAP Challenge Handshake Authentication Protocol

CLEC Competitive Local Exchange Carrier

### D

DCE Data Circuit-terminating Equipment

DNS Domain Name System

DTE Data Terminating Equipment

DWDM Dense Wavelength Division Multiplexing

### F

FCS Frame Check Sequence

FTP File Transfer Protocol

### H

HDLC High-Level Data Link Control

HTTP HyperText Transfer Protocol

## **I**

ICMP Internet Control Message Protocol

IP Internetwork Protocol

## **L**

LCP Link Control Protocol

LQM Link Quality Monitoring

## **M**

MPLS Multi-Protocol Label Switching

MPIS Multi-Protocol I Switching

MSPP Multi-Service Provisioning Platform

## **N**

NCP Network Control Protocol

NE Network Element

## **O**

OSI Open System Interconnection

OXC Optical Cross Connect

## **P**

PAP Password Authentication Protocol

PDH Plesiochronous Digital Hierarchy

PoS Packet over Sonet/SDH

PPP Point-to-Point Protocol

## **R**

RFC 'Request for Comment' documents, used to develop standards, procedures and specifications for TCP/IP, under the control of IETF

## **S**

SDH Synchronous Digital Hierarchy

SONET Synchronous Optical Network

SMTP Simple Mail Transfer Protocol

SNMP Simple Network Management Protocol

## **T**

TCP Transfer Control Protocol

TDM Time Division Multiplexing

TE Traffic Engineering

ToS Type of Service

**U**

UDP User Datagram Protocol

**W**

WDM Wavelength Division Multiplexing

## References

RFC	1662	PPP in HDLC-like Framing
RFC	2615	PPP over SONET/SDH
RFC	1661	Point-to-Point Protocol (PPP)
RFC	950	Internet Standard Subnetting Procedure
RFC	821	Simple Mail Transfer Protocol
RFC	959	File Transfer Protocol (FTP)
RFC	854	Telnet Protocol Specification
RFC	1945	Hypertext Transfer Protocol – HTTP/1.0
RFC	1157	Simple Network Management Protocol (SNMP)
RFC	2929	Domain Name System (DNS) IANA Considerations
RFC	1332	PPP Internet Protocol Control Protocol (IPCP)
RFC	1333	PPP Link Quality Monitoring
RFC	2153	PPP Vendor Extensions
RFC	791	Internet Protocol
RFC	792	Internet Control Message Protocol
RFC	793	Transmission Control Protocol
G.707		Network Node Interface for the synchronous digital hierarchy (SDH)
GR.253		SONET Transport system: Common Generic Criteria

## Notes

All statements, technical information and recommendations related to the products herein are based upon information believed to be reliable or accurate. However, the accuracy or completeness thereof is not guaranteed, and no responsibility is assumed for any inaccuracies. The user assumes all risks and liability whatsoever in connection with the use of a product or its application. JDSU reserves the right to change at any time without notice the design, specifications, function, fit or form of its products described herein, including withdrawal at any time of a product offered for sale herein. JDSU makes no representations that the products herein are free from any intellectual property claims of others. Please contact JDSU for more information. JDSU and the JDSU logo are trademarks of JDS Uniphase Corporation. Other trademarks are the property of their respective holders. ©2005 JDS Uniphase Corporation. All rights reserved.

## Test & Measurement Regional Sales

10143226 500 1005 POS.PG.OPT.TM.AE

### North America

Toll Free: 1 866 228 3762

Tel: +1 301 353 1560 x 2850

Fax: +1 301 353 9216

### Latin America

Tel: +55 11 5503 3800

Fax: +55 11 5505 1598

### Asia Pacific

Tel: +852 2892 0990

Fax: +852 2892 0770

### EMEA

Tel.: +49 7121 86 2222

Fax: +49 7121 86 1222

[www.jdsu.com](http://www.jdsu.com)