

Testing Polarization Mode Dispersion in the Field

Introduction

Competitive market pressures demand that service providers continuously upgrade and maintain their networks to ensure they are able to deliver higher speed, higher quality applications and services to the customers. This requires verifying and ensuring that the network's fiber infrastructure and equipment can meet exacting performance standards and operate reliably. Due to the increased transmission speed and implementation of DWDM systems, some important changes were made in the optical fiber characterization and system turn-up, requiring new test tools and procedures, described in different JDSU white papers.

Polarization Mode Dispersion (PMD) testing is becoming essential in the fiber characterization process, but still one of the most difficult parameter to test, due to its sensitivity to a number of environmental constraints.

Polarization Mode Dispersion Defined

PMD (Polarization Mode Dispersion) is the differential arrival time of the different polarization components of an input light pulse, transmitted by an optical fiber. This light pulse can always be decomposed into pairs of orthogonal polarization modes. These polarization modes propagate at different speeds according to a slow and fast axis induced by the birefringence of the fiber.

Bi-refringence

Optical fibers are slightly birefringent. Birefringence is a default of material (e.g. optical fiber) where the effective index of refraction varies with the polarization state of the input light.

The main causes of this bi-refringence are non-perfect concentricity and in homogeneity of the optical fiber in manufacturing design, as well as external stresses applied on the fiber cabling, such as bends, or twist.

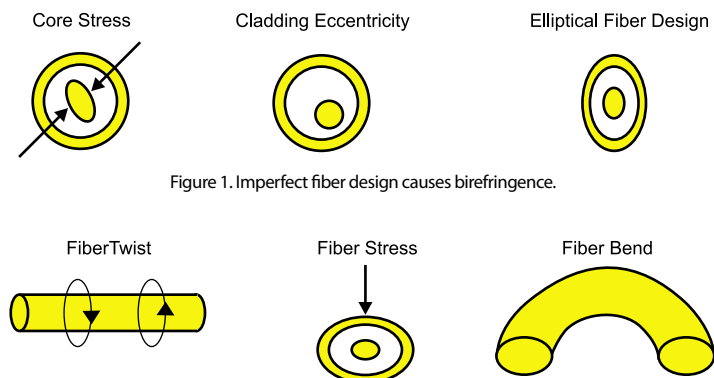

Figure 1. Imperfect fiber design causes birefringence.

Figure 2. External stress causes birefringence.

Differential Group Delay

In a single mode fiber, light is guided through the whole core and in a part of the cladding (referring to Mode field diameter), so that there is only a single propagation mode. However, due to birefringence, the propagation mode is degenerated into two orthogonal modes, defining the two Principal States of Polarization (PSPs). These two PSPs travel at different speeds.

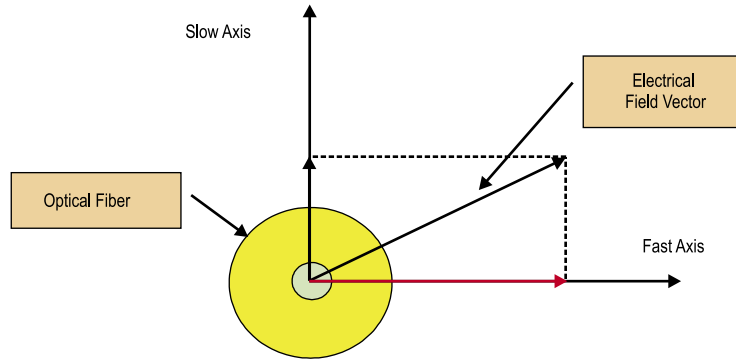

Figure 3: The electrical field vector is decomposed into two polarization modes (fast and slow).

The arrival time difference at the output of the media (fiber) is called the Differential Group Delay (DGD) [$\Delta\tau$ (ps)].

A light pulse transmitted through a “uniform,” Highly Birefringent (HiBi) or polarization maintaining fiber could be defined as the decomposition of the pulse into 2 orthogonal pulses (see figure 1) travelling at different, but constant speed.

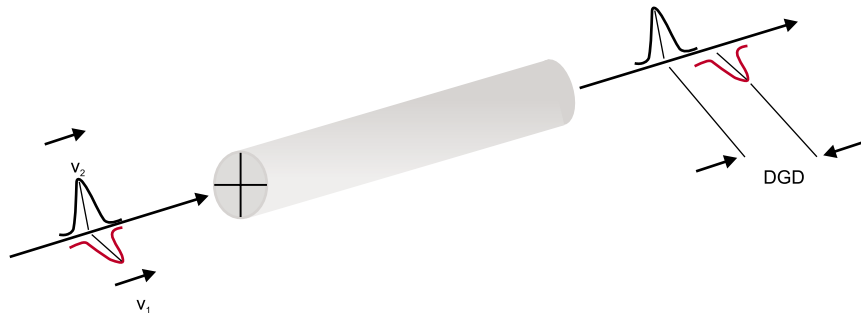

Figure 4. Differential group delay in HiBi fiber.

However, in telecommunication optical fibers, birefringence levels and principal axis are not uniform over the total link, and could be considered as the result of HiBi fibers randomly coupled together.. As a consequence, there is a polarization mode coupling between the fast and slow local PSPs.. This is called a strong mode coupling. Nevertheless, the fiber still exhibits two PSPs and a DGD at one given wavelength.

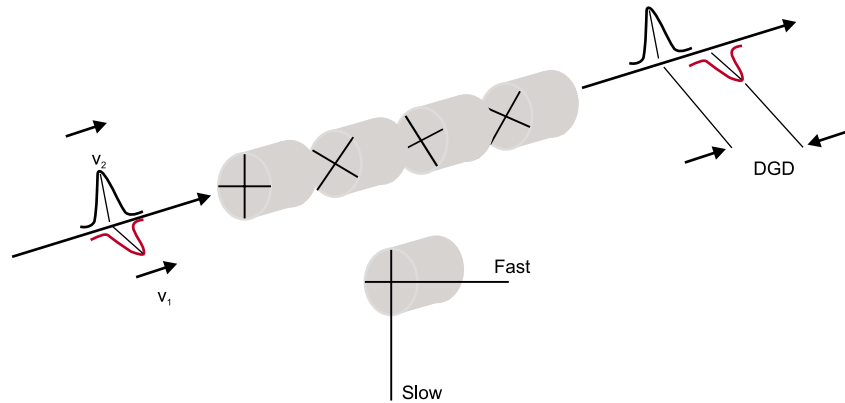

Figure 5. Strong mode coupling in telecommunications optical fiber.

Both PSPs and DGD vary with wavelength (figure 4). The biggest factor affecting the DGD distribution is temperature. Only a few degrees of variation is enough to completely skew the data. In addition, any human intervention on the fiber link, changing the fiber layout, will bring the same consequences.

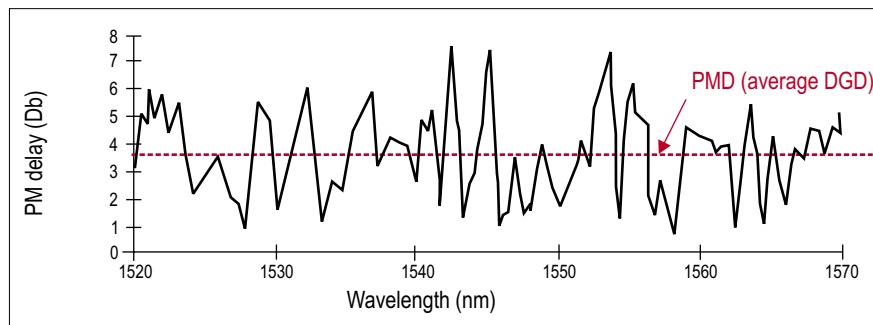

Figure 6. DGD variation over a range of wavelengths.

DGD distribution follows a Maxwellian curve, as shown on the figure 7.

As a result, the information of the DGD at one wavelength is valid only at a given time..



Figure 7. A Maxwellian distribution of the differential group delay.

From [the] data. DGD varies slowly over time but rapidly over wavelength...data showed good agreement with a Maxwellian distribution. The frequency averaged mean DGD [emphasis added] varied about 10% or less during periods that showed significant temperature swings.¹⁾

One commonly accepted parameter used to characterize the PMD delay is the mean DGD across a certain wavelength range ($\Delta\tau$), and is expressed in [ps].

$$\text{Mean DGD} = (\Delta\tau)$$

The mean DGD is proportional to the square root of the length of the fiber. If the mean DGD is doubled, the fiber length must be increased by a factor of four.

The PMD coefficient, $\Delta\tau_c$ [ps/ $\sqrt{\text{km}}$], is used to express the PMD delay as a function of the fiber length. $\Delta\tau = \Delta\tau_c \times \sqrt{L}$; where L is length of the fiber

The PMD is defined, then, using up to four main parameters:

- PMD delay [ps] or mean DGD
- PMD coefficient [ps/ $\sqrt{\text{km}}$]
- Second order PMD delay or DGD₂ [ps/nm]
- Second order PMD coefficient or PMD₂, [ps/(nm × km)]

Second Order PMD

The second order PMD describes how polarization induced delay, varies with wavelength,. It provides the indication of the wavelength dependency of the PMD delay.

There are two contributions:

- Rate of change of DGD vs Wavelength
- It describes the change of direction of PSPs

Second order PMD has to be added to chromatic dispersion figures, further limiting the CD constraints.

In fact, only very high speed (≥ 40 Gb/s) transmission systems are affected by the second order PMD.

Limiting Fiber Parameter

The mean DGD causes the transmission pulse to broaden when travelling along the fiber, generating distortion and increasing bit-error-rate (BER) of the optical system. The consequence is limitation of the transmission distance for a given bit rate.

PMD decreases with:

- Better fiber manufacturing control (fiber geometry)
- PMD compensation modules

PMD is more an issues for old G.652 fibers (<1996) than newer G.652, G.653, G.655 fibers.

If the maximum PMD delay is known, the maximum admissible fiber length can be deduced.

$$L = \frac{\Delta\tau^2}{\Delta\tau_{\text{cmax}}^2}$$

The statistical character of the PMD is taken into account where defining the maximum tolerable PMD delay as 10% of the bit length TB for a system, without disturbing the network performance by more than 1 dB loss, at 1550 nm, with NRZ coding

$$\Delta\tau_{\text{max}} \leq \frac{T_B}{10}$$

¹⁾Analysis and comparison of measured DGD data on buried single-mode fibers. Allen et al 2002

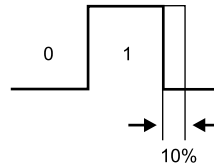

Maximum allowable shift of the bit length

Considering a transmission speed of 10 Gb/s, the bit length (100 ps) can be determined and then used to calculate the theoretical maximum PMD delay: $\Delta\tau = 0.1 * 100 \text{ ps} = 10 \text{ ps}$

In practice, some systems can accept up to 13-14 ps, depending on the coding structure.

The result of this calculation according to different transmission speeds is summarized in the table below.

Bit Rate	SDH Format	SONET Format	Equivalent Timeslot (UI)	PMD Delay Limit	PMD Coefficient for 400 km
1.2 Gb/s	-	OC-24	803 ps	80 ps	<4 ps/ $\sqrt{\text{km}}$
2.5 Gb/s	STM-16	OC-48	401 ps	40 ps	<2 ps/ $\sqrt{\text{km}}$
10 Gb/s	STM-64	OC-192	100 ps	10 ps	<0.5 ps/ $\sqrt{\text{km}}$
40 Gb/s	STM-256	OC-768	25.12 ps	2.5 ps	<0.125 ps/ $\sqrt{\text{km}}$

Table 1. The maximum PMD delay as a function of the bit rate.

This PMD limits are used to determine the maximum admissible fiber length.

Following, for a typical transmission system, is the maximum PMD coefficient as a function of length, at a given transmission bit rate.

This graph is provided with these assumptions: The PMD is considered to be Maxwellian, NRZ coding is used, 1550 nm lasers are used, a maximum power penalty of 1 dB is acceptable, a BER is typically between 10^{-9} and 10^{-12} . With this in mind, the following formula could be applied (L is the distance in km, B the bit rate in Gb/s, PMD the PMD value in ps/ $\sqrt{\text{km}}$):

$$L = \frac{10^4}{(B * \text{PMD})^2}$$

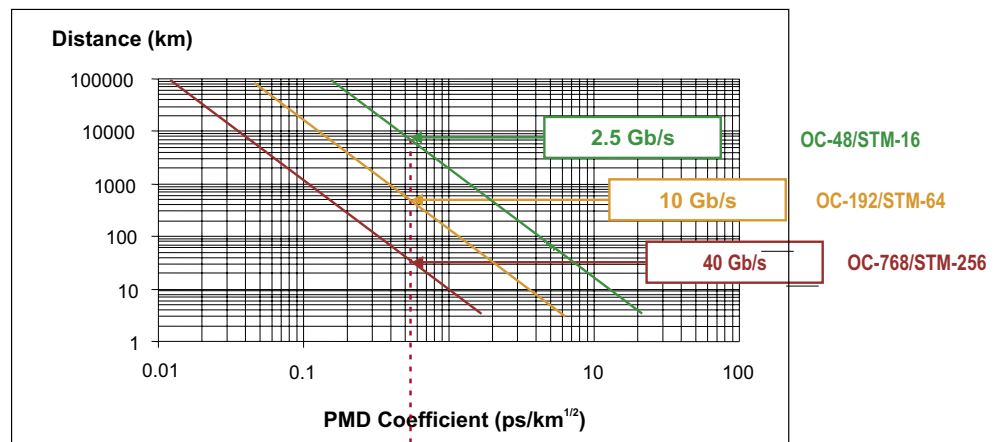

For PMD = 0.5 ps/ $\sqrt{\text{km}}$, the maximum distance is: 6400 km at 2.5 Gb/s, 400 km at 10 Gb/s, 25 km at 40 Gb/s

Figure 8. Maximum distance as a function of PMD coefficient and data bit rate.

When to Test PMD

PMD testing is becoming a requirement when the transmission bit rate per channel rises or with the increase of the corresponding distance. It appears that the measurement shall be at least performed when the bit rate is equal or higher than 10 Gb/s. However, for fibers older than 1996 or for some applications, such as analog cable TV applications, lower transmission bit rates will be affected by PMD.

As a summary, the main circumstances in which PMD measurement will be required are:

- Qualification during fiber manufacturing
- Qualification during cable manufacturing
- Installation of new fiber networks, for 10 Gb/s bit rate or higher.
- Installation of ultra long haul networks at 2.5 Gb/s or higher
- Upgrade of current networks for 10 Gb/s bit rate or higher

Fiber and cable manufacturers are specifying their fibers with $0.5 \text{ ps}/\sqrt{\text{km}}$ maximum, according to the ITU-T recommendations. However, current manufactured fibers are easily better than $0.2 \text{ ps}/\sqrt{\text{km}}$

As PMD is a statistical measurement and, because it is sensitive to external environment, it is recommended to perform different measurements at different time intervals so that long term fluctuation of PMD can be monitored, providing better records of the fiber cable.

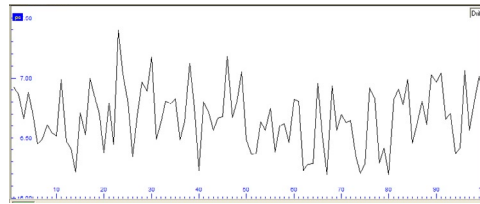

Figure 9. A representation of the fluctuation of a long-term PMD delay measurement.

High PMD Values

If the PMD measurement is higher than the tolerable limit for a given bit rate, the fiber is classified as “sensitive” to PMD for that particular transmission speed. For a passing PMD result (within the tolerable limit) at a given bit rate, the fiber cannot be classified as “non-PMD sensitive.” Instead, it should be classified as “suitable for the particular transmission rate” at the given time.

Currently, there is no simple and low-cost component that allows for the correction of a link with a high PMD value. Although a number of components are under qualification and development, at this time, very few PMD compensators have been deployed in the field.

Dispersion is clearly important in limiting the distance (or the transmission bit rate) for a given network application. Therefore, several solutions have been developed that allow for the compensation of the effect of PMD on the transmission link, including transmitting over shorter distances, transmitting at lower bit rates per wavelength, using low chirp lasers, using dispersion-managed RZ optical soliton transmission, or using forward error correction (FEC) transmission.

PMD Compensation Techniques

It is particularly difficult to counteract PMD due to its statistical nature and its variation over the time and wavelength. The stochastic nature of PMD is such that reducing the impact of PMD does not necessarily imply the complete cancellation of the effect, rather the reduction of the outage probability due to PMD. This process is called PMD mitigation.

Several PMD compensation techniques have been proposed in the past few years. They can be classified into two main categories:

- Electrical PMD compensation
- Optical PMD compensation

Electrical compensation of PMD involves equalizing the electrical signal after the photodiode. This equalization can be implemented in many ways: transversal filter (TF), non-linear decision feedback equalizer (DFE), phase diversity detection. Electrical compensation schemes, in general, are robust and will improve the signal against all kinds of transmission impairments. On the other hand, they do not perform as well as optical PMD compensators and also they require high-speed electronics for better performance.

Optical PMD compensation attempts to reduce the total PMD impairment caused by the transmission fiber and the compensator. The block diagram of a general optical PMD compensation scheme is shown in Figure 8. It has an adaptive counter element, a feedback signal, and a control algorithm.

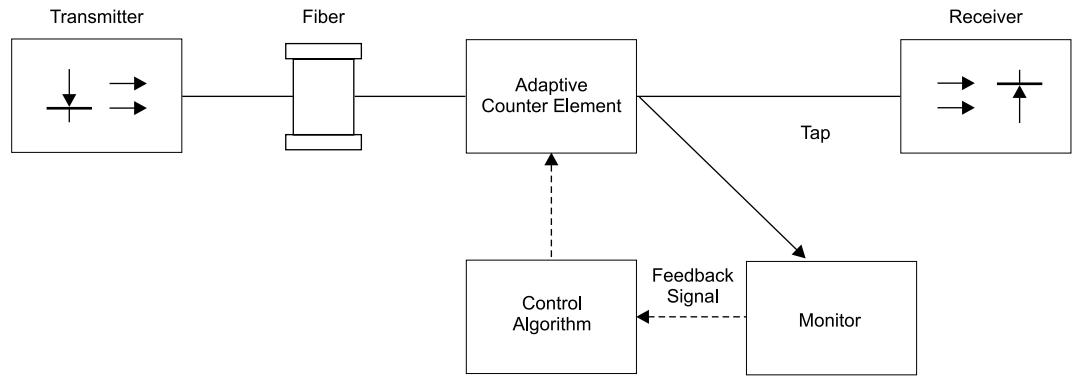

Figure 10. A schematic diagram of optical PMD compensation.

The adaptive counter element is the core of any PMD compensator. It must be able to counteract PMD impairments and be tunable. The feedback signal is required to provide the PMD information to the controlling algorithm of the compensator.

PMD International Standards and Recommendations

Standards such as ITU-T, IEC, and TIA/EIA, have provided guidelines and recommendations related to PMD and its associated measurements. Following is a list of the main references related to PMD.

Standard	Description
ITU-T G.650.2	Definition and test methods for statistical and non-linear attributes of singlemode fiber and cable
ITU-T G.652	Characteristics of a singlemode optical fiber and cable
ITU-T G.653	Characteristics of a dispersion-shifted singlemode optical fiber and cable
ITU-T G.654	Characteristics of a cut-off shifted singlemode optical fiber and cable
ITU-T G.655	Characteristics of a non-zero dispersion-shifted singlemode optical fiber and cable
ITU-T G.656	Characteristics of a fiber and cable with non-zero dispersion for wideband transport
IEC/TS 61941	Technical specifications for polarization mode dispersion measurement techniques for singlemode optical fibers
IEC 60793-1-48	Measurement methods and test procedures - Polarization mode dispersion
GR-2947-CORE	Generic requirements for portable Polarization Mode Dispersion (PMD) test sets
TIA/EIA-455-FOTP-113	Polarization Mode Dispersion measurement for singlemode optical fiber by the fixed analyzer method
TIA/EIA-455-FOTP-122A	Polarization Mode Dispersion measurement for singlemode optical fiber by Stokes parameter evaluation
TIA/EIA-455-FOTP-124A	Polarization Mode Dispersion measurement for singlemode optical fiber by interferometry
TIA/EIA-TSB-107	Guidelines for the statistical specification of Polarization Mode Dispersion on optical fiber cables

Table 2. The main standards, guidelines, and recommendations relating to PMD.

PMD Test Methods Description

As described in the test and measurement standards, there are different ways of measuring PMD in the field. Only four methods will be described below. Other methods exist but are dedicated to production/lab testing (Poincaré Sphere, State of Polarization, modulation phase shift, pulse delay, time delay, and the base-band curve fit methods).

The first 3 methods below are classified following the IEC-60793-1-48 international standard, where GINTY method is not an IEC standardized method yet published. All test methods are also published by the ITU-T G650.2. The EIA/TIA provides a recommendation for each individual test solution.

Fixed Analyzer Method (or Wavelength Scanning)

Equipment needed

This method requires a broadband polarized source and a polarized (variable) optical spectrum analyzer (OSA).

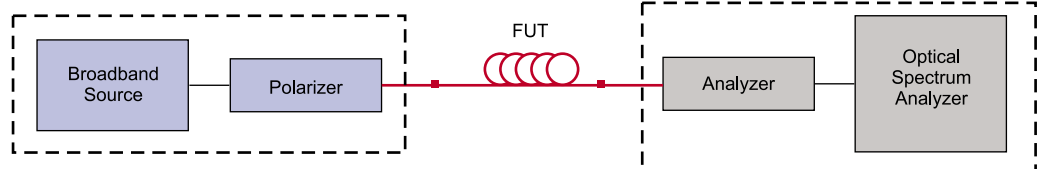

Principle of the method

From the power fluctuations spectrum, the mean period of the intensity modulation is measured. This is realized by counting the number of extrema (i.e., measuring the rate at which the state of polarization changes as wavelength changes), in order to give a mean DGD. Alternatively, a Fourier transform into the time domain will also give a graph, and the RMS DGD value is determined from the standard deviation of the Gaussian curve (for fiber links with strong mode coupling).

Jones Matrix Eigenanalysis (JME) (or Stokes Parameter Evaluation)

Equipment needed

This method requires a tunable narrowband source with three linear polarizers and a polarimeter.

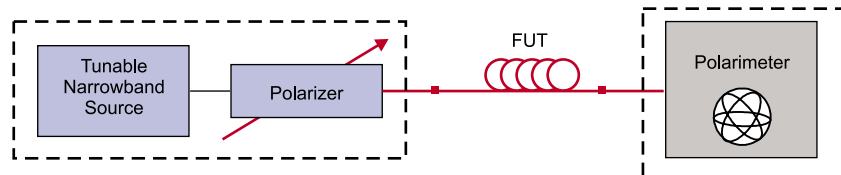

Principle of the method

The three known states of polarized light enable the polarimeter to obtain the Jones matrix. The Jones matrix values at pairs of adjacent wavelengths provide the DGD value. The PMD is then calculated by simply averaging the obtained DGD values over the wavelengths.

Interferometry: Traditional Method (TINTY)

Equipment needed

This method requires a broadband polarized source and an interferometer (Mach-Zehnder or Michelson).

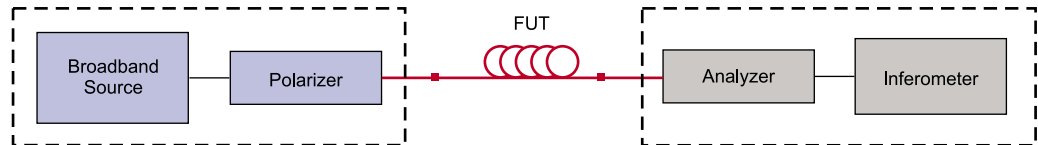

Principle of the method

For fiber links (usually strong mode coupling), the result is an interferogram with random phases, and the mean DGD value is determined from the standard deviation of its curve. Nevertheless, the fringe envelopes obtained are a combination of two functions. An algorithm must be used to try to remove the central auto correlation peak which contains no PMD information.

Interferometry: Generalized Method (GINTY)

Equipment needed

This method requires a broadband polarized source, an interferometer (Mach-Zehnder or Michelson) with a polarization beam splitter, and two polarization scramblers.

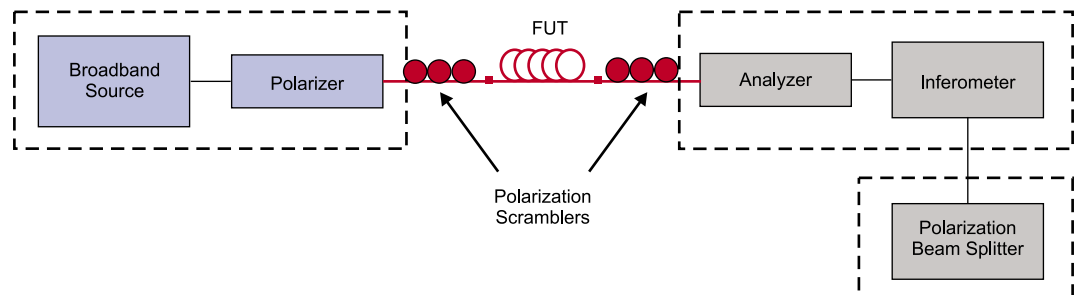

Principle of the method

For fiber links (usually strong mode coupling), the result is an interferogram with random phases, and the mean DGD value is determined from the standard deviation of the curve. This time, the two signals of the polarization diversity detection allow to removing the contribution of the source auto-correlation peak. It is possible to obtain the interferogram without the central peak thanks to the polarization beam splitter. However the real benefit of this method is only obtained by the use of polarization scramblers, allowing to improving absolute uncertainty of the measurement results.

Comparison of the Different PMD Test Methods

Inter-comparison results have been made by the international organizations, and at the present time, inter-laboratory measurements indicate that there is an agreement of +/-10% to +/-20% between all the different methods. This is well described in the TIA/EIA-455 PMD documents. There is fairly good statistical agreement between fixed analyzer and Jones Matrix Eigenanalysis. On the other hand, the interferometry and fixed analyzer with Fourier transform are having good statistical agreement. However there may have possible differences between the two types of methods.

The following measurements (DGD in ps) have been performed in the field, on different link configurations, with the same acquisition conditions.

	Distance	TINTY Method	Fixed Analyzer Method	Difference
New fiber measurements (on drums)	100 km	0.77 ps	0.85 ps	10%
New deployed fiber measurements (>2000)	69 km	0.282 ps	0.282 ps	1%
	89 km	0.519 ps	0.479 ps	8%
Old fiber measurements (<1993)	16 km	7.26 ps	6.16 ps	16%
	32 km	8.37 ps	7.0 ps	16%

Table 3. DGD measurements showing the differences between the TINTY and Fixed Analyzer PMD test methods.

This data confirms that the differences between the Interferometry (TINTY) and Fixed Analyzer methods, published by the TIA/EIA, are in the range of 10% to 20%. Furthermore, repeat measurements show results variation with both methods due to the statistical changes of PMD values.

Table 4 shows the advantages of the different PMD test methods.

Fixed Analyzer Method	JME Method	TINTY Method	GINTY Method
<ul style="list-style-type: none"> Established in the market High dynamic range (>45 dB using a handheld, rugged light source) Good absolute uncertainty Minimum DGD measurement range is suitable for any fiber Possible to measure through multiple EDFAs Very fast measurement (from 5 s) A robust and field-dedicated instrument with no moving parts (Fabry-Perot filter technology); limits risk of failure; small and light Very easy to use; no specific parameter settings necessary 	<ul style="list-style-type: none"> High dynamic range (up to 50 dB using a benchtop light source) Good absolute uncertainty Minimum DGD measurement range is suitable for any fiber Possible to measure through multiple EDFAs Averaging is not necessary, but one acquisition is required for each wavelength 	<ul style="list-style-type: none"> Established in the market High dynamic range (up to 65 dB using a benchtop light source) Good absolute uncertainty (but includes a systematic error due to the interferogram central peak removal) Minimum DGD measurement range is suitable for any fiber 	<ul style="list-style-type: none"> High dynamic range (up to 47 dB using a benchtop light source) Good absolute uncertainty Minimum DGD measurement range is suitable for any fiber Possible to measure through multiple EDFAs Very fast measurement (from 5 s)
	<ul style="list-style-type: none"> Not sensitive to input polarization Not sensitive to mode coupling Second order PMD is measured directly 		<ul style="list-style-type: none"> Not sensitive to input polarization when using the polarization scramblers

Table 4. Advantages of the different PMD test methods.

Table 5 shows the disadvantages and limitations of the different PMD test methods.

Fixed Analyzer Method	JME Method	TINTY Method	GINTY Method
	<ul style="list-style-type: none"> • Cost too high for a field solution • Laboratory solution, not field-proven nor convenient (uses a benchtop light source) 	<ul style="list-style-type: none"> • Not field convenient, risk of failure due to moving parts 	<ul style="list-style-type: none"> • New interferometry method • Not field convenient, risk of failure due to moving parts; polarization scramblers required
<ul style="list-style-type: none"> • Averaging necessary, but only over 30 dB total loss 		<ul style="list-style-type: none"> • Long measurement time; averaging necessary • Not easy to use; the correct DGD range must be set before testing • Not possible to measure through EDFAs 	<ul style="list-style-type: none"> • Limited dynamic range with a portable light source
<ul style="list-style-type: none"> • Second order PMD not measured directly, but calculated 		<ul style="list-style-type: none"> • Second order PMD not measured directly, but calculated 	<ul style="list-style-type: none"> • Second order PMD not measured directly, but calculated
<ul style="list-style-type: none"> • Maximum PMD limited to 60 ps; suitable for any telecom fiber 	<ul style="list-style-type: none"> • Maximum PMD limited to 50 ps; suitable for any telecom fiber 		
<ul style="list-style-type: none"> • Sensitive to input polarization 		<ul style="list-style-type: none"> • Sensitive to input polarization 	<ul style="list-style-type: none"> • Sensitive to input polarization when no polarization scramblers are in place

Table 5. Disadvantages and limitations of the different PMD test methods.

Conclusion

There are no simple theoretical predictors of installed cable PMD, but PMD is more critical with older fibers that were manufactured with less geometrical control than today.

PMD remains the dominant bit rate-limiting effect in long single mode fibers, when chromatic dispersion is reduced by state-of-the-art techniques like compensated fibers or chirped gratings. PMD has to be measured in order to characterize the fiber dedicated to this transmission speed.

Related Documents

1. Measurement Methods and Test Procedures - Polarization Mode Dispersion IEC 60793-1-48.2003-05
2. ITU-T G.650.2, Definitions and test methods for statistical and non-linear related attributes of single-mode fibre and cable, 2005-01.
3. Polarization-Mode Dispersion Measurement for Single-Mode Optical Fibers by the Fixed Analyzer Method, draft TIA FOTP-113 (1997-02)
4. Polarization-Mode Dispersion Measurement for Single-Mode Optical Fibers by Jones Matrix Eigenanalysis, draft TIA FOTP-122-A (2002-08)
5. Polarization-Mode Dispersion Measurement for Single-Mode Optical Fibers by the Interferometric Method, draft TIA FOTP-124-A (2004-02)
6. "Polarization Mode Dispersion", Corning Cable System, Engineering Services Department, Application Engineer Note 48, Revision 2, 2002-12.
7. Ricci, Vincent PhD Corning Corp "Long Distance Dedication - Polarization Mode Dispersion." 2001-07
8. Polarization-Mode Dispersion in High-Speed Fiber-Optic Transmission Systems, Henrik Sunnerud, Magnus Karlsson, Chongjin Xie, Member, IEEE, and Peter A. Andrekson, Senior Member, IEEE, Member, OSA
9. Allen, Christopher, Pradeep Kumar Kondamuri, Douglas L. Richards, and Douglas C. Hague. "Analysis and Comparison of Measured DGD Data on Buried Single-Mode Fibers." Symposium on Optical Fiber Measurements, Boulder, CO, pp. 195-198, Sept. 24-26, 2002
10. Galtarossa, A., et. al, "In-Field Comparison Among PMD Measurement Techniques." JOURNAL OF LIGHTWAVE TECHNOLOGY, VOL 14, No 1, 1996)
11. Hanson, T.A. "Polarization Mode Dispersion and Related Topics." 2000-10.
12. Kapron, Felix, Ariel Dori, John Peters, and Helmut Knehr. "Polarization Mode Dispersion: Should You Be Concerned?" Bellcore.
13. Karlsson, Magnus, Jonas Brentel, and Peter A. Andrekson. "Long-Term Measurement of PMD and Polarization Drift in Installed Fibers." JOURNAL OF LIGHTWAVE TECHNOLOGY, VOL. 18, NO. 7, JULY 2000

All statements, technical information and recommendations related to the products herein are based upon information believed to be reliable or accurate. However, the accuracy or completeness thereof is not guaranteed, and no responsibility is assumed for any inaccuracies. The user assumes all risks and liability whatsoever in connection with the use of a product or its applications. JDSU reserves the right to change at any time without notice the design, specifications, function, fit or form of its products described herein, including withdrawal at any time of a product offered for sale herein. JDSU makes no representations that the products herein are free from any intellectual property claims of others. Please contact JDSU for more information. JDSU and the JDSU logo are trademarks of JDS Uniphase Corporation. Other trademarks are the property of their respective holders. © 2006 JDS Uniphase Corporation. All rights reserved. 30137416 001 0507 PMD.WP.FOP.TM.AE

Test & Measurement Regional Sales

NORTH AMERICA TEL: 1 866 228 3762 FAX: +1 301 353 9216	LATIN AMERICA TEL:+55 11 5503 3800 FAX:+55 11 5505 1598	ASIA PACIFIC TEL:+852 2892 0990 FAX:+852 2892 0770	EMEA TEL:+49 7121 86 2222 FAX:+49 7121 86 1222	WEBSITE: www.jdsu.com/fiberopticstest
---	--	---	---	---