

OTN paves the way for the transport medium of the future – Requirements for measuring equipment

Which communications standard will be used for tomorrow's telecommunications networks? SDH, though tried and tested, seems too inflexible and is very complex for packet-switched transmissions; the LAN standard Ethernet has no network management function; and OTN to ITU-T Rec. G.709 with additional features for optical networks still only integrates the SDH hierarchy. The challenge facing a communications standard is that of flexibly transmitting existing and possible future data rates across a highly complex telecommunications network using structures that are as efficient as possible, while at the same time fulfilling the high demands of a network management function (Figure 1).



Written by:

Peter Winterling
Senior Solution Specialist
Optical Products, JDSU

Figure 1: Measurements at transmission systems according to ITU Standard G.709

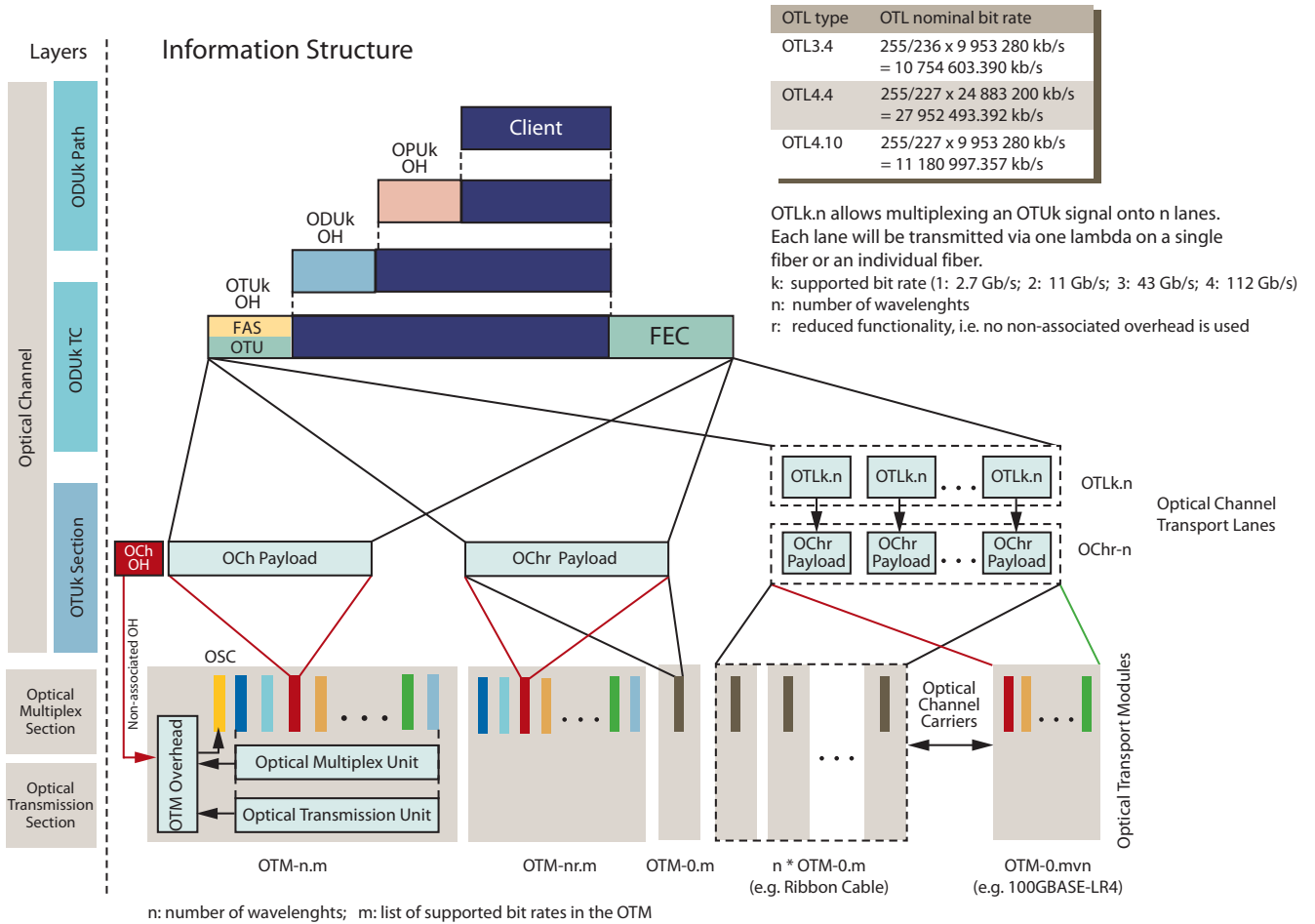

Figure 2: OTN signal structure according to ITU-T Recommendation G.709

The introduction of 100 Gigabit Ethernet (GbE) technology was eagerly awaited and perhaps the highlight of 2009. The 40/43 Gbit/s communications technology widely installed last year would seem to be just a short intermediate phase before the “right” communications capacity is installed – at least from the network planning point of view.

At the same time, but with much less fanfare, the course is being set for the communications medium of the future. The 40/43 Gbit/s interface is within the SDH/OTN hierarchy standardized by the ITU, and 100 Gbit/s is defined by IEEE standardization. SDH (Synchronous Digital Hierarchy), developed some 20 years ago, is used in the transport network as a reliable transmission medium, optimized for maximum communications quality.

The later introduction of optical communications technology has made it possible first of all to transmit multi-channel systems over very long distances without electrical regeneration, and secondly to route individual wavelengths in a meshed network. The telecommunications network is turning into a photonic network. The OTN standard (Optical Transport Network) according to ITU-T Rec. G.709 has kept up with this development with additional signaling performance properties for the optical channels. In terms of hierarchy formation, OTN initially strictly follows the SDH hierarchy. OTN is increasingly viewed as the future standard of telecommunications, even though for various reasons its introduction as a replacement is taking place only very sluggishly. During this time, the SDH standard has been expanded to also allow for the transmission of packet-switched data rates from the IEEE world as payloads (client signals) in SDH frames.

A high degree of flexibility has been achieved for SDH as transport medium with GFP, VCAT, and LCAS, even though the OTN frame is still needed for signaling in the optical network.

It is no coincidence that at the same time as the market introduction of 100 Gigabit Ethernet, the ITU standardization group has been working on an extension of the OTN standard across all hierarchy levels, which will put this transport medium in position as the clear favorite for telecommunications. Figure 2 shows the additions.

OTN according to ITU-T Rec. G.709 as transport medium

The IEEE's asynchronous, packet-switched Ethernet standard and the SDH synchronous digital hierarchy have long been contesting as to which standard is better for telecommunications. SDH was developed as a global communications medium for digital transmission of voice signals at 2 Mbit/s or the 1.5 Mbit/s signals from the American region (SONET, synchronous optical network). STM-1 (level 1 Synchronous Transport Module), with a maximum payload of 150 Mbit/s, can combine together 63 VC-12 (virtual containers), each with one 2 Mbit/s frame. The SDH hierarchy continues up to STM-256, each level being a quadruple of the previous one.

Originally developed for LANs, the IEEE standard Ethernet is considered to be a very reasonably priced technology and has extended its sphere of influence into transmission networks. The rapid increase in the volume of data in the field of computing, together with the ever rising use of the Internet, has consolidated the Ethernet standard. Even extremely time-critical signals, such as telephony or live video transmissions, have been adapted to the real-time incompatible transmission medium Ethernet by means of complex procedures (for example voice over Internet protocol, VoIP). Nowadays, the packet-switched Ethernet is an extremely flexible, versatile, yet cost-effective way of transmitting data over the telecommunications network and is currently the clear favorite for transmitting various source signals. Additional signaling information for the communications channel is needed in a transport network to enable a large network to be operated in a well organized and efficient manner with the aid of a network management system. This particular function was one of the foremost basic requirements for the SDH standard. Equipped with powerful signaling mechanisms up to and

including automatic backup switching for malfunctioning communications equipment, this standard forms the basis of centralized network management, even in widespread and highly meshed networks. Unfortunately, the SDH standard, originally developed as a transport medium from one cross connect to the next via one or more regenerators, does not cover the needs of today's optical networks. Ten years after the introduction of SDH components, the at that time still unforeseen development of optical technology laid the foundation for photonic networks. DWDM transmission using purely optical amplification, optical add/drop functions and switching of individual optical channels router nodes and access nodes has transformed the SDH sphere into a photonic architecture. The path information that is so important for network management is thus unavailable in the SDH frame.

Consequently, the ITU standardized a new asynchronous transport medium to cater for the possible new network architectures. The frame structure of the optical transport network module OTM according to ITU-T Recommendation G.709 is related to SDH but is now oriented on the optical communications channel, no longer bound to the implementation on the hardware side. For the first time, forward error correction (FEC) was integrated into circuit switched communications to rectify transmission errors. This increases the data transfer rate by about 7%. With this exclusive focus on the transport network, the data transfer rates are 2.7 Gbit/s for OTU1 (level 1 optical transport unit), 10.7 Gbit/s for OTU2, and 43 Gbit/s for OTU3. The payload for the time being consists of SDH signals like STM-16, STM-64, and STM-256.

This new communications method initially had modest success, because optical cross connects after much delay have only recently begun to be built into new networks and it was not economically justifiable to make the investment needed to replace SDH line equipment that had only just been installed. The path of integrating asynchronous Ethernet data transfer rates via GFP into SDH, which then in turn uses the OTN transport frame, is technically ingenious but complicated. If OTN could define corresponding mapping procedures for the Ethernet rates that are distinctly different from the data rates, the technically complex and expensive route via SDH would not be necessary. This would make OTN the new, universal transmission medium for telecommunications networks. This is precisely the path being followed by the additional ITU standardization.

OTN type	Nominal OTU bit rate	ODU type	Payload data rate (Client)
–	–	ODU0	1-Gigabit-Ethernet (LAN)
OTU1	$255/238 \cdot 2,488\,320 \text{ Gbit/s} = 2,666\,057 \text{ Gbit/s}$	ODU1	STS-48/STM-16
OTU1e	$255/238 \cdot 10,312\,500 \text{ Gbit/s} = 11,049\,107 \text{ Gbit/s}$	ODU1e	10-Gigabit-Ethernet (LAN)
OTU1f	$255/238 \cdot 10,518\,750 \text{ Gbit/s} = 11,270\,089 \text{ Gbit/s}$	ODU1f	10-Gigabit-Fibre-Channel
OTU2	$255/237 \cdot 9,953\,280 \text{ Gbit/s} = 10,709\,255 \text{ Gbit/s}$	ODU2	STS-192/STM-64 (WAN)
OTU2e	$255/237 \cdot 10,312\,500 \text{ Gbit/s} = 11,095\,730 \text{ Gbit/s}$	ODU2e	10-Gigabit-Ethernet (LAN)
OTU2f	$255/237 \cdot 10,518\,750 \text{ Gbit/s} = 11,317\,642 \text{ Gbit/s}$	ODU2f	10-Gigabit-Fibre-Channel
OTU3	$255/236 \cdot 39,813\,120 \text{ Gbit/s} = 43,018\,414 \text{ Gbit/s}$	ODU3	STS-768/STM-256
OTU3e1	$255/236 \cdot 4 \cdot 10,312\,500 \text{ Gbit/s} = 44,570\,974\,576 \text{ Gbit/s}$	ODU3e1	4 · ODU2e
OTU3e2	$243/217 \cdot 16 \cdot 2,488\,320 \text{ Gbit/s} = 44,583\,356 \text{ Gbit/s}$	ODU3e2	4 · ODU2e
OTU4	$255/227 \cdot 99,532\,800 \text{ Gbit/s} = 111,809\,973 \text{ Gbit/s}$	ODU4	100-Gigabit-Ethernet

Table OTU types and their transmission capacity

However, there are some obstacles to be overcome on the way to a universal transmission medium. Some data transfer rates at the 10 Gbit/s level exceed the payload range of OTN. Integration of these signals can be achieved by increasing the clock frequency, since OTN is based on an asynchronous network structure. This results in so-called overclocked rates. The Table shows the bit rates and mappings for OTN that have already been defined.

Different mapping schemes are used for OTU1 and OTU2, see Figure 3. Both are used for integrating the new source signals. A constant stuffing zone is additionally inserted in OTU2, which is why the frame has to be clocked at a faster rate for the same amount of payload information. For a 10 Gigabit Ethernet LAN with a data transfer rate of 10.3125 Gbit/s, this results in the transmission side OTU1e signal using the OTU1 mapping scheme and OTU2e using the OTU2 mapping scheme. Using the same scheme for mapping fiber channel connections, two further bit rates result, namely OTU1f and OTU2f, because 10 Gigabit FC has a somewhat higher data transfer rate than 10 Gbit Ethernet LAN. Nowadays at least, all these data transfer rates can generally be handled by just one transponder. This means that in the physical layer, and therefore on the hardware side, only one interface is needed.

IEEE signals need a transport layer

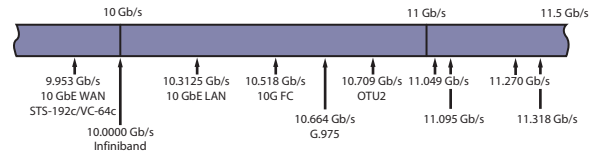

Structure of ODU1 and ODU2

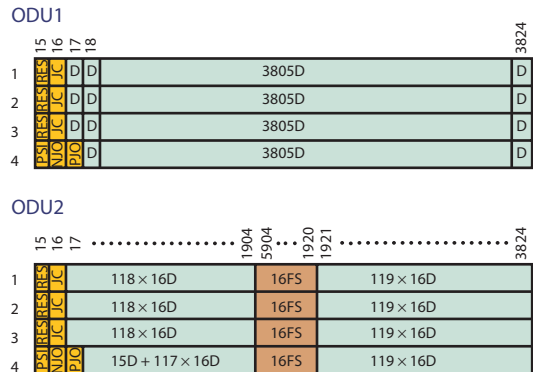

Figure 3: Variants at 10 Gbps and multiplex schemes

Multiplexing in an optical transport network

OTN frames will increasingly also be encountered as client (payload) signals. This means that they have to be transmitted unchanged. Payload signals are multiplexed into higher hierarchy levels at the transition from metro network to wide area network to ensure the efficiency of the wide area network transmission, and a further hierarchy level is possible as a result of the blanket coverage installation of the 40/43 Gbit/s level.

In a point-to-point connection with SDH as the source signal, the corresponding SDH hierarchy was first of all formed by multiplexing before the OTN frame was generated for transmission in the optical network. OTN was thus only encountered on the transmission side. Now, it is hardly sensible to unpack the STM-16 payload from an OTU1 signal and then to multiplex this into an STM-64 signal as per SDH and then to form an OTM OTU2 frame from this. The advantages of OTN would then be reduced to forward error

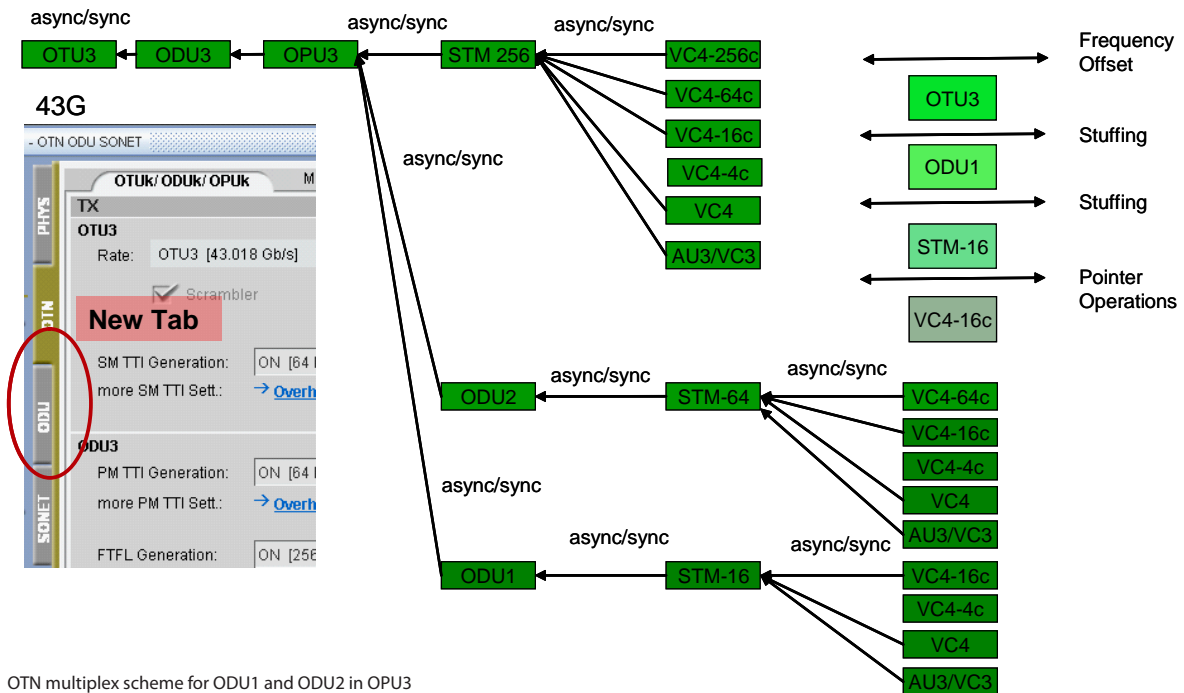

Figure 4 OTN multiplex scheme for ODU1 and ODU2 in OPU3

Resolving the OTN frame and reverting to the original source signal (de-wrapping) is not always sensible and sometimes not permissible. The same situation occurs at the interconnection points between network territories. Here too, the incoming signal must be passed on without impairing or changing the frame structure. This is achieved by means of one of the major fundamental characteristics of OTN, the optical channel layer model (OCh). The “tandem connection” function is included in the OTN frame for this purpose. This function is only guaranteed if the OTN frame is retained. Integration into the next higher hierarchy level is desired at these interconnection points, so a method of OTN multiplexing must be created.

correction FEC on the transmission side. The new route for OTN multiplexing has already been described in principle in ITU-T Rec. G.709 and now needs to be specified in detail by additions to this standard. Figure 4 shows the path for multiplexing an ODU1 or ODU2 into an OPU3. An ODU (Optical Data Unit) comprises the payload signal and its associated overhead. The existing error correction does not need to be included as this is only ever used for one transmission segment. A new FEC is generated via the new frame for the subsequent transmission in the higher hierarchy level. The payload signal in an ODU1 so far mostly consists of a structured STM-16 frame. The procedure for mapping into an OPU2 or OPU3 (Optical Payload Unit) is therefore relatively uncomplicated. Because of the overclocked bit rates for the ODU2, multiplexing

into an OPU3 requires considerably more tolerance for the different clock rates.

Two-stage multiplexing is not yet envisaged. Nevertheless, an ODU2 can already contain four ODU1 frames. Corresponding clock tolerances must therefore be taken into account, and there are accordingly many alternatives for the adaptation into an OPU3. Figure 5 shows the equivalent multiplex structure for an ODU1 in an OPU2. The following adaptations are generally needed for a multiplex structure for OTN:

- The pointer activities of the SDH synchronous signal structure must be balanced out;
- The STM-16 signal clock must be equalized to the OTU1 by means of stuffing;
- The ODU1 signal clock must be equalized where there is multiplexing into an OPU2;
- Compensation of a clock frequency offset is needed for ODU2 to OPU3 when different payload signals are used (overclocked signals).

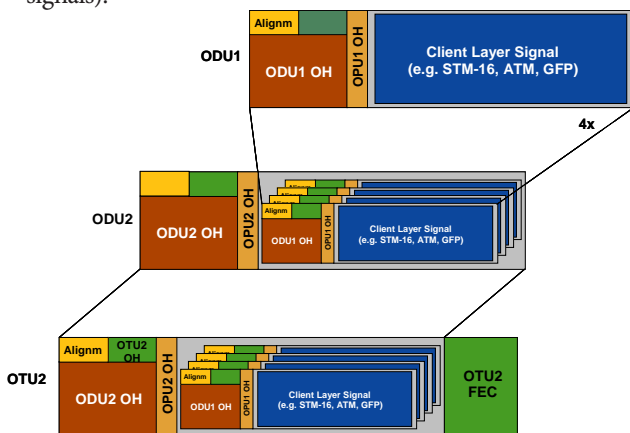

Figure 5: Multiplexing of ODU1 in OPU2 and OTU2 frames

Which source signals still need to be integrated?

Multiplexing is one step for OTN on the way to becoming a universal transport medium. It has long been established for telecommunications at 40/43 Gbit/s. IEEE standard 100 Gigabit Ethernet client signals will soon be accommodated.

Up till now, ITU has strictly followed SDH with the factor 4 in the formation of the hierarchy. OTU4 represents the first departure from this path. A quadrupling of the STM-256 bit rate, i.e. 160 Gbit/s plus FEC seems somewhat unreasonable, since an extremely high technical outlay is already required for serial transmission of 100 Gbit/s in

the existing telecommunications environment. There is also no sensible approach to the expansion of SDH into the next hierarchy level, namely STM-1024. Pressure on systems manufacturers and network operators to provide infrastructure for 40 Gbit/s came from IP carrier routing system manufacturers. The OC-768 SONET interface which corresponds to the European STM-256 variant was chosen in the absence of Ethernet standardization for bit rates above 10 Gigabit Ethernet. The demand for data transfer rates of above 10 Gbit/s is driven by the IP world and is thus defined exclusively as packet-switched communications. SDH will probably go no further than 40 Gbit/s. As a result, ITU has chosen to follow the IEEE bit rates for the next hierarchy level and has defined OTU4 with 112 Gbit/s in order to transmit the 100 Gigabit Ethernet payload.

Network engineers would very much like to integrate the widely-used 10 Gigabit Ethernet signals into the new 40/43 Gbit/s communications technology to make optimum use of the existing optical channels. One way of doing this would be to map the Ethernet signals into the SDH frame via the 10 Gigabit Ethernet WAN data rate reduction, and then to multiplex this with three more frames into an STM-256. This roundabout route via the SDH is, however, very complicated and is not particularly attractive. A second way would be to reduce the transmission rate of the four 10 Gigabit Ethernet signals by means of a high degree of transcoding in the physical coding sublayer (PCS) and then to map this directly into the payload zone of an OTU3 frame. The Ethernet world is tending towards multiplexing the four original 10 Gigabit Ethernet signals with a data transfer rate of 10.3125 Gbit/s into the OTU3 frame directly. Of necessity, this leads to an overclocked OTU frame, OTU3e, with a clock frequency of 44.58 Gbit/s and a payload range of 41.25 Gbit/s.

The method that will eventually be included in the standard for wide-area telecommunications using DWDM technology is currently under discussion within the ITU working groups.

Standardization of 100 Gigabit transmission using multi lane distribution (MLD) has led to a further very inexpensive method of communications for computer centers and campus networks. In this case, the 40 Gigabit Ethernet signal is transmitted through a single-mode or multimode fiber using four parallel wavelengths.

The question of other source signals that need to be integrated into a backbone network needs to be investigated on the way to generalizing the OTN transmission standard.

For many, this will be the route via SDH with GFP and VCAT. Probably the most common transmission signal used in metropolitan area networks as a communications link between companies and banks is 1 Gbit/s Ethernet. There is a majority preference in the ITU committee for similarly integrating this signal into OTN. A less expensive solution than that offered by SDH with GFP is desired here. An ODU0 frame analogous to the OTU1 frame is defined for this signal. With a gross bit rate of 1.25 Gbit/s, exactly two ODU0 fit into the volume of an OPU1 (Figure 6). This would integrate the Gigabit Ethernet signals in an ideal manner so they could be further communicated with minimal technical outlay. This also opens up the opportunity to multiplex ODU0 frames into an OPU2 or OPU3. This is not yet under consideration by the current round of working group discussions.

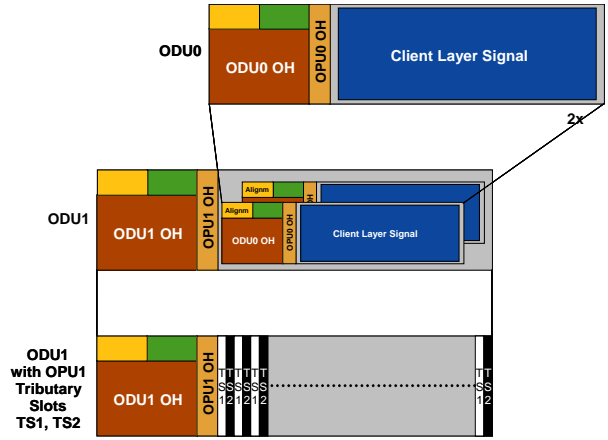

Figure 6 ODU0 frame for 1 Gigabit Ethernet source signal, multiplexed in OPU1
Further existing methods are listed in the ITU document G.Sup43 [2] by way of an appraisal. It remains to be seen which of these will be included in the standardization. Figure 7 shows the possible mapping structures for OTN with the various types of ODU multiplexing. Not all of these will be implemented. Experience will demonstrate which ones will be found most acceptable by the network providers.

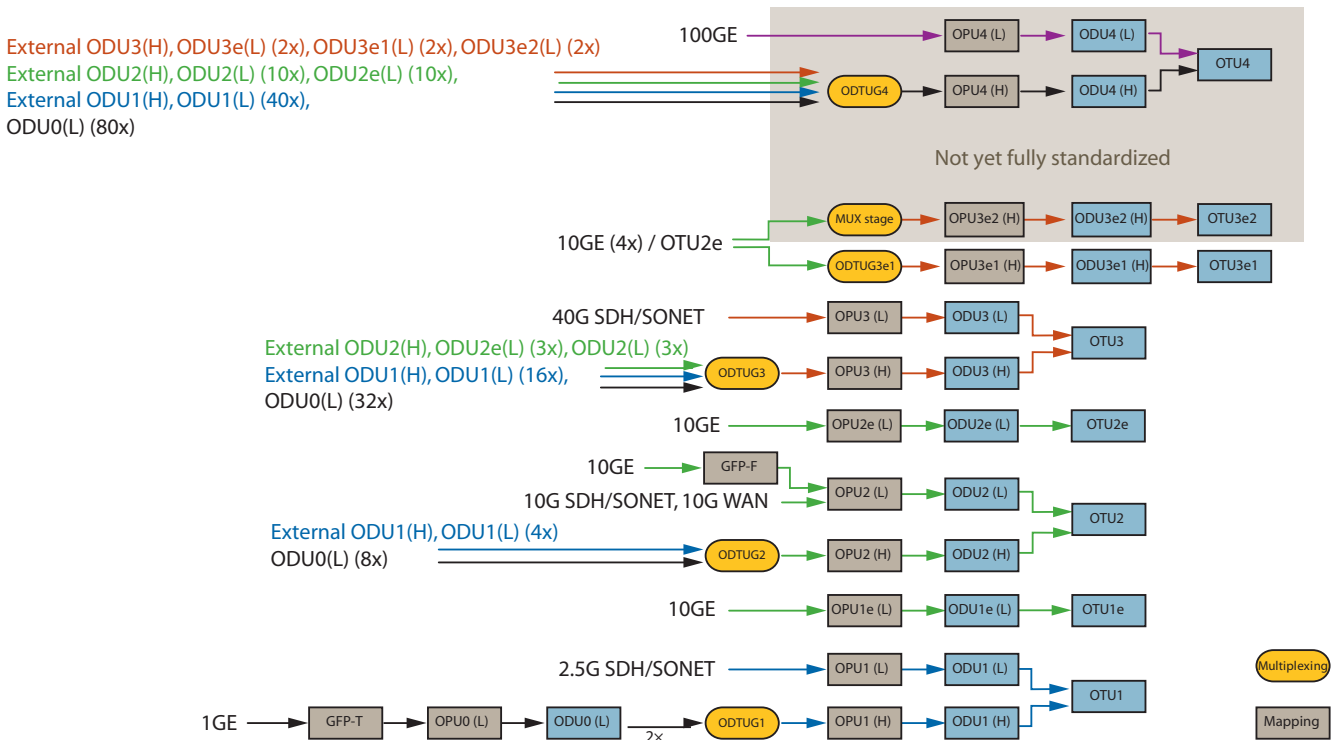

Figure 7: OTN mapping overview

The FiberChannel (FC) communications protocol still seems to be a bit of an outsider. This Ethernet-related protocol has its main use in storage area network (SAN) applications where maximum throughput of large data packets is to be achieved. Because of the time-critical confirmation messages in this protocol, integration into higher level transmission frames is problematical. Transmission is therefore usually in the form of a point-to-point connection and uses a separate wavelength in DWDM systems. Integration into a network management system is not possible. Standardization of data transfer rates in FiberChannel adheres strictly to a doubling of the net bit rate, i.e. 1GFC, 2GFC, 4GFC, 8GFC, 16GFC, 32GFC. An exception to this rule is the 10GFC signal, currently the highest data transfer rate, because it for the first time allows multiplexing into the OTN by means of the so-called overclocked frame. Despite this, 8GFC is more often favored. The OTN standard also allows for this: developed solely for FiberChannel, integration is possible using GFP-T (T stands for transparent). However, a framing procedure GFP-F (F stands for framed) has to be added after this, as this is the only way to add idle frames to the payload signal in order to achieve the OTN data transfer rate.

This increases the signal delay for the transmission and it is questionable whether the transmissions in FiberChannel with extremely time-critical confirmation messages would still be within limits. The required low round trip delay times are incidentally the main reason why the Ethernet standard is unsuitable for SAN transmissions. 16GFC and 32GFC are being evaluated by the standardization committee. This further development would be a major step away from all the transmission frames standardized thus far that allow simple integration. FiberChannel would thus continue to occupy its own parallel universe in the world of telecommunications.

Measuring equipment for optical transport networks

Initially, the requirement for an end-to-end measurement does not change anything for the measuring equipment. It goes without saying that the corresponding interfaces and protocols must be addressed, such as SDH, OTN or Gigabit Ethernet. Things become much more complex when the latest generation of network elements is to be function-tested, particularly with regard to whether mapping is correctly performed and if the signaling is set and evaluated accordingly. Of course, the test instrument must also be capable of testing all the functions that are integrated into the system. To mention just one of these functions, the network management information is transmitted in the “General

Communication Channel” GCC in the ODU frame. GCC1 and GCC2 are in the ODU frame (Figure 8); GCC0 is located in the OTU frame. The tester must be able to record these transmissions over a longer period of time in order to evaluate important signaling information. Other important OTN functions here are path monitoring (PM), tandem connection monitoring (TCM) and automatic protection switching (APS).

ODU Overhead

		Column #													
		1	2	3	4	5	6	7	8	9	10	11	12	13	14
Row #	2	RES			TCM ACT	TCM6			TCM5			TCM4			FTFL
	3	TCM3			TCM2			TCM1			PM			EXP	
	4	GCC1		GCC2		APS/PCC				RES					
	4	GCC1		GCC2		APS/PCC				RES					

Figure 8: ODU overhead

All these additions to the OTN standard described therefore require measuring equipment that is also capable of testing them. Figure 9 shows the basic arrangements that must be covered by the test equipment. “Terminate” is the end-to-end test program mentioned above. OTN multiplexing is simulated functionally by means of an additional ODU layer.

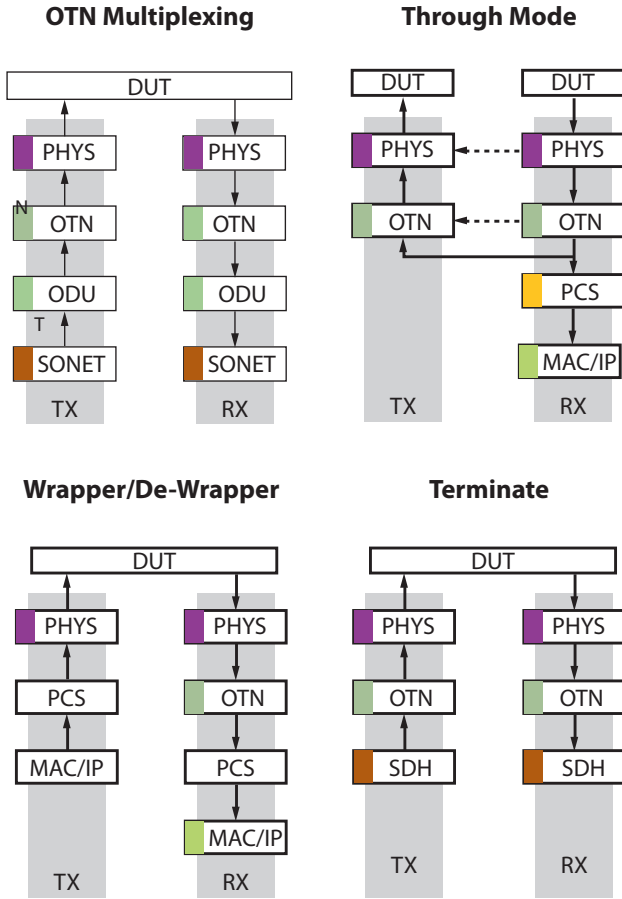

Figure 9: Test procedures for expanded transport structure acc. to ITU-T standard G.709 using test instrument ONT-506 of JDSU

The characteristic of multiplexing and demultiplexing the client signals into and out of the OTN transmission frame by the network elements is tested and verified using the wrapper/de-wrapper function. The “through mode” function takes on particular importance; this allows the OTN signal together with the payload signal on the transmission side to be looped through the measuring instrument and analyzed at the same time (non-intrusive). The signaling information in the OTN frame can be manipulated in intrusive mode so as to test the corresponding behavior of the receiving network element. The complexity of a measuring set increases significantly with the implementation of the OTN expansion and differs completely from the test functions of a simple end to end tester (Figure 10).

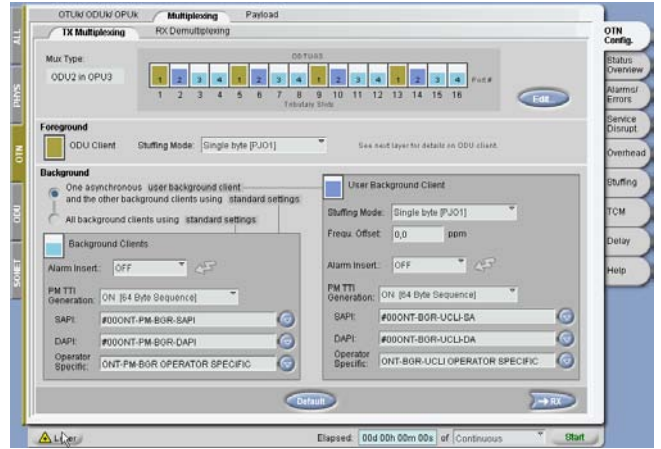

Figure 10: Multiplexing ODU2 in OPU3 using ONT-506 from JDSU



Outlook

Telecommunications transmission technology has already taken many different paths. Some of these were highly praised, yet disappeared as quickly as they appeared. Others have continued to be developed further. SDH has now been around as a transport medium for more than 20 years. However, the possibilities opened up by optical communications mean that SDH can no longer keep pace. Optical transport networks conforming to the ITU G.709 standard have stood the test in continuation of SDH and constitute a rugged transmission medium for telecommunications networks. Much is on the way, but there remain many tasks to be accomplished in practically every hierarchy level. Continuity in the integration of future data transfer rates is a must. The task set for measuring equipment is to follow these developments so that the functions of the network elements and the communications technology can be assured. For this reason, JDSU is actively participating in the relevant standardization committees in order to have a hand in shaping the telecommunications networks of the future and to be in a position to provide the corresponding test solutions in a timely manner.

Abkürzungen

DWDM	Dense Wavelength Division Multiplexing
FC	Fibre Channel
FEC	Forward Error Correction
GbE	Gigabit-Ethernet
GFP	Generic Frame Procedure
GFP-F	Generic Frame Procedure, Frame mapped
IEEE	Institute of Electrical and Electronics Engineers
ITU-T	International Telecommunication Union –Telecommunication Standardization Sector
LAN	Local Area Network
LCAS	Link Capacity Adjustment Scheme
OCh	Optical Channel
ODU	Optical Data Unit
OMS	Optical Multiplex Section
OPU	Optical Payload Unit
OTM	Optical Transport Network Module
OTN	Optical Transport Network
OTS	Optical Transport Section

TU	Optical Transport Unit
PCS	Physical Coding Sublayer
SDH	Synchronous Digital Hierarchy
Sonet	Synchronous Optical Network
STM	Synchronous Transport Module
TK	Telekommunikation
VC	Virtual Container
VCAT	Virtual Concatination

Bibliography

- [1] Kiefer/Winterling: “DWDM, SDH & Co”, VMI Industriebuch Verlag
- [2] ITU-T Document G.Sup43: “Transport of IEEE 10GBASE-R in optical transport networks (OTN)”
- [3] ITU-T Document “Recommendation G.709/Y.1331 (2003) Amendment 3 (04/09)”
- [4] T.P. Walker, AMCC: “OTN Tutorial”
- [5] Duelli/Hartmann/Menth/Hülsermann/Düser: “Performance Evaluation of IP over Cost-Optimized Optical Multilayer Networks with SRLGs”, Conference Transcript 207 of the 9th ITG Trade Conference on Photonic Networks, 2008
- [6] Winterling: 43 Gbit/s: “Die nächste Generation Telekommunikation – die nächste Generation Messtechnik”, ntz, Issue 2/2007
- [7] Ziemann: “Wann kommt Terabit-Ethernet - oder die mathematische Spielerei der Extrapolation”, ntz, Issue 5/2009
- [8] Lutz Raddatz et al: “DWDM Transmission of OTU3 (43 Gb/s) Data over 7000 km of Conventional NZ-DSF”, 7th ITG Trade Conference on Photonic Networks 2006

Test & Measurement Regional Sales

NORTH AMERICA TEL: 1 866 228 3762 FAX: +1 301 353 9216	LATIN AMERICA TEL:+1 954 688-5660 FAX: +1 954 3454668	ASIA PACIFIC TEL: +852 2892 0990 FAX: +852 2892 0770	EMEA TEL: +49 7121 86 2222 FAX: +49 7121 86 1222	WEBSITE: www.jdsu.com/test
---	--	---	---	--