

Next Generation SONET/SDH – Technologies and Applications

By Werner Habisreiteringer



Executive summary

Innovation, the lifeline to survival in the telecommunications market, has spurred the telecommunications industry to adopt next-generation SONET/SDH as the most economical and technologically feasible solution for transmitting both voice and data over carrier networks. According to Marian Stasney, a Yankee Group senior analyst, “As bandwidth demand increases or equipment becomes obsolete in metropolitan networks, service providers will be purchasing next-generation SONET/SDH equipment in order to save on initial costs, long-term expenses, power, and space.” In fact, the Yankee Group estimates that the market for next-generation SONET/SDH devices is \$2.7 billion, and with a compound annual growth rate of 34 percent, worldwide revenues are expected to reach close to \$12 billion dollars in 2006.

Designed to optimize TDM-based traffic, SONET/SDH is very robust and reliable, containing built-in mechanisms to provide 99.999 percent network availability. However, SONET/SDH rings, which are the primary connection to the metropolitan area network (MAN), are not designed to handle bursty packet data efficiently.

Additional constraints on performance are the result of the MAN’s overly complex, multiple layers of poorly integrated technologies that limit flexibility. Further compounding these difficulties is the immense quantity of data traffic generated from LANs, DSL-based broadband connections, storage area networks (SANs), and local caching by ISPs. The stress that these applications place on the infrastructure puts carriers at financial risk when they are unable to deliver services or levels of performance demanded by the marketplace.

Without enhancements to the MAN, carriers do not have the flexibility to manage bandwidth or the ability to quickly provision services and ensure network scalability and operational efficiency. However, they also realize that their economic survival depends on being able to optimize the existing SONET/SDH-based network’s transport technology without spending large amounts of money or decommissioning any of the existing infrastructure.

Next-generation SONET/SDH’s advantage over Ethernet

Next-generation SONET/SDH is an umbrella term describing a range of proprietary and standards-based developments that are built on the available SONET/SDH infrastructure. First deployed by long-distance carriers as a way to support new services such as Ethernet, Fibre Channel, ESCON, and DVB, next-generation SONET/SDH enables the delivery of high-speed, high-bandwidth data within very tight budget constraints.

Properties of the data services	Properties of SONET/SDH
Asynchronous transport	Synchronous transport
Dynamic bandwidth	Constant bandwidth
Connectionless	Connection-oriented

Ethernet’s proliferation in LANs is largely due to its simplicity and cost-effectiveness. Standard Ethernet line rates are 10/100/1000 Mb/s with 10 Gb/s contending for a significant presence in the MAN. Because Ethernet is based on a best effort principle, meaning the transfer of data is not guaranteed, there is concern that Ethernet cannot fully provide the quality of service, security, redundancy, and restoration capabilities required for both data and voice traffic. The new Ethernet standard, 10 Gigabit Ethernet, is not only 10 times faster than its predecessor, but it is designed to promote the convergence of networking technologies.

However, to send a 10 Gigabit Ethernet signal directly to a legacy SONET/SDH ADM, Ethernet line termination equipment must buffer the incoming signal and convert it into a signal supported by SONET/SDH.

Although Gigabit Ethernet provides a common frame from the desktop to the backbone, a technology that serves as a transport service for storage, raw data, and audio/video, independent of the protocol, was needed. Fibre Channel (FC) was designed to remove many performance barriers that exist in legacy LANs and channels providing scalable gigabit technology, control, self-management, and reliability at distances up to 10 K.

	Gigabit Ethernet	Fibre Channel
Applications	Data networks	SAN, audio/video, data
Line rates	1.25 Gb/s	1.06 Gb/s, 2.12 Gb/s, 10 Gb/s
Frame sizes	Variable, 0-1.5 kB	Variable, 0-2 kB
Connections oriented	No	Yes

However, when FC leaves the SAN and interacts with SONET/SDH, errors and packet loss occur. Although TCP corrects for this, delays and reduced bandwidth cause performance problems.

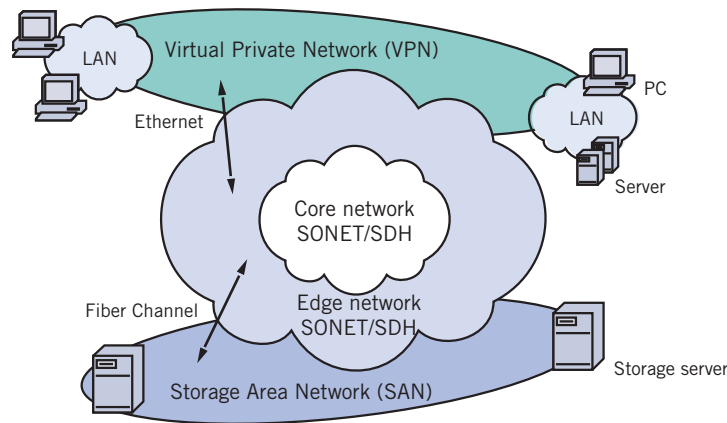

Figure 1: New services put new requirements on legacy SONET/SDH

Next-generation SONET/SDH extends the utility of the existing SONET/SDH network by leveraging existing layer 1 networking and including technologies such as virtual concatenation (VC), generic framing procedure (GFP), and the link capacity adjustment scheme (LCAS).

Components of next-generation SONET/SDH

Virtual concatenation

The traditional method of concatenation is termed “contiguous.” This means that adjacent containers are combined and transported across the SONET/SDH network as one container. Contiguous concatenation’s limitations included the necessity that all network nodes that are part of the transmission path must be able to recognize and process the concatenated container and the lack of bandwidth granularity, which makes transporting many data signals inefficient.

Virtual concatenation, as defined in standards such as ITU-T G.707/ANSI T.105, addresses the drawbacks associated with the contiguous method. Virtual concatenation maps individual containers into a virtually concatenated link. Any number of containers can be grouped together, which provides better bandwidth granularity than attained using traditional techniques. In addition, it enables network operators to adjust the transport capacity to the required customer service for greater efficiency. Because the intermediate network nodes treat each container in the link as a standard, concatenated container, only the path originating and path terminating

equipment need to recognize and process the virtually concatenated signal structure. This means that each link can take its own path through the network, which can lead to phase differences between containers arriving at the path terminating equipment, requiring the equipment to buffer delays.

Service	Transport capacity efficiency without VC	Transport capacity efficiency with VC
Ethernet (10 Mbit)	VC-3 --> 20%	VC-12-5v --> 92%
Fast Ethernet (100 Mbit)	VC-4 --> 67%	VC-12-46v --> 100%
ESCON (200 MByte)	VC-4-4c --> 33%	VC-3-4v --> 100%
Fibre Channel (1 Gbit)	VC-4-16c --> 33%	VC-4-6v --> 89%
Gigabit Ethernet (1000 Mbit)	VC-4-16c --> 42%	VC-4-7v --> 85%

Today’s transport granularities are defined by the standard line rates STM-1/4/16 and STM-64 (OC-3/12/48 and OC-192). For example, a 1 G service is currently transported via an STM-16 channel. In this case, the actual transport capacity efficiency is about 42 percent. The group VC-4-7v is a virtual concatenated group (VCG), where VC-4 defines the basic granularity and 7v defines the number of members in the group, for nearly an 85 percent gain in efficiency.

The information required for virtual concatenation is transported in the path overhead of the individual containers.

	SDH	SONET
High order path	H4	H4
Low order path	K4	Z7

The parameters required for virtual concatenation are the frame counter (MFI) and the sequence number (SQ). Because members of a VCG can travel through the network via different paths, they do not all arrive at the destination port at the same time. To eliminate this **differential delay** and guarantee the integrity of all the members in a group, a sequence number (SQ) is assigned to each member.

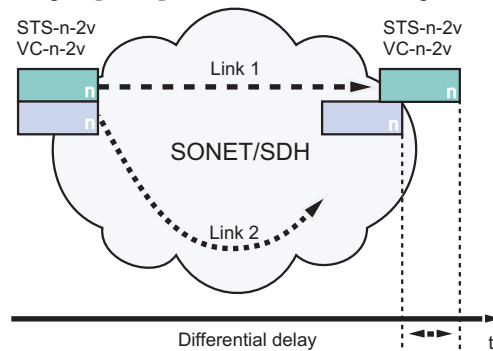

Figure 2: Differential delay caused by different ways through the network

The MFI can detect differential delays between VCG members and compensate for them up to 512 ms. The parameters describing the frame counter and sequence number are summarized in the following table.

Path	Number of frames	Sequence number
High order path	0 – 4095	0 – 255
Low order path	0 – 4095	0 – 63

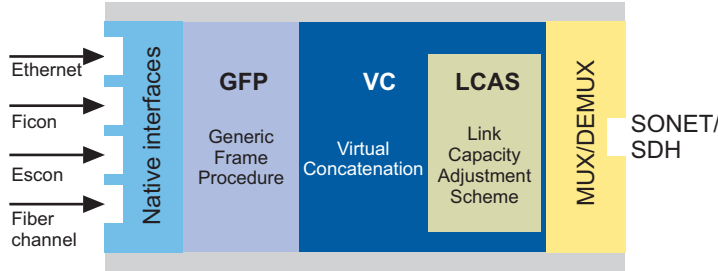

Figure 3: Overview of next-generation SONET/SDH

Generic framing procedure

Encapsulation techniques such as the generic framing procedure (GFP) must be applied to adapt asynchronous, bursty traffic and variable frame sizes before data service traffic such as IP/PPP, Ethernet MAC, Fibre Channel, ESCON, and FICON is transported over SONET/SDH networks. GFP adapts a frame-based data stream to a byte-oriented data stream by mapping the diverse services into a general-purpose frame, which is then mapped into the well-known SONET/SDH frames. This framing structure is better at detecting and correcting errors and provides greater bandwidth efficiency than traditional encapsulation procedures.

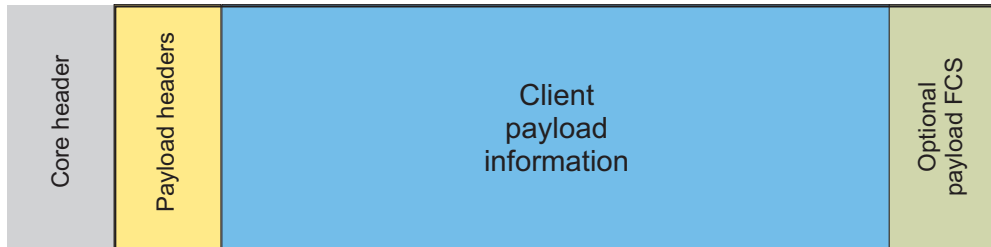

Figure 4: GFP frame

- The four parts comprising the GFP frame are the core header, payload header, actual payload area, and optional error detection field.
- Core header defines the GFP frame length and detects CRC errors
- Payload header defines the type of information transported, either management frames or client frames as well as the content of the payload
- Client payload information defines the actual transport payload
- Optional FCS detects errors
- There are currently two modes of client signal adaptation defined for GFP:
 - GFP framed (GFP-F), where one data signal frame is mapped in its entirety into one GFP frame
 - GFP transparent (GFP-T), where data signal block codes are mapped into periodic GFP frames
- GFP is defined in ITU-T G.7041/Y.1303

The mode used is dependent on the service being transported. However, to date, Ethernet is the data client signal defined for GFP-F. GFP-T maps any data client signal, but is mainly needed today to carry Fibre Channel. The services mapped via GFP-F consume the least amount of overhead to guarantee the greatest bandwidth efficiency, whereas the priority of those mapped via GFP-T is the fast, efficient transport of data.

In addition to GFP as an adaptation mechanism, there are other methods. Of these, the link access protocol (LAPS) and the high-level data link control (HDLC) are the two predominant framing mechanisms. However, GFP supports multiple services, and it has higher flexibility so that it can be used in combination with OTN and higher stability, which offers the possibility of introducing GFP multiplexing structures. Therefore, GFP is the adaptive mechanism for the future.

Mode	Description	Application
GFP-F	Service is mapped frame-by-frame into the GFP frame Minimal overhead Variable GFP frame length	Fast Ethernet, Gig Ethernet, IP, etc.
GFP-T	Service is mapped byte-by-byte into the GFP frame Optimized transfer delay Constant GFP frame length	Fibre Channel, FICON, ESCON, Ethernet, DVB, etc.

LCAS

ITU-T G.7041/Y.1305 define the LCAS protocol, which runs between two NEs that are connected at the customer interface to the traditional SONET/SDH network. Each H4/K4 byte transports a control packet, which consists of information regarding virtual concatenation and parameters of the LCAS protocol.

By determining which members of a VCG are activated and how they are used, LCAS enables the originating equipment to dynamically change the number of containers in a concatenated group in response to a real-time change in bandwidth requirement. This increase or decrease in the transport bandwidth can be accomplished without negatively influencing the service. For example, a company that is supported by a 500 Mb/s link between branches during normal business hours needs a higher bandwidth to perform updates during off hours. With LCAS, 1 Gig of additional bandwidth is automatically provisioned without any adverse impact to the service.

The following parameters in the control packet are relevant for the LCAS protocol:

- Control commands (CTRL) synchronize the source and receiver and transport information regarding the status of the individual members of a VCG
- Source identifier (GID) tells the receiver which VCG a particular member belongs to
- Resequencing acknowledgement (RS-Ack) notifies the source that the receiver received initiated changes
- Member status (MST) transfers the status of the link from the sink to the source for each individual member of the VCG (OK=0, FAIL=1).
- Error protection (CRC) detects errors and discards errored control packets for individual members of the VCG

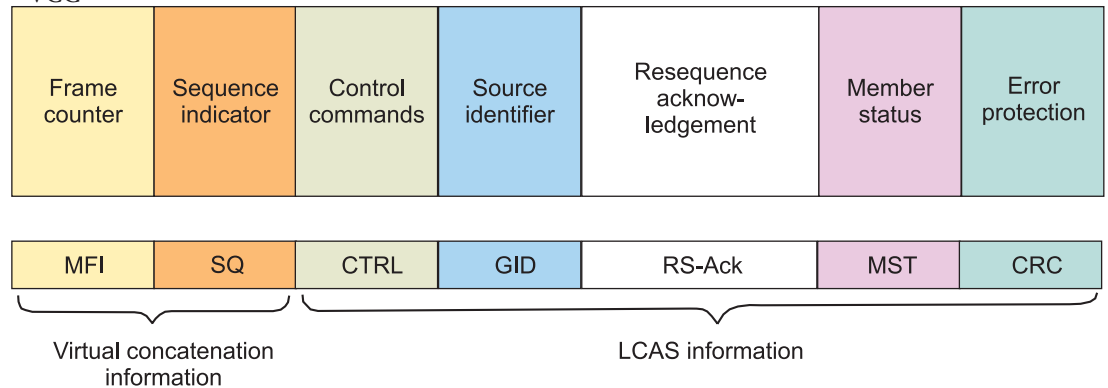

Figure 5: VC/LCAS control packet

Interworking testing—the key component in service assurance

Testing is a key component in overcoming the challenges of delivering asynchronous services over continuous synchronous SONET/SDH networks. It is not only the first step, but it is also a necessary ongoing process to guarantee that all layers, from the service layer to the GFP layer as well as VC and LCAS, function properly.

Areas to test

Service transparency

Testing on packet-oriented services such as Ethernet must be performed on all NEs, including legacy SONET/SDH and PDH interfaces between customers, the MAN, and the core network. In addition:

- Each received Ethernet frame is analyzed for errors and alarms
- Traffic profiles of network utilization are generated to indicate how new end users are behaving and to determine if traffic is constant or bursty
- Worst case analysis is performed on the mapping and demapping of a large number of short Ethernet frames or other abnormal conditions such as oversized frames

Bandwidth adaptation

To accommodate Ethernet client bandwidth demand, which has grown from 10 Mb/s to 30 Mb/s, GFP, as the adaptation layer, fills up the current available bandwidth of the transport network. When more bandwidth is needed, virtual containers are added to the VCG, which GFP automatically recognizes, triggering it to release additional bandwidth.

By testing the NEs, their ability to add and remove virtual containers is verified, and confirmation that GFP can appropriately respond to any changes is provided.

Compensation mechanism for differential delay

When the network supports virtual concatenation, the payload is split and sent via different paths through a long-haul network. Because these two paths are not the same length and contain a different number of NEs, the VCG members do not reach the termination point at the same time. Before reassembling the payload, the terminating equipment must compensate for this differential delay. However, because this process consumes computing power and memory space, it must be checked thoroughly to ensure it was implemented properly.

To prevent poor throughput, the loss of the payload, or the complete collapse of the connection, it is important to test for:

- The NE's ability to store members of a group to compensate for differential delays
- The reassembly of the members of a group to the complete VCG

Dynamic bandwidth adaptation

If LCAS is used, simulating the increased and decreased use of bandwidth by manipulating the LCAS state machine can verify if the protocol was implemented correctly. Because LCAS is not symmetrical, both its forward and backward directions need to be tested simultaneously by generating the right control commands in the control packet and monitoring the response of the NE. It is important to have the ability to perform tests with equipment that have handshake capability and can validate bandwidth adaptation without interrupting service.

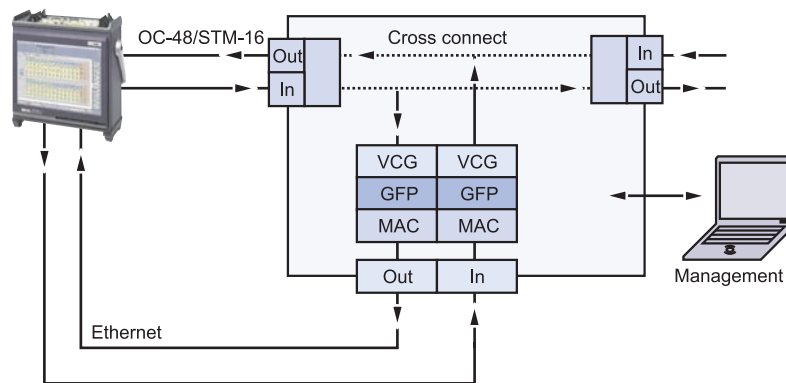

Figure 6: Interworking test using the JDSU ONT-503

Integrity of the NE's interfaces

After next-generation NEs are integrated into a legacy SONET/SDH network, they must be tested for compliance with ITU-T/ANSI/Telcordia recommendations. In particular, the tests are designed to verify the correct implementation of error and alarms reaction, trace identifiers, and path overhead content. Although today's client payload of VCGs is transported by one large congruous concatenated container that provides for overcapacity, VCGs combine a number of small virtual containers to provide individual transport capacity. Therefore, to verify compliance with ITU recommendations, all tests must be performed on each small container. In addition to the SONET/SDH interfaces, all client interfaces must be tested.

Conclusion

The biggest advantage of next-generation SONET/SDH is that it allows network operators to introduce new technology into their traditional SONET/SDH networks by replacing only the edge NEs. With this capability, both TDM and packet-oriented services are handled efficiently on the same wavelength. In addition, there is significant improvement in how SONET/SDH networks manage packet bandwidth and greater granularity while maintaining the critical functions of traditional TDM networks.

Next-generation SONET/SDH's flexibility enables network operators to either build a network using hybrid TDM/packet multiservice provisioning platforms or to provide only the underlying transmit bit stream framing.

With the telecommunications' industry in transition, the emphasis within network operations is on meeting customer demand within strict budgets. Next-generation SONET/SDH not only is cost-effective, it enhances legacy networks' capabilities and capacity to levels that surpass other options. By integrating next-generation SONET/SDH technology into legacy networks, significant gain in throughput, quality, and service availability are achieved as long as testing and monitoring are employed to verify that new and existing technology can accommodate increasing bandwidth demands.

Operators that overlook these important steps will not save money in the long term. Without constant verification that the NEs are performing appropriately, not only is service quality jeopardized, the long-term costs associated with constant service disruptions, downtime, and unnecessary maintenance prevent network operators from operating profitably or building a base of loyal customers.

Test & Measurement Regional Sales

NORTH AMERICA TEL: 1 866 228 3762 FAX: +1 301 353 9216	LATIN AMERICA TEL:+55 11 5503 3800 FAX:+55 11 5505 1598	ASIA PACIFIC TEL:+852 2892 0990 FAX:+852 2892 0770	EMEA TEL:+49 7121 86 2222 FAX:+49 7121 86 1222	WEBSITE: www.jdsu.com
---	--	---	---	--