

Practical NewGen Measurements

with ONT-503/ONT-506/ONT-512



Practical NewGen measurements

To evaluate NewGen network elements it is essential to test all particular technologies, which are integrated in these new systems. The measurements start with the physical SONET/SDH interfaces and progress to the Ethernet/MAC analysis mapped into GFP.

This document provides a practical and systematic guide for testing all relevant layers and critical functions. The procedures are based on Ethernet over the most common SONET and SDH mappings (EoS) such as STS-3c-nv and VT-1.5-nv for SONET and VC-4-nv and VC-12-nv for SDH.

Based on our practical experience with evaluating NewGen network elements we as JDSU faced several measurement challenges. To communicate this experience to our customers, we put together questions and answers, which may help identify and solve upcoming problems during practical measurements.

Contents

Practical NewGen measurements	1
Test specifications for acceptance test of NewGen network elements	2
Testing procedure example 1GigE and STM-16/VC-4-7v	3
Testing procedure example 100M Ethernet and STM-16/VC-12-48/64v	5
Testing procedure example 1GigE and OC-48/STS-3c-7v	7
Testing procedure example 100M Ethernet and OC-48/VT-1.5-64v	9
Questions and Answers	11
How can NewGen Systems be monitored in-service?	11
How do you measure the maximum differential delay (MDD) of a NewGen system?	12
What must be kept in mind with optical Ethernet links?	12
What are the possible causes of an Ethernet "Link down"?	12
What are the possible causes of an Ethernet "LPAC" (no traffic) alarm?	13
Which MAC addresses need to be set, and where?	14
How do you activate flow control for Ethernet?	15
What affects the transfer delay (latency) in Ethernet?	15
ONT family	16
ONT-503	16
ONT-506	16
ONT-512	16

Test specifications for acceptance test of NewGen network elements

The following tests have been proven on working systems – they may vary or have slightly different results dependent on the DUT (device under test) and its configuration. All tests are done with the JDSU ONT-503 with NewGen- and Ethernet modules. The table describes the testing procedures, the results and the related signal path (dotted or solid line) in the picture above.

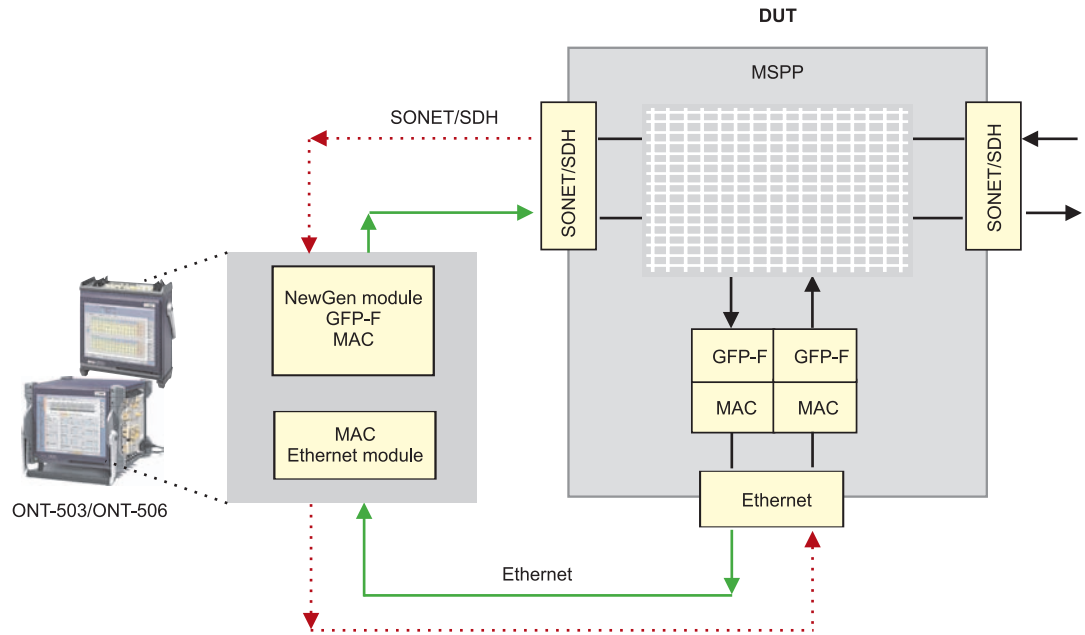

Example configuration: Please refer to this graphic for solid and dotted lines

Testing procedure example 1GigE and STM-16/VC-4-7v

	Testing procedures VC-4-nv	Results	Path
VC testing			
1	LCAS off Select members 1, 3, 5, 7, 9, 11, 13 Thruput of 1GE frame length 1500	No lost frames in SDH/MAC and Eth/MAC Eth traffic ~ 1G	Dotted & solid
2	LCAS off Select members 11, 4, 16, 3, 9, 1, 14 Thruput of 1GE frame length 1500	No lost frames in SDH/MAC and Eth/MAC Eth traffic ~ 1G	Dotted & solid
3	Asymmetric VCs: STM-16TX VC-4-7v = DUT-RX STM-16RX VC-4-3v = DUT-TX	ONT Eth RX traffic ~1GE ONT SDH/MAC RX traffic ~450M	Solid dotted
LCAS testing			
10	LCAS on Select members 1, 3, 5, 7, 9, 11, 13 Thruput of 1GE frame length 64	No lost frames in SDH/MAC and Eth/MAC Eth traffic ~ 950M	Dotted & solid
11	Remove 1 member (LCAS source DUT)	Eth traffic decreased hitless: 950M – 150M Flow control enabled – paused frames at Eth/MAC	Dotted
12	Eth traffic Eth Link to 4x 150M = 600M Remove 2 more members DUT (source)	→ Eth traffic ~550M No hit, no lost frames (dotted), no flow control, no pause frames	Dotted solid
13	Add 1 member DUT (source) Add 2 more members DUT (source)	Hitless adaptation - no lost frames	Dotted
14	Eth traffic Eth Link to 1GE	No hit, no lost frames	Dotted
15	Insert AU-AIS into member ONT (solid)	DUT responds MST FAILED ONT source command DNU Eth. traffic lost frames Bandwidth 950M– 150M ONT-SDH-RX → RDI alarm	Solid Dotted
16	Delete AU-AIS in the member ONT (solid)	ONT source and DUT sink NORM Eth. traffic back to 1G hitless ONT-SDH-RX - RDI alarm disabled	Solid Dotted
17	Asymmetric VCs with LCAS STM-16TX VC-4-7v STM-16RX VC-4-3v	ONT Eth RX traffic ~950M ONT SDH/MAC RX traffic ~450M	Dotted & solid
Differential delay testing (MDD= maximum diff.delay)			
20	LCAS on (= max. stress) Select members 1, 3, 5, 7, 9, 11, 13 Thruput of 1GE frame length 64	No lost frames in SDH/MAC and Eth/MAC Eth traffic ~ 950M	Solid
21	Set delay of 1 member to max allowed diff. delay MDD (e.g. 32 ms = 256 frames with 125 μs) – apply with direct mode (simulates APS actions)	Traffic is lost for a certain time, then resynchronized (MDD ok) If traffic stays lost → MDD spec not met	Solid
22	Set delay of all members to 0 – apply with direct mode (delay reset)	Traffic is lost for a certain time, then resynchronized	Solid
23	Set delay of 6 members to max allowed diff. delay MDD (e.g. 32 ms = 256 frames with 125 μs) – apply with direct mode	Traffic is lost for a certain time, then resynchronized (MDD ok) If traffic stays lost → MDD spec not met	Solid

	Testing procedures VC-4-nv	Results	Path
24	Set delay of all members to 0 – apply with direct mode (delay reset)	Traffic is lost for a certain time, then resynchronized	Solid
25	Set delay pointer speed to max (pointer every 4 frames) Set delay of 1 member to max allowed diff. delay MDD (e.g. 32 ms = 256 frames with 125 µs) – apply with pointer mode simulates “max. delay wander”	No lost frames – MDD spec is met	Solid
26	Set delay of all members to 0 – apply with direct mode (delay reset)	Traffic is lost for a certain time, then resynchronized	Solid
27	Increase delay of 1 member to MDD plus 10 ms – apply with pointer mode checks for the limit delay value	If the MDD exceeds the limit of the input stage - lost frames. This MDD value gives the maximum accepted DD of the system	Solid
28	Set delay of all members to 0 – apply with direct mode (delay reset)	Traffic is lost for a certain time, then resynchronized	Solid
GFP-F testing			
30	Insert client signal fail (CSF) alarm	DUT should detect CSF (sometimes not implemented)	Solid
31	Set Eth traffic to max and back-to-back → prevents error injection in GFP idle frames. Generate core, payload type and extension single header errors (correctable)	DUT no effect, traffic no effect	Solid
32	Generate core dual header errors (not correctable)	DUT → LFD (GFP out of sync) ONT-Eth/MAC → lost frames	Solid
33	Generate payload type and extension dual header errors (not correctable)	ONT-Eth/MAC → lost frames	Solid
34	Generate ONT-Eth-link disparity errors and invalid code groups (with GigE only)	Lost packets (may be GFP CSF alarm)	Dotted
Ethernet testing (interworking)			
40	Measure transfer delay ONT-Eth-MAC/link → DUT → ONT-SDH/MAC	Value DUT dependent	Dotted
41	Measure transfer delay ONT-SDH/MAC → DUT → ONT-Eth-link/MAC	Value DUT dependent	Solid
42	Thruput of 1GE frame length 64	No lost frames in SDH/MAC and Eth/MAC Eth traffic ~ 950M	Dotted & solid
43	Thruput of 1GE frame length 9900 (jumbo)	No lost frames in SDH/MAC and Eth/MAC Eth traffic ~ 1G	Dotted & solid
44	Asymmetric Ethernet: ONT-SDH/MAC = 10Mb length 9900 ONT-Eth/MAC = 1G length 64	No lost packets ONT-SDH/MAC-RX and ONT-Eth/Link-RX and DUT	Solid Dotted

Testing procedure example 100M Ethernet and STM-16/VC-12-48/64v

	Testing procedures VC-12-nv	Results	Path
VC testing			
1	LCAS off Select 64 members in AU4#1 and AU4#2 Check availability of 64 members Thruput of 100ME frame length 1500	No lost frames in SDH/MAC and Eth/MAC Eth traffic ~ 100M	Dotted & solid
2	LCAS off Select 64 members in AU4#5 and AU4#16 Check availability of 64 members Thruput of 100ME frame length 1500	No lost frames in SDH/MAC and Eth/MAC Eth traffic ~ 100M	Dotted & solid
3	LCAS off Distribute 64x VC-12 members in arbitrary position in two to four AU4s Thruput of 100ME frame length 1500	No lost frames in SDH/MAC and Eth/MAC Eth traffic ~ 100M	Dotted & solid
4	Asymmetric VCs: STM-16TX VC-4-64v = DUT-RX STM-16RX VC-4-30v = DUT-TX	ONT Eth RX traffic ~100M ONT SDH/MAC RX traffic ~65M	Solid dotted
LCAS testing			
10	LCAS on Select 48 members Thruput of 100ME frame length 64	No lost frames in SDH/MAC and Eth/MAC Eth traffic ~ 93M	Dotted & solid
11	Remove 1 member (LCAS source DUT)	Eth traffic decreased hitless: 93M – 2M ~ 91M Flow control enabled – paused frames at Eth/MAC	Dotted
12	Eth traffic Eth Link to ~87M Remove 2 more members DUT (source)	→ Eth traffic ~ 87M No hit , no lost frames (dotted), no flow control, no pause frames	Dotted solid
13	Add 1 member DUT (source) Add 2 more members DUT (source)	Hitless adaptation – no lost frames	Dotted
14	Eth traffic Eth Link to 100ME	No hit , no lost frames	Dotted
15	Insert AU-AIS into member ONT (solid)	DUT responds MST FAILED ONT source command DNU Eth. traffic lost frames Bandwidth 93M– 2M	Solid
		ONT-SDH-RX → RDI alarm	Dotted
16	Delete AU-AIS in the member ONT (solid)	ONT source and DUT sink NORM Eth. traffic back to 93M hitless ONT-SDH-RX – RDI alarm disabled	Solid Dotted
17	Asymmetric with LCAS: STM-16TX VC-4-64v = DUT-RX STM-16RX VC-4-30v = DUT-TX	ONT Eth RX traffic ~100M ONT SDH/MAC RX traffic ~65M	Dotted & solid
Differential delay testing (MDD= maximum diff.delay)			
20	LCAS on (= max.stress) 64 members Thruput of 100ME frame length 64	No lost frames in SDH/MAC and Eth/MAC Eth traffic ~ 100M	Solid
21	Set delay of 1 member to max allowed diff. delay MDD (e.g. 32 ms = 64 frames with 500 μs) – apply with direct mode (simulates APS actions)	Traffic is lost for a certain time, then resynchronized (MDD ok) If traffic stays lost → MDD spec not met	Solid
22	Set delay of all members to 0 – apply with direct mode (delay reset)	Traffic is lost for a certain time, then resynchronized	Solid
23	Set delay of 6 members to max allowed diff. delay MDD (e.g. 32 ms = 64 frames with 500 μs) – apply with direct mode	Traffic is lost for a certain time, then resynchronized (MDD ok) If traffic stays lost → MDD spec not met	Solid

	Testing procedures VC-12-nv	Results	Path
24	Set delay of all members to 0 – apply with direct mode (delay reset)	Traffic is lost for a certain time, then resynchronized	Solid
25	Set delay pointer speed to max (pointer every 4 frames) Set delay of 1 member to max allowed diff. delay MDD (e.g. 32 ms = 64 frames with 500 μ s) – apply with pointer mode simulates “max. delay wander”	No lost frames – MDD spec is met	Solid
26	Set delay of all members to 0 – apply with direct mode (delay reset)	Traffic is lost for a certain time, then resynchronized	Solid
27	Increase delay of 1 member MDD plus 10 ms – apply with pointer mode checks for the limit delay value	If the MDD exceeds the limit of the input stage - lost frames. This MDD value gives the maximum accepted DD of the system	Solid
28	Set delay of all members to 0 – apply with direct mode (delay reset)	Traffic is lost for a certain time, then resynchronized	Solid
GFP-F testing			
30	Insert client signal fail (CSF) alarm	DUT should detect CSF (sometimes it's not implemented)	Solid
31	Set Eth traffic to max and back-to-back → prevents error injection in GFP idle frames. Generate core, payload type and extension single header errors (correctable)	DUT no effect, traffic no effect	Solid
32	Generate core dual header errors (not correctable)	DUT → LFD (GFP out of sync) ONT-Eth/MAC → lost frames	Solid
33	Generate payload type and extension dual header errors (not correctable)	ONT-Eth/MAC → lost frames	Solid
Ethernet testing (interworking)			
40	Measure transfer delay ONT-Eth-MAC/link → DUT → ONT-SDH/MAC	Value DUT dependent	Dotted
41	Measure transfer delay ONT-SDH/MAC → DUT → ONT-Eth-link/MAC	Value DUT dependent	Solid
42	Thruput of 100ME frame length 64	No lost frames in SDH/MAC and Eth/MAC Eth traffic ~ 100M	Dotted & solid
43	Thruput of 100ME frame length 9900 (jumbo)	No lost frames in SDH/MAC and Eth/MAC Eth traffic ~ 100M	Dotted & solid
44	Asymmetric Ethernet: ONT-SDH/MAC = 10Mb length 9900 ONT-Eth/MAC = 100M length 64	No lost packets ONT-SDH/MAC-RX and ONT-Eth/Link-RX and DUT	Solid Dotted

Testing procedure example 1GigE and OC-48/STS-3c-7v

	Testing procedures STS-3c-nv	Results	Path
VC testing			
1	LCAS off Select members 1, 3, 5, 7, 9, 11, 13 Thruput of 1GE frame length 1500	No lost frames in SONET/MAC and Eth/MAC Eth traffic ~ 1G	Dotted & solid
2	LCAS off Select members 11, 4, 16, 3, 9, 1, 14 Thruput of 1GE frame length 1500	No lost frames in SONET/MAC and Eth/MAC Eth traffic ~ 1G	Dotted & solid
3	Asymmetric VCs: OC-48TX STS-3c-7v = DUT-RX OC-48RX STS-3c-3v = DUT-TX	ONT Eth RX traffic ~1GE ONT SONET/MAC RX traffic ~450M	Solid dotted
LCAS testing			
10	LCAS on Select members 1, 3, 5, 7, 9, 11, 13 Thruput of 1GE frame length 64	No lost frames in SONET/MAC and Eth/MAC Eth traffic ~ 950M	Dotted & solid
11	Remove 1 member (LCAS source DUT)	Eth traffic decreased hitless: 950M – 150M Flow control enabled – paused frames at Eth/MAC	Dotted
12	Eth traffic Eth Link to 4x 150M = 600M Remove 2 more members DUT (source)	→ Eth traffic ~550M No hit , no lost frames (dotted), no flow control, no pause frames	Dotted solid
13	Add 1 member DUT (source) Add 2 more members DUT (source)	Hitless adaptation - no lost frames	Dotted
14	Eth traffic Eth Link to 1GE	No hit , no lost frames	Dotted
15	Insert AIS-P into member ONT (solid)	DUT responds MST FAILED ONT source command DNU Eth. traffic lost frames Bandwidth 950M– 150M ONT-SONET-RX → RDI alarm	Solid Dotted
16	Delete AIS-P in the member ONT (solid)	ONT source and DUT sink NORM Eth.traffic back to 950M hitless ONT-SONET-RX - RDI alarm disabled	Solid Dotted
17	Asymmetric VCs with LCAS OC-48TX STS-3c-7v OC-48RX STS-3c-3v	ONT Eth RX traffic ~950M ONT SONET/MAC RX traffic ~450M	Dotted & solid
Differential delay testing (MDD = maximum diff. delay)			
20	LCAS on (= max. stress) Select members 1, 3, 5, 7, 9, 11, 13 Thruput of 1GE frame length 64	No lost frames in SONET/MAC and Eth/MAC Eth traffic ~ 950M	Solid
21	Set delay of 1 member to max allowed diff. delay MDD (e.g. 32 ms = 256 frames with 125 μs) – apply with direct mode (simulates APS actions)	Traffic is lost for a certain time, then resynchronized (MDD ok) If traffic stays lost → MDD spec not met	Solid
22	Set delay of all members to 0 – apply with direct mode (delay reset)	Traffic is lost for a certain time, then resynchronized	Solid
23	Set delay of 6 members to max allowed diff. delay MDD (e.g. 32 ms = 256 frames with 125 μs) – apply with direct mode	Traffic is lost for a certain time, then resynchronized (MDD ok) If traffic stays lost → MDD spec not met	Solid
24	Set delay of all members to 0 – apply with direct mode (delay reset)	Traffic is lost for a certain time, then resynchronized	Solid

	Testing procedures STS-3c-nv	Results	Path
25	Set delay pointer speed to max (pointer every 4 frames) Set delay of 1 member to max allowed diff. delay MDD (e.g. 32 ms = 256 frames with 125 μs) – apply with pointer mode simulates “max. delay wander”	No lost frames – MDD spec is met	Solid
26	Set delay of all members to 0 – apply with direct mode (delay reset)	Traffic is lost for a certain time, then resynchronized	Solid
27	Increase delay of 1 member to MDD plus 10 ms – apply with pointer mode checks for the limit delay value	If the MDD exceeds the limit of the input stage – lost frames. This MDD value gives the maximum accepted DD of the system	Solid
28	Set delay of all members to 0 – apply with direct mode (delay reset)	Traffic is lost for a certain time, then resynchronized	Solid
GFP-F testing			
30	Insert client signal fail (CSF) alarm	DUT should detect CSF (sometimes it’s not implemented)	Solid
31	Set Eth traffic to max and back-to-back → prevents error injection in GFP idle frames. Generate core, payload type and extension single header errors (correctable)	DUT no effect, traffic no effect	Solid
32	Generate core dual header errors (not correctable)	DUT → LFD (GFP out of sync) ONT-Eth/MAC → lost frames	Solid
33	Generate payload type and extension dual header errors (not correctable)	ONT-Eth/MAC → lost frames	Solid
34	Generate ONT-Eth-link disparity errors and invalid code groups (with GigE only)	Lost packets (may be GFP CSF alarm)	Dotted
Ethernet testing (interworking)			
40	Measure transfer delay ONT-Eth-MAC/link → DUT → ONT-SONET/MAC	Value DUT dependent	Dotted
41	Measure transfer delay ONT-SONET/MAC → DUT → ONT-Eth-link/MAC	Value DUT dependent	Solid
42	Thruput of 1GE frame length 64	No lost frames in SONET/MAC and Eth/MAC Eth traffic ~ 950M	Dotted & solid
43	Thruput of 1GE frame length 9900 (jumbo)	No lost frames in SONET/MAC and Eth/MAC Eth traffic ~ 1G	Dotted & solid
44	Asymmetric Ethernet: ONT-SONET/MAC = 10Mb length 9900 ONT-Eth/MAC = 1G length 64	No lost packets ONT-SONET/MAC-RX and ONT-Eth/Link-RX and DUT	Solid Dotted

Testing procedure example 100M Ethernet and OC-48/VT-1.5-64v

	Testing procedures VT-1.5-nv	Results	Path
VC testing			
1	LCAS off Select 64 members in STS1#1, #2, #3 Check availability of 64 members Thruput of 100ME frame length 1500	No lost frames in SONET/MAC and Eth/MAC Eth traffic ~ 100M	Dotted & solid
2	LCAS off Select 64 members in STS1#5, #11, #45 Check availability of 64 members Thruput of 100ME frame length 1500	No lost frames in SONET/MAC and Eth/MAC Eth traffic ~ 100M	Dotted & solid
3	LCAS off Distribute 64x VT-1.5 members in arbitrary position in 1 to 12 STS-1s Thruput of 100ME frame length 1500	No lost frames in SONET/MAC and Eth/MAC Eth traffic ~ 100M	Dotted & solid
4	Asymmetric VCs: OC-48TX VT-1.5-64v = DUT-RX OC-48RX VT-1.5-31v = DUT-TX	ONT Eth RX traffic ~100M ONT SONET/MAC RX traffic ~50M	Solid dotted
LCAS testing			
10	LCAS on Select 64 members Thruput of 100ME frame length 64	No lost frames in SONET/MAC and Eth/MAC Eth traffic ~ 91M	Dotted & solid
11	Remove 1 member (LCAS source DUT)	Eth traffic decreased hitless: 91M – 1.5M ~ 89.5M Flow control enabled – paused frames at Eth/MAC	Dotted
12	Eth traffic Eth Link to ~86.5M Remove 2 more members DUT (source)	→ Eth traffic ~ 86.5M No hit , no lost frames (dotted), no flow control, no pause frames	Dotted solid
13	Add 1 member DUT (source) Add 2 more members DUT (source)	Hitless adaptation – no lost frames	Dotted
14	Eth traffic Eth Link to 100ME	No hit , no lost frames	Dotted
15	Insert AIS-V into member ONT (solid)	DUT responds MST FAILED ONT source command DNU Eth. traffic lost frames Bandwidth 91M– 1.5M ONT-SONET-RX → RDI alarm	Solid Dotted
16	Delete AIS-V in the member ONT (solid)	ONT source and DUT sink NORM Eth. traffic back to 91M hitless ONT-SONET-RX – RDI alarm disabled	Solid Dotted
17	Asymmetric with LCAS: OC-48TX VT-1.5-64v = DUT-RX OC-48RX VT-1.5-31v = DUT-TX	ONT Eth RX traffic ~100M ONT SONET/MAC RX traffic ~50M	Dotted & solid
Differential delay testing (MDD = maximum diff. delay)			
20	LCAS on (= max. stress) 64 members Thruput of 100ME frame length 64	No lost frames in SONET/MAC and Eth/MAC Eth traffic ~ 91M	Solid

	Testing procedures VT-1.5-nv	Results	Path
21	Set delay of 1 member to max allowed diff. delay MDD (e.g. 32 ms = 64 frames with 500 μs) – apply with direct mode (simulates APS actions)	Traffic is lost for a certain time, then resynchronized (MDD ok) If traffic stays lost → MDD spec not met	Solid
22	Set delay of all members to 0 – apply with direct mode (delay reset)	Traffic is lost for a certain time, then resynchronized	Solid
23	Set delay of 6 members to max allowed diff. delay MDD (e.g. 32 ms = 64 frames with 500 μs) – apply with direct mode	Traffic is lost for a certain time, then resynchronized (MDD ok) If traffic stays lost → MDD spec not met	Solid
24	Set delay of all members to 0 – apply with direct mode (delay reset)	Traffic is lost for a certain time, then resynchronized	Solid
25	Set delay pointer speed to max (pointer every 4 frames) Set delay of 1 member to max allowed diff. delay MDD (e.g. 32 ms = 64 frames with 500 μs) – apply with pointer mode simulates “max. delay wander”	No lost frames – MDD spec is met	Solid
26	Set delay of all members to 0 – apply with direct mode (delay reset)	Traffic is lost for a certain time, then resynchronized	Solid
27	Increase delay of 1 member to MDD plus 10 ms – apply with pointer mode checks for the limit delay value	If the MDD exceeds the limit of the input stage - lost frames. This MDD value gives the maximum accepted DD of the system	Solid
28	Set delay of all members to 0 – apply with direct mode (delay reset)	Traffic is lost for a certain time, then resynchronized	Solid
GFP-F testing			
30	Insert client signal fail (CSF) alarm	DUT should detect CSF (sometimes it’s not implemented)	Solid
31	Set Eth traffic to max and back-to-back → prevents error injection in GFP idle frames. Generate core, payload type and extension single header errors (correctable)	DUT no effect, traffic no effect	Solid
32	Generate core dual header errors (not correctable)	DUT → LFD (GFP out of sync) ONT-Eth/MAC → lost frames	Solid
33	Generate payload type and extension dual header errors (not correctable)	ONT-Eth/MAC → lost frames	Solid
Ethernet testing (interworking)			
40	Measure transfer delay ONT-Eth-MAC/link → DUT → ONT-SONET/MAC	Value DUT dependent	Dotted
41	Measure transfer delay ONT-SONET/MAC → DUT → ONT-Eth-link/MAC	Value DUT dependent	Solid
42	Thruput of 100ME frame length 64	No lost frames in SONET/MAC and Eth/MAC Eth traffic ~ 91M	Dotted & solid
43	Thruput of 100ME frame length 9900 (jumbo)	No lost frames in SONET/MAC and Eth/MAC Eth traffic ~ 100M	Dotted & solid
44	Asymmetric Ethernet: ONT-SONET/MAC = 10Mb length 9900 ONT-Eth/MAC = 100M length 64	No lost packets ONT-SONET/MAC-RX and ONT-Eth/Link-RX and DUT	Solid Dotted

Questions and Answers

During the evaluation of NewGen systems questions arise concerning measurement details and methodology. In addition there are questions about the configuration of network elements, the ONT-503 and physical connection of test unit and device under test (DUT) that must be addressed.

Subsequently, you will find the most important questions and answers to each item.

How can NewGen systems be monitored in-service?

- a) Fit a power splitter. Disadvantage: Only the members of a VCG that is present on this particular fiber can be measured. Members transmitted by another route (split routing) cannot be monitored. This can be seen with LCAS-sink – the missing members are indicated as “idle” in the graphic.
- b) Some network elements provide a “Drop & Continue” (broadcast) function. See figure below. Here, all the members received are mapped into one signal, e.g. STM-16/OC-48, without compensating for the differential delay.

The entire VCG can be measured in this way (only RX used in the ONT-503).

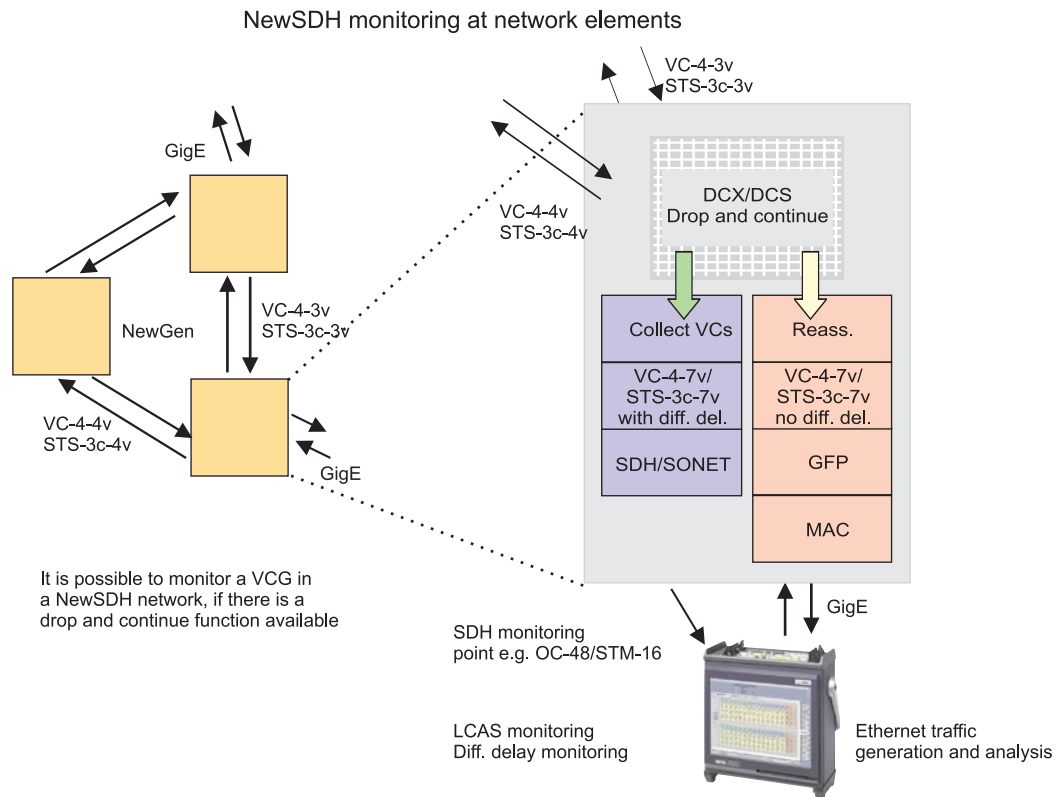

The major functions can be monitored (one direction) using both these methods:

- LCAS (switch all ONT-503 sinks to “add all”)
- Differential and maximum differential delay of all members
- GFP overhead bytes, frame types, errors, bandwidth, utilization
- Full Ethernet/MAC analysis if the traffic originated from the ONT-503
- Partial Ethernet/MAC analysis under ONT-503 “live traffic” setup

How do you measure the maximum differential delay (MDD) of a NewGen system?

Receivers in NewGen network elements operate correctly up to a maximum tolerable differential delay.

The reassembler reaches its limit when this delay occurs and so generates errors.

To test this, a NewGen signal is transmitted from the ONT-503 and its receiver analyzes Ethernet/MAC in NewSDH. The transfer delay display for the MAC layer corresponds to the differential delay value of the system (at constant full load and minimum frame length).

Checking MDD by incrementing from a small delay value

- 1 Set the TX delay for all members to 0 (direct mode)
- 2 Start the measurement. The current value at the Ethernet port is shown under transfer delay “current value”. This corresponds to the system delay (VCG + MAC)
- 3 Set the delay value of one member to MDD plus a delta value (Example: Quoted MDD = 30 ms → suitable setting = 40 ms). Start the DD with pointer mode with a slow pointer rate (e.g. 80 frames).
- 4 When MDD is reached, the Ethernet port no longer receives valid MAC test traffic. The “current value” is marked with an asterisk and the “absolute value” is frozen. This “absolute value” is a direct measure for the MDD of the system.

What must be kept in mind with optical Ethernet links?

A connection often cannot be established if the fiber link is not correctly implemented. Some Ethernet boards are, however, so robust that a link can be made or an unstable link operates even if the wavelength and/or the fiber type is incorrect.

The following should be checked if no link or only an unstable link can be made:

a) Which SFP is used:

- SX-SFP (short reach 850 nm) or LX-SFP (long reach 1310 nm). The same type must be used for the ONT-503 as for the DUT.

b) If the SFP is established, the fiber type must match it:

- Multi-mode for SX-SFP, single mode for LX-SFP.
If the distance is very short (a few meters) transmission can (!) take place regardless of the fiber type. The “Config-Interface-SFPInfo” window of the ONT-503 indicates the type of SFP that is connected.

What are the possible causes of an Ethernet “Link down”?

“Link down” means that the link cannot be set up or maintained in a stable manner. If auto-negotiation is activated, the cause can also lie in the return path, i.e. with the link partner receiver.

The following are possible causes in optical Ethernet systems:

- Optical signal missing or insufficient, e.g. if the SFPs differ or the wrong fiber type is used. This may also be the case even without an active LOS depending on the SFP.
- Bit error rate on the link is too high, so the receiver cannot synchronize.
- Auto-negotiation is off for one link partner and on for the other.
- For activated auto-negotiation only: the link partner has an RX problem (similar to 1 or 2)
- Check the possibility with the ONT-503 (auto-negotiation on for DUT and ONT)
Restart auto-negotiation on the ONT: ONT displays the link partner’s capabilities.

Hint: The link must be established despite mismatching auto-negotiation parameters if it conforms to IEEE 802.3.

What are the possible causes of an Ethernet “LPAC” (no test traffic) alarm?

LPAC (loss of performance assessment capability) means that the receiver cannot synchronize to any interpretable Ethernet test frame stream. LPAC is activated when no interpretable test traffic has been received for 10 seconds.

Where should you look for the possible causes of LPAC?

a) If it appears in the Ethernet/MAC module (Ethernet phy):

- The link must be ok, otherwise “no link” (higher priority) would be activated too.

b) If it appears in the Ethernet/MAC (Ethernet phy) module or the NewGen (SONET/SDH phy) module:

- Is traffic actually present?

Check “RX statistics-link/MAC” page: Various traffic types are counted

If not: Are the ONT and DUT addresses correct?

If yes: is “interpretable” traffic present?

Check “RX statistics-filtered” page: Traffic is interpreted

If not:

- Are the MAC addresses for SDH/MAC and Eth/MAC set correctly?
- Is a VLAN address expected (are the VLAN on/off settings different for the ONT and the DUT)?
- Is the Ethernet traffic generator set to “on” on the source side?

Which MAC addresses need to be set, and where?

Generally, the same addresses (RX and TX) cannot be used if there is an Ethernet switch in the DUT. The switch requires different addresses. The figure below shows a simple possibility that uses two addresses, each of which is entered “crosswise”.

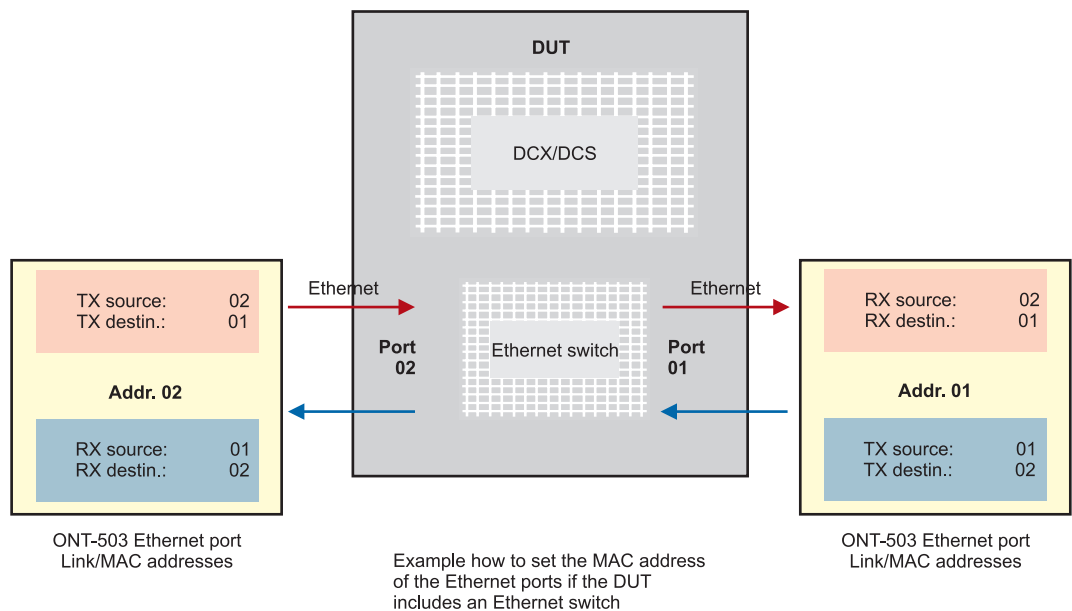
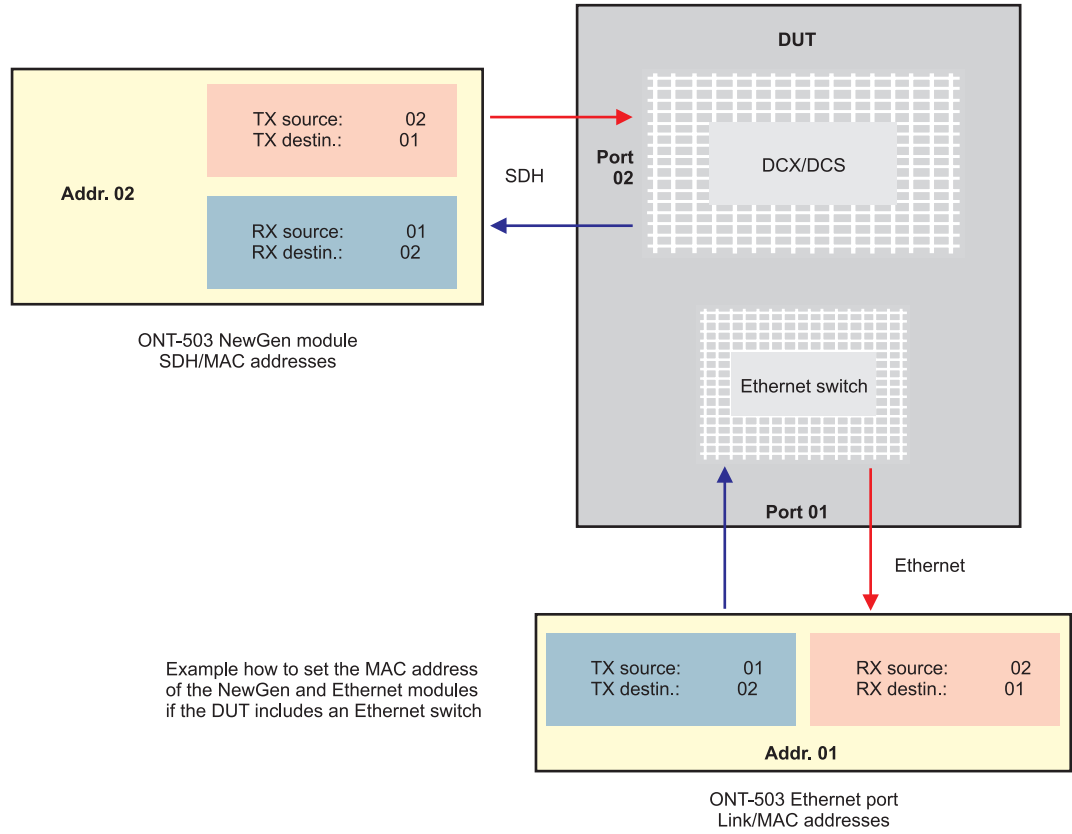

How do you activate flow control for Ethernet?

The ONT-503 always evaluates the received flow control frames (PAUSE frame count and quanta). The generator reacts to the PAUSE frames and slows down the Ethernet traffic so that no frames are lost. The generator must be set to respond to PAUSE frames by activating this function. Flow control is effective regardless of whether auto-negotiation is switched on or off.

- 1 Flow control on the Ethernet board:
Activate on the “config MAC” page. The PAUSE quanta indicates how strongly the generator reacts to each PAUSE frame.
- 2 Flow control in the MAC layer on the NewGen board
Activate on the “config MAC” page. The strength of the quanta reaction increases as the bit rate decreases (IEEE 802.3)
- 3 Flow control and auto-negotiation
The behavior of the ONT regarding flow control is independent of the settings for the auto-negotiation parameters and of the results.

The flow control parameters in auto-negotiation serve to control the DUT. Whether the DUT may transmit PAUSE frames or not is determined in this way.

If PAUSE frames are allowed, it is best to select “both” (this includes symmetric and asymmetric operation).

What affects the transfer delay (latency) in Ethernet?

Latency is the delay from one point in the network to another (one way round trip). The generator and receiver are in different testers and need to be synchronized to perform a measurement. Transfer delay (round trip) is the delay from one point in the network back to the same point via the network. Here the generator and receiver are in the same tester. Transfer delay is discussed below.

The Ethernet transfer delay (and therefore also the latency) depends on the following in NewGen/Ethernet Systems

- Differential delay of the VCG members
- Ethernet switch function
- Ethernet frame length
- Ethernet load

If the individual members of a VCG arrive at the receiver at different times, they are buffered until all the members have been received. This increases the delay of the mapped Ethernet packets.

Depending on how the Ethernet switch works, delayed packets are handled differently. The transfer delay is not dependent on the frame length for “cut through” switching, but it most definitely is for “store & forward” switching. The delay is caused by buffering the incoming packets (e.g. increasing the frame length results in an increased delay). Burst traffic is a further influence which is dependent on the “burst peak rate”, the VCG bandwidth, and how the switch behaves.

All measurements described above can be done with any member of the ONT family.

Related products



ONT-503 Optical Network Tester

The versatile ONT-503 allows to integrate all modules available for the ONT-5xx family. Its form-factor and the breadth of demanding test applications for e.g. 40/43G, Carrier Ethernet and Multichannel makes it the test set of choice for system verification groups and early deployers at Network Manufacturers' as well as Providers' companies.



ONT-506 Optical Network Tester

Desktop solution for testing of design and conformance of Next Generation transport networks. SDH, SONET, Multi-channel, OTN, Jitter, NewGen, Ethernet. Multiple users can run multiple applications simultaneously and independently. Linux operating system. High resolution 15" colored touch-screen, 6 slots.

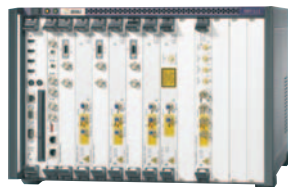

ONT-512 Optical Network Tester

Rack-mount solution for testing of design and conformance of Next Generation transport networks. Same applications as ONT-506. Easy integration into automated environments with Linux operating system and Tcl/Tk and LabWindows libraries. Built-in controller, 12 slots.

Test & Measurement Regional Sales

<p>NORTH AMERICA TEL: 1 866 228 3762 FAX: +1 301 353 9216</p>	<p>LATIN AMERICA TEL:+55 11 5503 3800 FAX:+55 11 5505 1598</p>	<p>ASIA PACIFIC TEL:+852 2892 0990 FAX:+852 2892 0770</p>	<p>EMEA TEL:+49 7121 86 2222 FAX:+49 7121 86 1222</p>	<p>WEBSITE: www.jdsu.com</p>
--	---	--	--	---