

NetComplete® Home Performance Management (PM)

by Jean Schmitt

Introduction

Delivering quadruple-play (voice, video, data, and wireless) services is an enormous technical, operational, and business challenge for today's service providers. To attract new customers as well as reduce customer churn, service providers must be able to offer quadruple-play services with the best user experience possible at a competitive price point. This whitepaper provides an overview of the following:

1. The home networking environment, required for quadruple-play service delivery.
2. The challenges that service providers face delivering user-centric quadruple-play services.
3. How the JDSU NetComplete Service Assurance Solution solves these challenges and provides effective and efficient management of the customer experience to ensure success in today's market. [1]

Home Networking Primer

This section provides an overview of the home networking environment along with common networking technologies and networking equipment such as the residential gateway (RG) and set top box (STB).

Common Home Networking Technologies

Home networking technologies are supposed to provide throughputs of tens of megabits per second (Mbps) with low latency and low packet loss throughout the entire home environment. Table 1 below lists these major technologies along with the "pros and cons" of each.

	10/100 Mbps Ethernet	PLT Powerline Technology	HomePNA 3.0	HomePNA 3.1 Coax (Home cabling)	Wireless systems (Over cable)	MoCA (Multi-media)	USB	Bluetooth	DECT
Pros	Cheap Dominant LAN technology Payload ~ 100 Mbps	New wire not required (Re-use the electricity distribution system)	Re-use phone extension cabling Less potential for transmission problems than PLT HPNA 3.0 claims a bit rate of 200 Mbps	Up to 320 Mbps while retaining the 3.0 QoS capabilities Solves some issues with the coexistence of VDSL 2 & ADSL, POTS & ISDN on the same medium	No wire required 802.11b/g: Good coverage 802.11g: Higher rates than 802.11b 802.a/h: Provides higher rates 802.11n: Increased future potential	Re-use Cable TV coax High bandwidth transmission medium	Plug and Play Very good interoperability	No wire required	No wire required Standard for cordless communications Widely adopted The upcoming New DECT standard will include real-time Increased support
Cons	Must install new wiring	Potential transmission problems Payload < 10 Mbps (Higher rate systems still proprietary) Interoperability issues High latency	Arbitrary multipoint topology Fewer phone sockets than power outlets in most of houses Limited market success to date	Insufficient infrastructure coverage within the home	802.11b/g: Not for IPTV 802.a/h: Reduced coverage Shared medium Need QoS to support streaming applications	Most of the available spectrum on the cable is already used for broadcast TV and cable modems	Peripheral attachment technology Not a home network technology Very short reach Very strict master-slave connectivity	Short reach Low-bit rate wireless system	For the time being, a DECT interface is only considered for the RG to directly support a VoIP service using the installed base of cordless phones

Table 1: Major Home Network Technologies

Residential Gateway

RG, as the Broadband Forum [2] calls it, or Home Gateway (HG), as the Home Gateway Initiative (HGI) [3] refers to it, enables connections (including, for example, broadband connection provisioning and management, and software maintenance) to several services via various service edge nodes. Figure 1 illustrates the positioning of the RG.

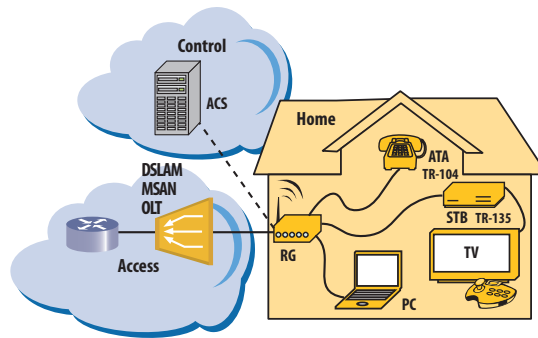

Figure 1: Remote Gateway Positioning

The RG is, in most cases, a routed model in which a built-in Dynamic Host Configuration Protocol (DHCP)¹ server assigns private Internet Protocol (IP) addresses. Connectivity for services such as Internet, voice, and video is realized through built-in network address translation (NAT)².

Some applications, such as virtual private networks (VPNs) may need NAT pass-through in the RG to work properly across the NAT.

The Broadband Forum defines technical reports (TRs) and working texts (WTs) that are related to home management. Within these, the key specification is TR-069 [4].

- The auto configuration server (ACS)³ as defined by the Broadband Forum, or the Remote Management System (RMS) as defined by the HGI, is TR-069 capable and provides a TR-069 interface and data model to remotely control and configure the RG and other TR-069-enabled devices located in the Home Network (HN). Figure 2 provides an example of the TR-069 management architecture.

¹DHCP : A set of rules used by communications devices such as computers, routers, or network adapters that lets devices request and obtain an IP address from a server, which has a list of addresses available for assignment.

²NAT: A process that involves re-writing the source and/or destination address of IP packets as they pass through a router or firewall. Most systems using NAT do so to enable multiple hosts on a private network access to the Internet using a single public IP address.

³ACS: For example, a TR-069 ACS provides the main connection between customer premises equipment (CPE) that is to be provisioned and Operational Support System (OSS) architectures.

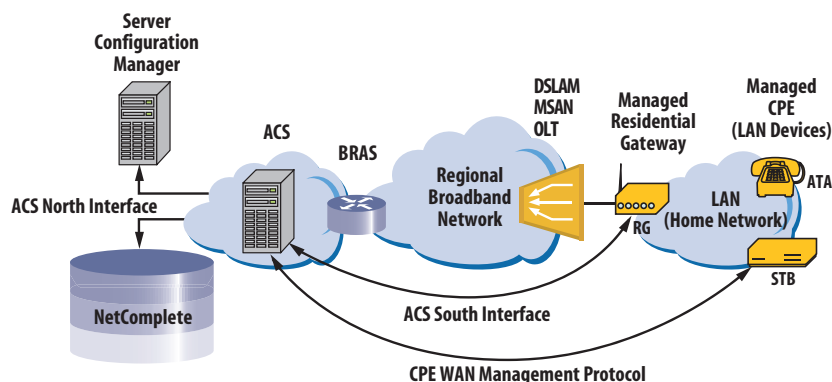

Figure 2: TR-069 Management Architecture

The Broadband Forum has defined a suite of TR-069-related standards for home management.

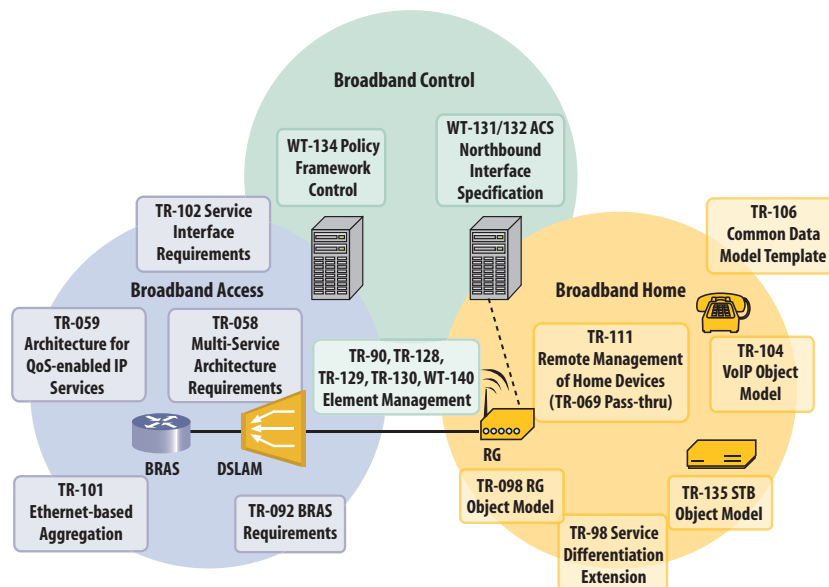

Figure 3: Broadband Forum Main Standards for Broadband Access, Control, and Home

The Broadband Forum TR-098 defines the RG object model. The major management functions it covers are:

- Device management
- Quality of Service (QoS) management
- Security management
- Configuration management
- Firmware upgrades management
- Performance monitoring
- Diagnostics and troubleshooting
- Local management application

Performance Management: As defined by the Broadband Forum, the TR-069 management protocol provides support to allow the ACS to use and monitor CPE status and performance statistics. The TR-069 management protocol also defines a set of conditions under which a CPE should actively or passively notify the ACS of changes.

Diagnostics: In addition, the TR-069 management protocol provides CPE statistics collection via the ACS to support diagnostics, connectivity, or service issues.

Figure 4 illustrates the TR-098 object models with *stats related to performance* highlighted with a red rectangle. *Diagnostic capabilities* are highlighted with orange rectangles.

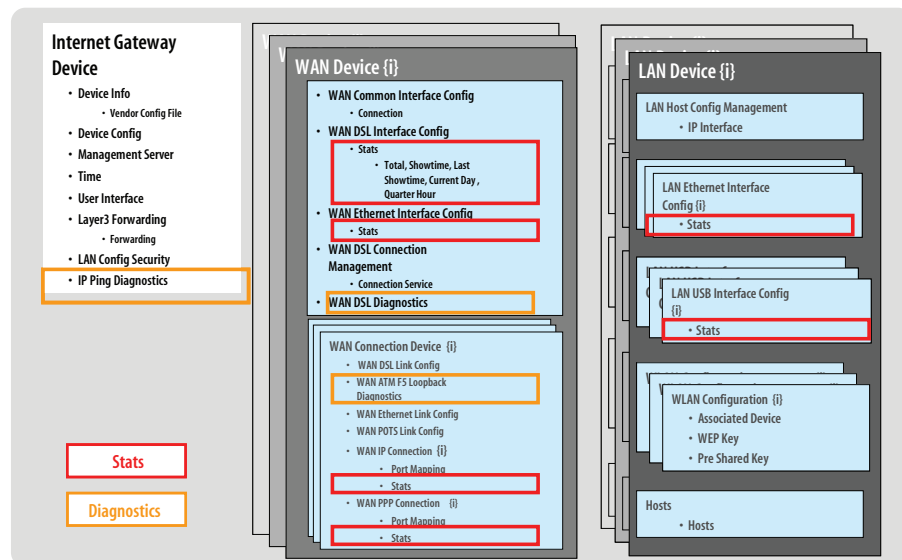

Figure 4: TR-098 Remote Gateway Object

RG with Voice Delivery Capability

One method of delivering voice over IP (VoIP) services to the residence is to deploy a RG with session initiation protocol (SIP) functionality (at the customer premises), with analog telephone interface (ATA) functionality embedded within the RG. Figure 5 represents RG with embedded ATA functionality.

- The ATA processes the VoIP call and presents it to the analog telephone via the standard analog telephone interface located within the RG.
- The RG with embedded ATA functionality may have more than one physical port for supporting multiple derived lines.

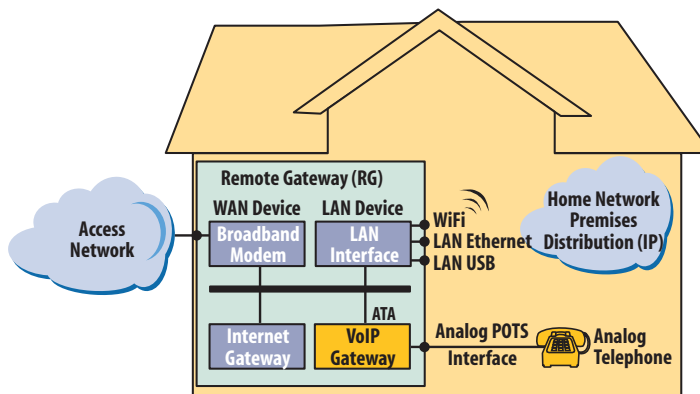

Figure 5: RG with Embedded ATA Functionality

This solution avoids network address and port translation (NAPT) issues and, therefore, does not benefit from nor require a VoIP Application Layer Gateway (ALG).

The ATA device converts VoIP to plain old telephone service (POTS) making it compatible with black phones or directly interfaces with SIP-based handsets.

Broadband Forum TR-104 [6] defines the VoIP object model, as Figure 6 illustrates, with statistics related to *performance* highlighted in red, and diagnostic *capabilities* highlighted in orange.

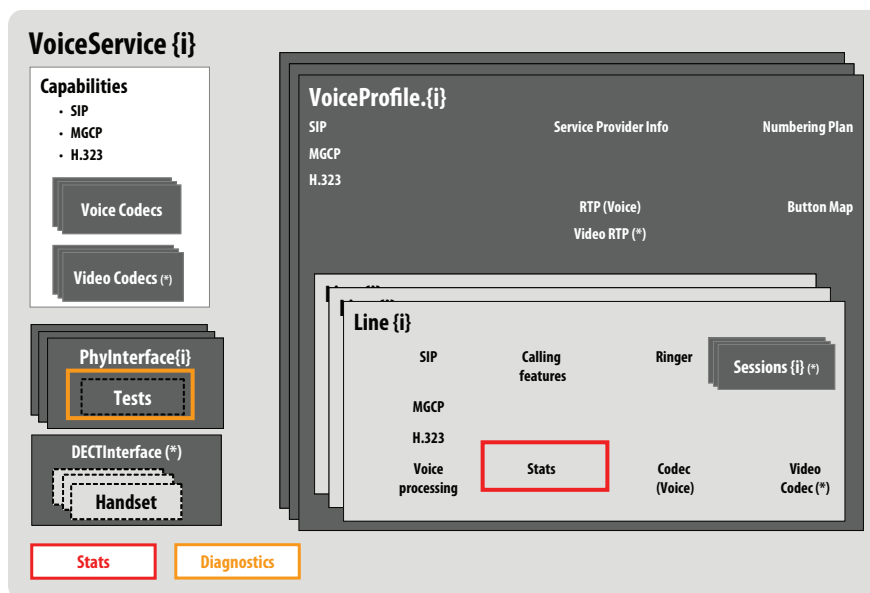

Figure 6: VoIP TR-104 {PD-149 (*)} ATA Object Model

Set Top Box for IPTV/Broadcast and Video on Demand/Unicast Delivery

Video services require an external STB to receive IP packets and decode the digital video stream prior to delivery to a television. The major functions of a STB are:

- Provides video decoder function for the entertainment media data stream and a software middleware client that controls security access to service subscriptions, digital rights management (DRM), electronic program guides (EPGs), billing, and more. Unlike terrestrial or satellite delivery mechanisms, IPTV supports a robust two-way communication beyond simply sending selected content to the network and receiving that content at the customer premises.
- Supports up to one or several high definition (HD) video streams and two or more standard definition (SD) video streams (up to a simultaneous bit rate of approximately 20 Mbps of real-time IP throughput)
- Supports different types of video architectures at home
 - One STB per every television set (the most common solution but requires the distribution of high-bit-rate, real-time streams throughout the home)
 - Multi-stream STBs that are able to simultaneously decode multiple channels and display them on multiple television sets

Figure 7 shows that the STB can be connected to a number of external networks, including *broadband networks* such as IP television (IPTV) and broadcast networks such as digital terrestrial television (DTT).

- The STB receives audio video (AV) streams from these external networks (if necessary via the RG), and combines them in various ways for presentation on one or more display devices (televisions), each of which can present different content. The end user chooses the content that is displayed.
- Displays can be connected to the STB via an analog connector, a specific digital connector, such as a high definition multimedia interface (HDMI) connector, or a digital network connector, such as an Ethernet or wireless local area network (WLAN) interface.
- Consumption of AV content is generally subject to rules imposed by means of conditional access (CA) or DRM systems. These systems may require the use of a smart card or may rely on encryption code integrated into the decoding chip.

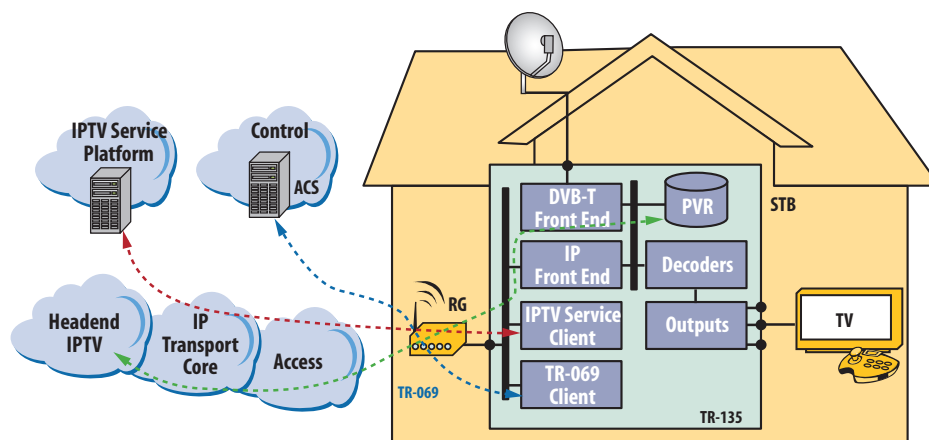

Figure 7: STB Context

- The personal video recorder (PVR) function can:
 - Send AV content, in compressed and possibly encrypted form, to a storage device
 - Record the content allowing it to be viewed after the recording is finished
 - Record video on demand (VoD) events

A proprietary IPTV service platform manages access to network and PVR content.

Normally, the STB is controlled by:

- The IPTV service platform for all tasks related to media processing and CA/DRM.
- The ACS for all tasks related to configuration and monitoring of operational status and performance.

Broadband Forum TR-135 [7] defines the object model for remote management of digital television, IPTV, or broadcast functionality on a STB CPE device by an ACS using the mechanism defined in TR-069. This specification includes how *performance management* is supported.

- The ACS carries out automatic monitoring of STB performance. Performance reports can include:
 - **QoS parameters**, for instance, network parameters such as average bit rate, jitter, and packet loss ratio
 - **Quality of experience (QoE) parameters**, such as visual quality or average channel change speed indicators
 - **Usage statistics**, such as how many STBs were on at a certain time, or the length of time each STB remained tuned to a certain channel

Monitoring campaigns may be performed:

- Periodically on all STBs to check that the network and CPE devices are working properly.
- On subsets of STBs, for instance, after identifying problems by means of periodic tests. Criteria to select subsets can be based on geography or tied to specific characteristics of the STBs (manufacturer, hardware, and/or software version).
- Periodically on specific STB devices, for example, the management of service level agreements (SLAs) for subscribers with premium services. Performance management could be used to continuously identify problems on these lines allowing trouble management technicians to act as soon as issues arise.

STB QoS and QoE reporting capabilities allow for in-service passive and proactive measurements to be taken at the service level. These performance measurements include total and sample statistics on the moving pictures expert group 2 transport stream (MPEG2-TS), real-time transport protocol (RTP) buffer over and/or underflow layers, as well as audience statistics.

End users who have measurements indicating a poor level of service can be proactively managed before the customer notifies customer care.

Figure 8 shows the TR-135 STB object model with statistics related to performance highlighted in red.

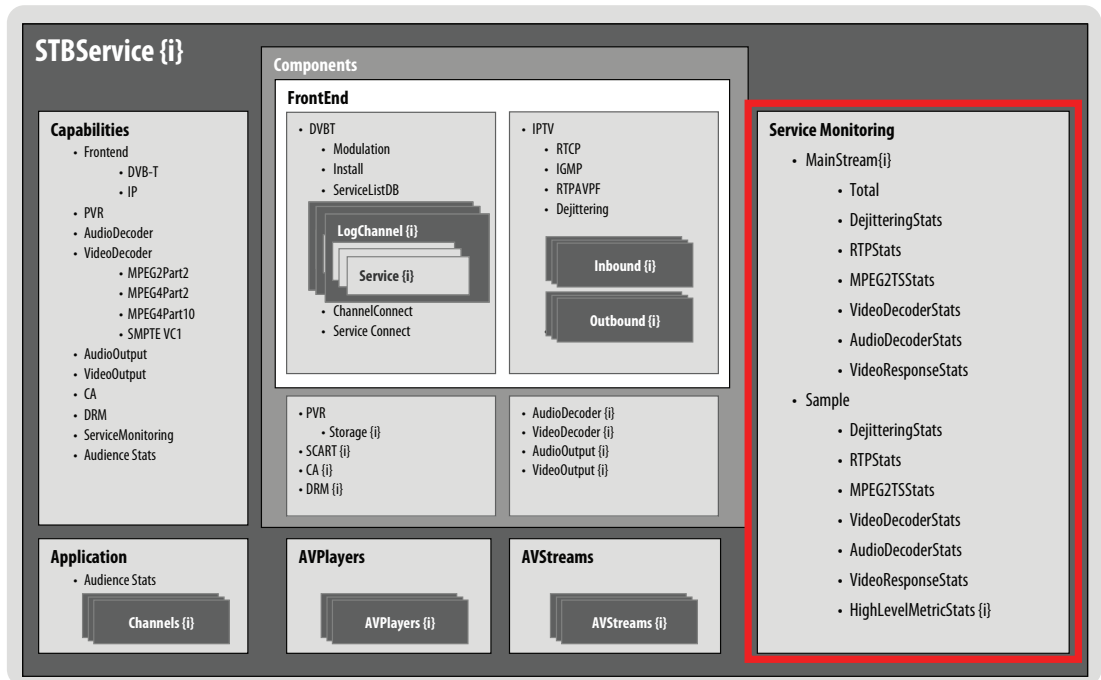

Figure 8: STB TR-135 Object Model

Service Providers' Quadruple-Play Business and Service Delivery Challenges

Increased competition from multiple system operators (MSOs), Telcos and IPTV service providers worldwide are driving the deployment of quadruple-play services. As a result, service providers are faced with many new business and service delivery challenges:

Lack of end-to-end visibility. As service providers roll out more IP-based services (data and real-time), they must eventually decommission older time division multiplexed (TDM) network components and replace them with leaner and more cost-effective IP-based network architectures. During and after this transition, service providers' will continually face two major issues:

1. IP services require a true end-to-end service view to competently perform QoS and QoE test and assurance.
2. Traditional service provider OSS infrastructures and organizations often lack the end-to-end service views necessary to assure their customers' QoS/QoE for these new services.

Reducing customer churn. The ability to offer quadruple-play services in attractive bundled packages is only half the battle. Service providers must also deliver the best QoE to their customers. Those who can do this and provide excellent customer care will retain and grow their customer base as well as position themselves to demand a premium in the market place.

Supporting rapid new services introduction. The introduction of IP Multimedia Subsystem (IMS) for fixed mobile convergence (FMC) in itself is a major challenge as providers must ensure their existing network architectures, operational models, and service assurance tools can easily migrate to support this new paradigm. FMC will not only allow the delivery of simultaneous quadruple-play services on any device at any time, anywhere but will also give service providers the flexibility to offer new services and business models to customers much faster than before, creating competitive differentiation.

Reducing operational costs. In order to handle broadband growth for millions of subscribers, operational models must be optimized introducing efficient service management and operational processes across the network and converged services architecture.

It is evident, that having visibility to and measuring QoE is an essential part of a service provider's competitive strategy for offering quadruple-play services. Providing a service assurance solution with the right mix of test and monitoring applications ensures the early detection and resolution of network, QoS, and QoE problems with limited or no customer impact. Such an effective service assurance solution must provide both proactive and reactive monitoring, as well as turn-up testing, troubleshooting, and fault isolation capabilities. Finally, all tools, network, and operational models must easily adapt to support new technologies and architectures such as FMC.

Quadruple-Play QoE and QoS Challenges

Service Providers face a number of major QoE/QoS measurement and visibility challenges while striving to deliver superior customer experience.

Proactively isolate intermittent impairments and address service quality issues?

- Intermittent service issues can result from many dynamic factors, such as network congestion, Digital Subscriber Line Access Multiplexer (DSLAM) load, Internet Group Management Protocol (IGMP) issues, and local loop performance.
- Not all IP impairments result in QoS/QoE issues. Hence, it is often difficult to identify which impairments will detrimentally affect service. For example, packet loss occurring in an IPTV network on the packet carrying a video frame can lead to picture problems such as blocking, freezing, or black screen. If the packet loss occurs intermittently, or once per day, the impact is much less severe than if it happens once per minute.
- Isolating causes of service impairments can be difficult, because IPTV involves interactions between the STB, the RG, DSLAM, edge switches, middleware, and DRM.
- IP services continuously evolve with technology shifts, code revisions, and network element (NE) and CPE firmware/hardware upgrades, which adds to the difficulty when isolating the causes of particular service impairments.

Continuously measure the true customer QoE?

- Service awareness can best be achieved from the QoE point of view of the subscriber.

Provide an end-to-end service quality view to isolate and demarcate faults?

- Collecting and correlating performance data across the entire delivery network (headend/source, transport and access network, access loop, and in the home) is required to ensure effective and accurate localization of problems.

Challenges with Local Loop Access

The loop access network is the physical broadband connection to the subscriber. It is generally copper-based for short enough loop lengths or fiber-based (FTTx architectures) for longer loop lengths. Copper allows for delivery of quadruple-play services from the Central Office (CO), while fiber-based architectures use active street cabinets and require significant investment for roll out. Voice, video, and data services are generally rolled out on limited bandwidth various DSL (xDSL) access loops. Managing the performance and capacity of the access network is paramount to the success of IPTV and all other IP services, because the local loop (access network) is the least reliable part of the delivery chain in the network. For success the service provider must:

- Maintain loop stability
- Minimize errors on the copper pairs
- Offer higher bandwidth simultaneously to every subscriber at a cheaper rate

Service providers using xDSL networks to support quadruple-play services must ensure that only good copper lines are used to provide the service. Hence, they must be able to manage their prequalification processes and procedures to exclude locations with concentrations of “bad” lines from marketing campaigns.

By continuously monitoring for service-impacting errors and signal performance on the xDSL loop, service providers can manage error control mechanisms, such as interleaving, to the depths necessary to eliminate errors and maximize served bandwidth, which preserves the ‘low latency’ experience for users on error-free lines. Users served by lines with impairments can trade-off slower maximum bandwidth for better IPTV/video experience. Table 2 lists potential challenges faced in the local area network (LAN).

What is Common?	What Can be Different?	Local Access Network Potential Problems (~25% of the problems)
Some form of xDSL	CO, fiber-to-the node (FTTN), fiber-to-the building (FTTB), fiber-to-the premise (FTTP)	Mis-provisioned network
Errors!!	Rate/reach	Protocol independent multicast (PIM)/IGMP Multicast performance
	Number of simultaneous streams	Policy management/over subscription
	Error correction	Error correction/channel fill capacity
		Loop performance and stability
		Noise and impulse on loop

Table 2: Challenges for the Local Access Network

Challenges in the Home Network

The home network must provide a reliable and secure infrastructure to carry IP-based quadruple-play services from the RG through the in-house LAN to the IP STBs. The RGs and STBs are typically managed by the Internet service provider. This presents a potential challenge to prioritize network fault management while offering an end-to-end service view, but it presents an opportunity to deliver user-centric quadruple-play services to the home.

Due to the complexity of the home network and the tremendous service impacts that even intermittent errors can have on QoE, service providers must implement continuous service visibility across the entire network, including the access loop, the RG, and home networks into the STBs. By continuously monitoring service performance at the STB and RG, service providers can quickly isolate faults that are caused by even intermittent errors. This type of monitoring will improve the quality of the customer experience, reduce operational costs, and lower Mean Time to Repair (MTTR). Finally, STB quality parameters will give service providers a real, objective performance metric they use to evaluate overall service performance on a real-time and aggregated basis. To support customer care efficiency, service assurance teams must have access to service performance data in the network, the loops, and into the home. Table 3 lists the potential challenges in the home.

What is Common?	What can be different?	Home Network Potential Problems (~50% of the problems)
TR-069 RG	The wide area network (WAN) and LAN types of interface	Impulse events
RG/STB link	STB vendors	RG performance
Network in the home		Security/Authentication/Policy management
Home errors		Home network and configuration The user

Table 3: Challenges for the Home

The JDSU NetComplete Home Performance Management (Home PM) Solution

The JDSU NetComplete Home PM solution enables multi-play service providers to extend their service assurance capabilities into the home providing full QoS and QoE reporting of customers suffering degraded service. With proactive service fault management and continuous performance monitoring of home networking equipment (RGs and beyond to CPE)—NetComplete Home PM automatically alerts providers to customers being impacted by degraded IPTV, VoIP or data services. Once service degrading issues are detected, NetComplete Home PM provides the critical information necessary to resolve the problem. Its rapid fault demarcation capabilities support in-service diagnostic testing and on-demand real-time data collection facilitating fault investigation and root-cause analysis reducing Mean Time to Repair (MTTR). The following sections describe the Home PM solution in more detail.

NetComplete Home PM

As previously discussed, QoS and QoE visibility at the customer premises is essential to ensure successful delivery and management of IP and real-time IP services. The JDSU NetComplete Home PM was designed to provide this customer premises (QoS/QoE) visibility.

The Home PM solution extends the service providers QoS/QoE visibility. This extension is achieved using data from CPE and network devices that support TR-069. Home PM also supports service testing for ADSL2+, and Very High Speed Digital Subscriber Line 2 (VDSL2) in the near future. By leveraging the TR-069 standards, Home PM further alleviates xDSL chip interoperability issues between different CPE devices and Multi-Service Access Nodes (MSANs). Key features of Home PM:

- Provides a comprehensive solution for multi-vendor CPE management: monitoring, diagnosis, and troubleshooting, which compliments existing zero-touch provisioning, configuration update, and software upgrade solutions.
- Provides the means to measure service availability in real-time and over longer periods to quickly pinpoint which service or part of the network might be contributing to service downtime/issues.
- Provides the added value of pre-packaged rules for root-cause analysis based on AT&T DSL networking experience. These packaged rules reduce the number of events that require attention and cut first-level diagnosis lead times enabling Network Operations Center (NOC) and customer support teams to become more efficient, pruning operational expenses.
- True end-to-end service assurance solution based on a carrier-class architecture that performs proactive monitoring and end-to-end tests from the home through the access, aggregation, edge, and transport networks up to the head-end to accurately detect and localize faults.
- A multi-vendor network and service management solution designed for rapid deployment. The system is based on the NetComplete portfolio specifically designed for broadband services, such as high-speed Internet, VoD, broadcast television, IPTV, and VoIP.
- A scalable, flexible, centralized, web-based solution that is easy to deploy.
- Very relevant for both CO and especially street cabinet applications. In the case of street cabinets, Home PM could prevent the need to deploy test heads or hardware probes, to carry out wideband and narrowband copper testing in these cabinets once Single-Ended Line Testing (SELT) and Metallic-Ended Line Testing (MELT) are supported under ADSL2+ and VDSL2 chip sets.
- Performs “in-service” assurance—monitors, tests, analyzes, and reports all the above without interrupting the customer’s service.

The Home PM solution is used throughout the life cycle of quadruple-play services, by:

- Performing multi-play proactive performance service-level monitoring.
- Automating the proactive collection of quality metrics from the RG, ATA, and STB.
- Performing advanced alarm correlation and root-cause analysis.
- Outputting results in an easy-to-use, intuitive dash-board frontend.
- Performing on-demand real-time measurement on any RG, ATA, and STB to verify the current functioning level.
- Performing remote diagnostic tests, to check the state of the different components of the RG or home devices. These tests are either scheduled periodically or launched by system service provider request.
- Providing notification of events/alarms through its north bound interface (NBI).

The JDSU ecosystem includes partnerships with leading IPTV middleware vendors, ACS vendors, home gateway vendors, as well as STB manufacturers.

Figure 9 illustrates all the statistics and diagnostics that are handled by NetComplete Home PM for home network, IPTV, and VoIP services:

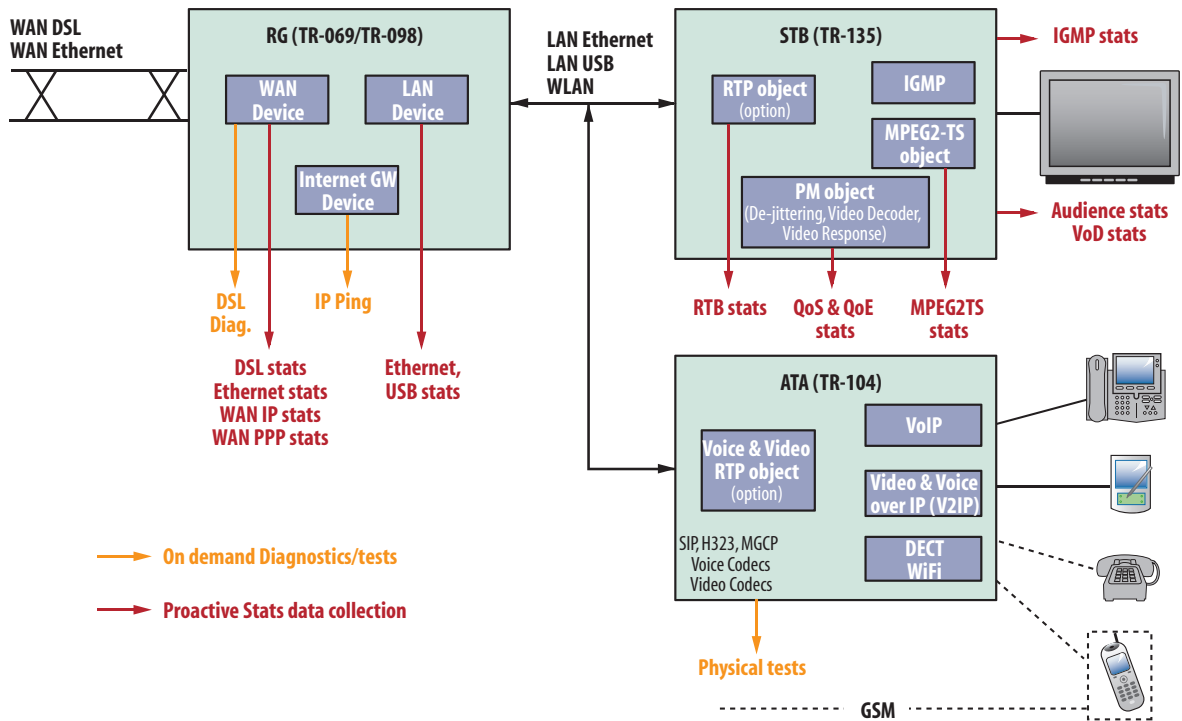

Figure 9: NetComplete Home PM Features

Home PM Virtual Probe

Home PM includes a *virtual probe concept*, as illustrated in Figure 10, that allows daily proactive monitoring of each perceived customer experience and automatically polls customers that are experiencing poor QoS more frequently.

By performing neighborhood and single end-user analysis, Home PM's virtual probe helps to identify cabling issues or network problems such as:

- **Aggregation or transport problem.** Identified by detecting similar problems for all customers in the same location (CO, City, or Region).
- **Faulty DSLAM board.** Identified by associating DSL synchronization problems on lines that are connected to same DSLAM.
- **Wrong or bad cable shielding** that induces noise interference on customers' lines. Detected as intermittent errors on a set of lines connected to the same CO or remote terminal (RT).
- **Bridged tap, crosstalk, and interferers.** Detected by analyzing the power spectrum density plots gathered through dual-ended line testing (DELT). Standards bodies have adopted this testing measure under the ITU-T ADSL2 or G.992.3 numbering scheme.
- **Cabling issues.** Caused as a result of line errors and line burst errors (errored seconds, block errors, and code violations), excessive line attenuation, or insufficient signal-to-noise ratio (SNR).
- **Insufficient transmission control protocol (TCP)/IP throughput.**
- **Home network issue** when good measurements show acceptable DSL statistics, but errors are detected on the LAN network.
- **Incorrect home device configuration** shown after comparing the current configuration with the expected configuration for service delivered.

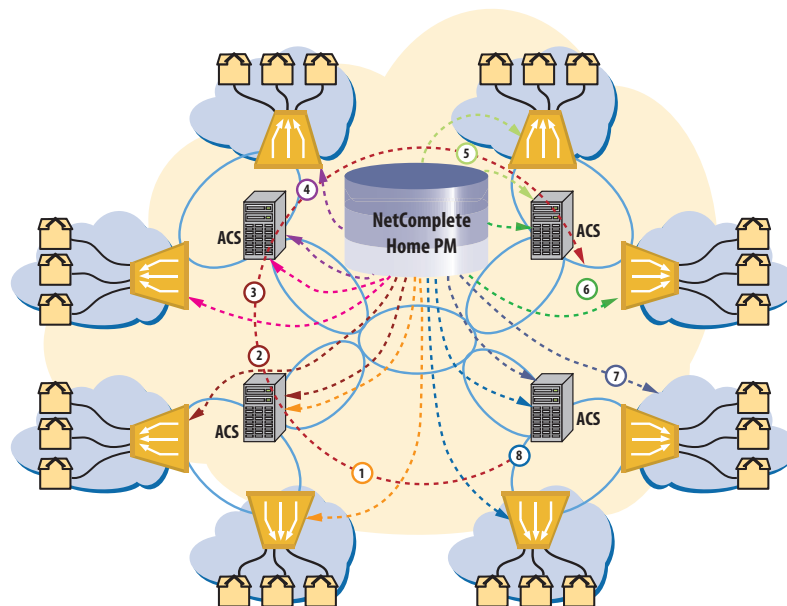

Figure 10: Home PM Virtual Probe Concept

Home PM is Ready for Quadruple Play

NetComplete Home PM also applies for FMC networks with unlicensed mobile access (UMA)⁴ when deploying femtocells⁵.

Femtocells are:

- One of the solutions mobile operators use to provide enhanced 2G and 3G mobile coverage within homes and small businesses.
- Cellular access points that connect to a mobile operator's network using residential DSL or cable broadband connections.
- Stand-alone units typically deployed in hot-spots, in-building, or in-home.

Advantages of femtocells include:

- Reduce deployment costs
- Do not require a new (dual-mode) handset
- Work with existing handsets
- Generate new revenue streams
- Speed up fixed-mobile substitution

Femtocells can generally be remotely managed using standard TR-069 and TR-196 management systems.

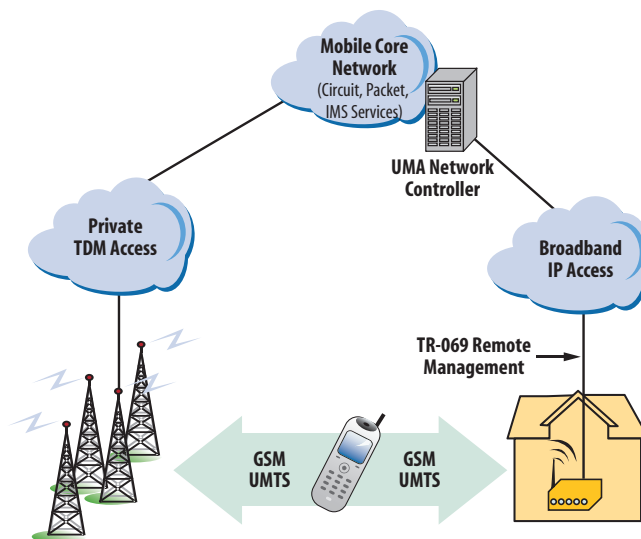

Figure 11: TR-069 Application for FMC Networks Based on Femtocells

⁴ UMA: One of the third-generation partnership project (3GPP) global standards for FMC. Enables secure, scalable access to mobile voice, data, and IMS services over broadband (DSL) IP access networks. Deploying UMA technology allows mobile operators to deliver a number of compelling FMC convergence services.

⁵ Femtocells, originally called access point base stations are scalable, multi-channel, two-way communication devices that extend a typical base station by incorporating all of the major components of the telecommunications infrastructure.

Home PM Value Proposition

Home PM provides the service provider home/customer premises QoS and QoE visibility on IP and real-time IP services to reduce operational costs and to increase customer satisfaction.

Home PM reduces operating costs by:

- Covering all phases of network life cycle from installation, commissioning, provisioning, to service delivery, operation, maintenance, repair, service assurance, and customer care.
- Covering all technologies related to the access network—physical, logical, and service layers (including quadruple-play services).
- Reducing the cost per fault by:
 - Improving dispatch accuracy through reduced truck rolls (dispatch to fix, not to find) and reduced unnecessary visits (dispatch the right person to the right place with the right tools the first time)
 - Reducing the need for handheld testers
 - Reducing fault volumes (lower volumes of trouble tickets and dispatches)
 - Reducing fault rates
- Optimizing process flows and operational costs by:
 - Control the process from the CO/customer care center
 - Improving the provisioning process
 - Improving quality and accuracy of test and diagnostics
 - Protecting current revenues and grow new business
 - Preventing customer care center growth

Home PM improves customer satisfaction and the end user experience by:

- Supporting both residential and enterprise customers
- Supporting customer care in the handling of customer complaints
- Improving the speed of repair (reducing mean time to identify/repair [MTTI/R])
- Reducing time to clear faults

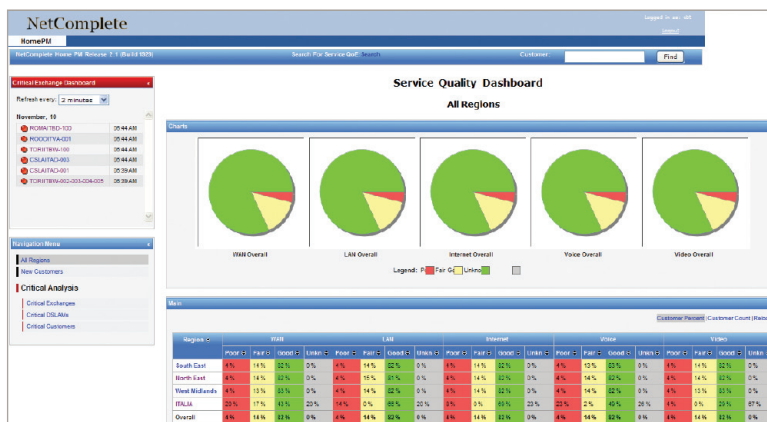

Figure 12: Home PM User Interface – Global Service Quality View

Figure 12 shows an example of the overall measured quality for all IPTV customers. Global quality is reported for the WAN and LAN interfaces as well as for IPTV service.

Clicking on the context-sensitive links allows users of the system to drill down to the measured quality for every end user as Figure 13 illustrates. In addition, users can obtain information regarding:

- DSLAMs with reports of the poorest quality
- End users experiencing the poorest quality
- Overall service quality for the past 12 months
- Quality rankings delivered by equipment type, such as DSLAMs, RGs, and STBs
- Perceived quality rankings for every delivered service

Figure 13 shows tools available for the service provider to determine fault types detected and to understand or confirm the root cause of the problem, such as:

- Performing diagnostics capabilities using DELT and Ping tests (on the WAN or LAN side of the RG)
- Verifying device configuration
- Polling the end user more frequently using the study mode
- Polling on-demand statistics
- Compiling history of the statistics

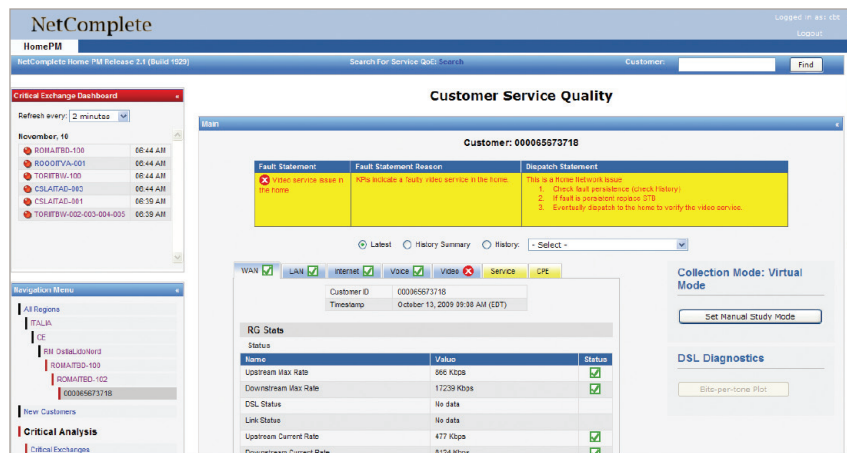
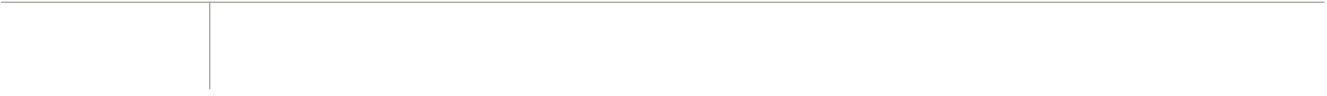

Figure 13: Home PM User Interface – Customer IPTV QoE

References

1. **JDSU NetComplete Service Assurance Solution**
www.jdsu.com/test_and_measurement/products/descriptions/SAS_IPTV/index.html
2. **Broadband Forum**
www.dsforum.org/
3. **Home Gateway Initiative**
www.homegatewayinitiative.org/
4. **TR-069: TECHNICAL REPORT - Broadband Forum TR-069 Amendment 1 - CPE WAN Management Protocol - November 2006**
www.dsforum.org/techwork/tr/TR-069%20Amendment%201.pdf
5. **TR-104: TECHNICAL REPORT - Broadband Forum - TR-104 - DSLHome™ - Provisioning Parameters for VoIP CPE - September 2005**
www.dsforum.org/techwork/tr/TR-104.pdf
6. **Home Gateway Technical Requirements: Release 1 - Version 1.0 – 1 July 2006**
www.homegatewayinitiative.org/publis/HGI_V1.0.pdf
7. **TR-135: Data Model for a TR-069-enabled STB**
www.dsforum.org/techwork/tworkingprogress.shtml
8. **JDSU NetAnalyst Test Management Software**
www.jdsu.com/test_and_measurement/products/descriptions/NetAnalystTM/index.html
9. **JDSU NetOptimize Operations Support System**
www.jdsu.com/test_and_measurement/products/descriptions/netoptimizecm/index.html?cat=product_categories&subcat=sas



Test & Measurement Regional Sales

NORTH AMERICA TEL: 1 866 228 3762 FAX: +1 301 353 9216	LATIN AMERICA TEL: +1 954 688 5660 FAX: +1 954 345 4668	ASIA PACIFIC TEL: +852 2892 0990 FAX: +852 2892 0770	EMEA TEL: +49 7121 86 2222 FAX: +49 7121 86 1222	WEBSITE: www.jdsu.com/test
---	--	---	---	---