

Today's Multi-Layered Networks

Today's networks use multiple hierarchies and technologies requiring multiple protocol adaptations and encapsulations to map Internet Protocol (IP) and Ethernet traffic (at Layers 2 and 3 [L2 and L3]) to the physical optical transport network. Therefore, to create an IP/Ethernet mesh between switches/routers requires mapping multiple physical interfaces to a connection-oriented transport network. These add/drop multiplexers (ADMs) aggregated this traffic to higher speed interfaces typically using Time Division Multiplexing (TDM) techniques prior to handing off to the dense wave division multiplexing (DWDM) transport plane. The resulting network implementation often results in underutilized infrastructure and resources due to inefficiency of the physical interfaces from the switches/routers. At the transport layer, fibers and the wavelengths they carry may also only be partially filled driving overall higher costs and operational complexities. Figure 1 illustrates a typical multi-hierarchical reference network.

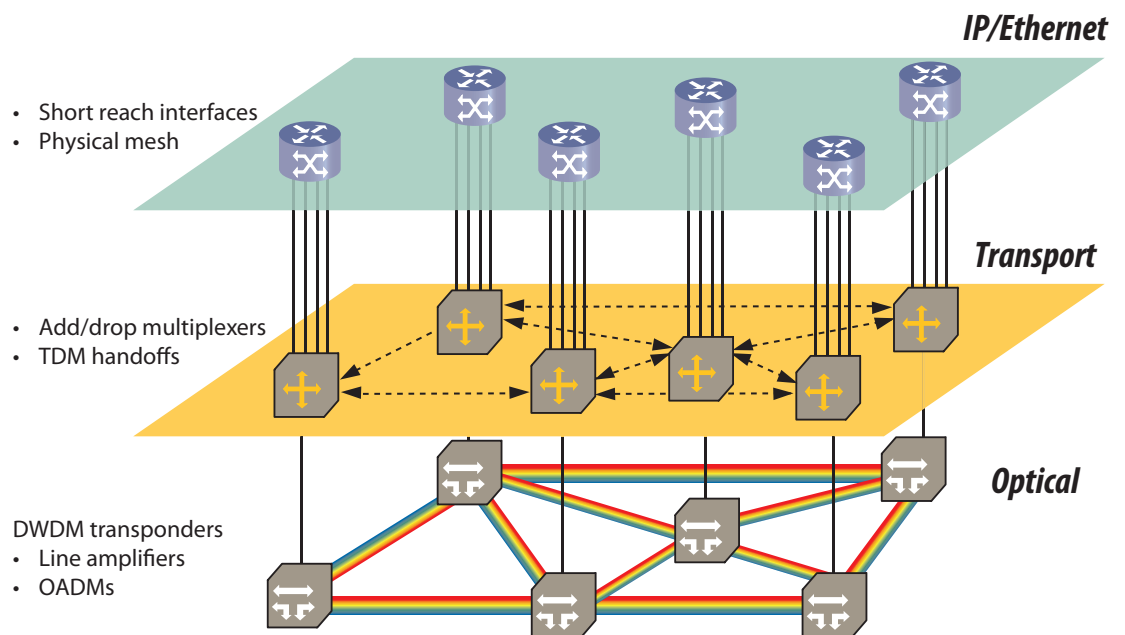

Figure 1. Multi-Layered Network

In this layered network approach, transponders convert short reach, uncolored signals into wavelengths. All traffic is passed to the router, which both increases costs and impacts performance. Switching can occur at L2, L1, or at the Optical Layer .

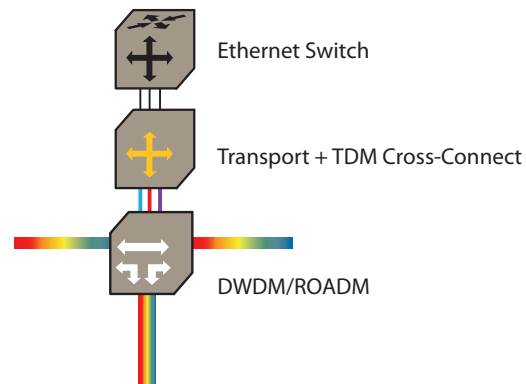

Figure 2. Role of Transponders in Multi-Layered Networks

Market Drivers for Network Delaying

The continued exponential growth of data traffic fueled by new video-intensive applications with increased mobile traffic demands and advanced enterprise services involving cloud computing is driving network operators to search for ways to improve network efficiencies and reduce costs. These are the compelling requirements operators must include:

- Deliver high bandwidth services at competitive prices, eliminating network layers and reduced total cost of ownership
- Simplify end-to-end L2 service provisioning and turn up new services quickly
- Support more complex network topologies, such as rings and meshes
- Provide fast fault detection and service restoration

The maturity of Carrier Ethernet standards and the availability of high-performance switch/router products now available from a variety of vendors enable network operators to truly realize the benefits of a converged packet optical network (PON). Today's solutions support a variety of services, such as Native Ethernet, L2/L3 VPN, VPLS, E-LAN, E-LINE with support for SONET/SDH-like operational capability including fast restoration capabilities.

These combined capabilities create the opportunity to reduce network cost and complexity with the elimination of a layer of multiplexing and adaptation and combining Ethernet/IP and DWDM optical networking, as shown in Figure 3.

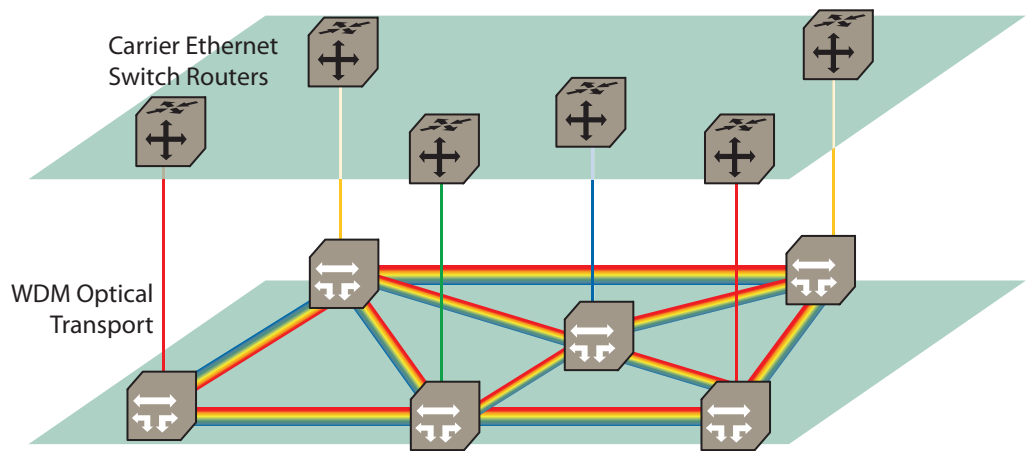

Figure 3. Delayed Network Architecture

Economic benefits are realized through lower operational and maintenance costs. Best of breed optical networking and Ethernet/IP platforms can provide efficiencies in power, space, sparing, network planning and training.

Two Primary Approaches for Implementing Delayed Networks

The two predominant approaches for implementing packet-optical networks include using integrated packet-optical transport platforms (P-OTP) or IP/Ethernet over DWDM. P-OTPs integrate Ethernet and TDM switching blades into a common platform or chassis to form an integrated optical transport platform. Transponders are inside transport platform eliminating the costs associated with external transponder systems. Wavelength selective switches (WSS) or reconfigurable optical add/drop multiplexers (ROADM) may also be integrated using separate blades in the same chassis. Often traffic is mapped into optical transport network (OTN) containers prior to being multiplexed onto the fiber.

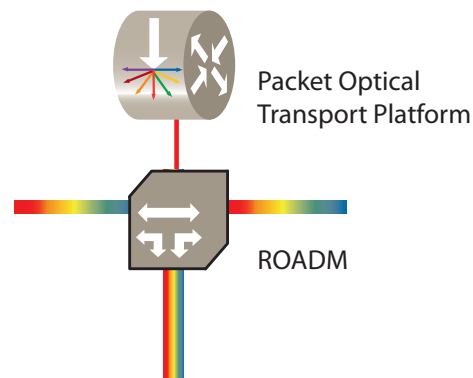

Figure 4. Packet Optical Transport (P-OTP) Building Blocks

With IP/Ethernet over DWDM architectures, Ethernet switch/routers use colored interfaces outputting DWDM wavelengths directly and also eliminating the costs associated with external transponders, as shown in Figure 5. WSS/ROADMs create a flexible optical transport layer, directing only specific wavelengths to the switch/router, thereby reducing both port count and resource demands of the switch/router itself. DWDM transport later utilization is determined on a wavelength level. Wavelengths can be filled using packet multiplexing, statistical multiplexing, and traffic management.

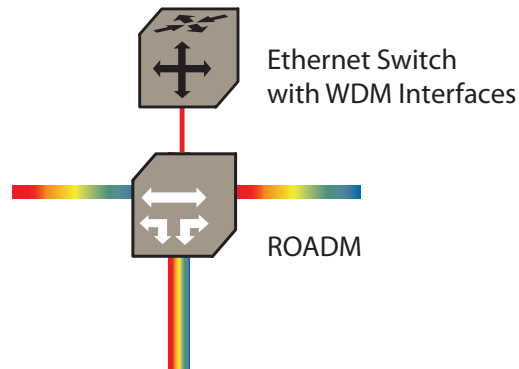

Figure 5. IP/Ethernet over DWDM Building Blocks

Comparing P-OTP and IP/Ethernet-over-DWDM

While combining all layers into a single P-OTP provides certain benefits, it also requires many considerations. In some implementations, although the adaptation layer may be physically eliminated, the functionality remains integrated into blades within the platform. Therefore, the cost, overhead, and latency resulting from these encapsulations, such as SONET/SDH, generic framing procedure (GFP), or OTN remain. Because P-OTPs combine multiple functions into a single physical chassis, while supporting many different protocols and rates, interface densities are often limited. Lastly, technology innovation cycles differ. Typically, IP/Ethernet standards and implementations evolve more rapidly than optical transport solutions resulting in more, and more frequent, new hardware and software releases from network equipment manufacturers. Each evolution creates challenges for operators who must balance the need for new features with the operational cost and complexity resulting from frequent network upgrades. Furthermore, the foundation of any network is the optical transport layer; therefore, operators are cautious about frequent network changes or churn because it could impact network reliability or performance.

IP/Ethernet over DWDM architectures allow operators to use best-of-breed technologies at each layer and allows for independent optimization of each layer for both cost and functionality. Because the Ethernet/IP layer is independent, operators can implement switch/routers from multiple vendors. The independency of the Ethernet/IP layer releases it from the physical packaging requirements of having to fit into a common chassis or platform, resulting in fewer compromises in terms of forwarding/routing performance and interface densities. Increased packet processing and traffic management requirements exist as more services are IP based, requiring wire rate performance for all protocols, including multicast. Eliminating latency-penalizing adaptations or encapsulations and keeping protocols native helps IP/Ethernet over DWDM architectures effectively deliver new latency-sensitive services, including interactive high definition video. Finally, operators can capitalize on the rapid innovation cycle occurring with Ethernet/IP implementations without disturbing the optical transport layer and increasing service risk or reliability. Figure 6 shows the comparison between integrated P-OTP and IP/Ethernet over DWDM architectures.

Integrated Packet-Optical

IP/Ethernet over DWDM

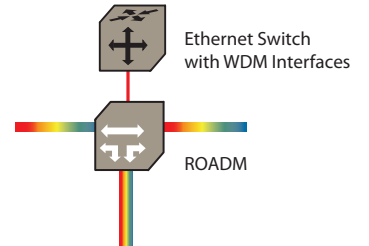
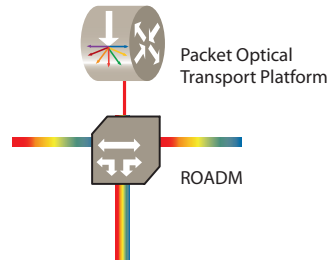

<p>Primary Advantages</p>	<ul style="list-style-type: none"> • Integrates multiple platforms into one • Supports legacy TDM services 	<ul style="list-style-type: none"> • Highly scalable Layer 2 and Layer 3 data plane • Maximum flexibility for offering packet-based services • Lower CapEx by reducing number of switching layers • High port density
<p>Considerations</p>	<ul style="list-style-type: none"> • Multiple encapsulations, adaptations (for example, GFP, OTN) • Usually interface lower densities and scalability 	<ul style="list-style-type: none"> • Packet only interfaces and services • OTN aggregation may be required for legacy services
<p>Suitability</p>	<ul style="list-style-type: none"> • Lower port counts • Wholesale private line services • Layer 2 with thin Layer 3 requirements • Nx10G 	<ul style="list-style-type: none"> • Multicast-based services • Layer 2 and IPVPNs • High port count, aggregation, and traffic management requirements • Mesh traffic patterns, any-to-any • Nx10G

Figure 6. Comparison of P-OTP and IP/Ethernet over DWDM Delayed Networks

Conclusion

Industry analysts, such as Infonetics, report that operators are moving toward IP/Ethernet over DWDM, predicting that 70 percent of operators will have implemented it in some fashion by 2012, increasing to 85 percent by 2015. While both P-OTN and IP/Ethernet over DWDM address many of the same challenges, the two implementations are often complementary, giving operators flexibility in determining when and where to deploy either solution. Typically, P-OTNs are more suited for deployments involving 'thin' Ethernet/IP requirements (for example, deployments with limited quality of service [QoS] and traffic management requirements) and those that require a lower number of interfaces. IP/Ethernet over DWDM architectures are especially suited for supporting more sophisticated, data-intensive services that require more traffic management, QoS, and packet processing. Simultaneously, these architectures can support ultra low latency transport of native protocols, such as uncompressed high definition video and Fibre Channel, within the same platform.



Test & Measurement Regional Sales

NORTH AMERICA TEL: 1 866 228 3762 FAX: +1 301 353 9216	LATIN AMERICA TEL: +1 954 688 5660 FAX: +1 954 345 4668	ASIA PACIFIC TEL: +852 2892 0990 FAX: +852 2892 0770	EMEA TEL: +49 7121 86 2222 FAX: +49 7121 86 1222	WEBSITE: www.jdsu.com/test
---	--	---	---	--