

Miniature Integrated Power Monitor

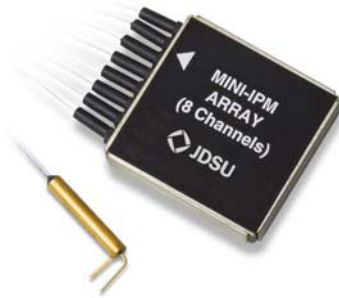

Key Features

- High reliability
- Compact footprint with ultra-wide bandwidth
- Extremely low wavelength dependent loss (WDL) and PDL
- Up to 8-channel arrays

Applications

- EDFA
- Raman amplifiers
- Add/Drop monitoring
- DWDM systems

JDSU miniature integrated power monitors are designed for channel monitoring in dense wavelength division multiplexing (DWDM) systems and Add/Drop modules. They can also be used for signal/pump power monitoring in erbium doped fiber amplifiers (EDFAs) and Raman amplifiers where integrated solutions tend to replace traditional fused fiber tap + photodiodes. The miniaturized version is a high performance active hybrid device that incorporates a micro-optic tap coupler and high-sensitivity InGaAs photodiode in a miniature package. It offers high reliability, compact footprint with ultra-wide bandwidth, and very low polarization dependent loss (PDL).

2

IPM Single Unit Diagram

(Specifications in mm unless otherwise noted.)

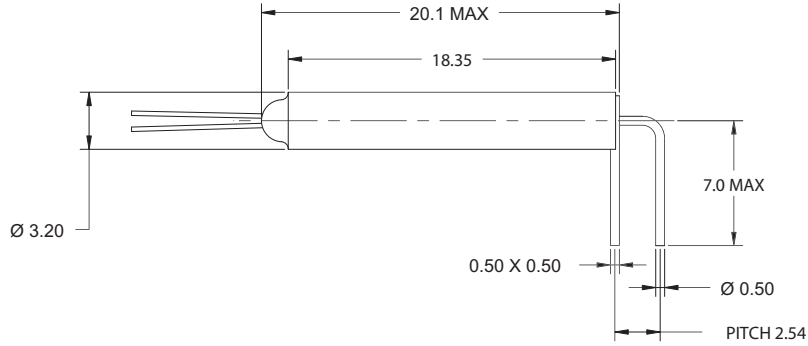

IPM Array (6 to 8 channels) Diagram

(Specifications in mm unless otherwise noted.)

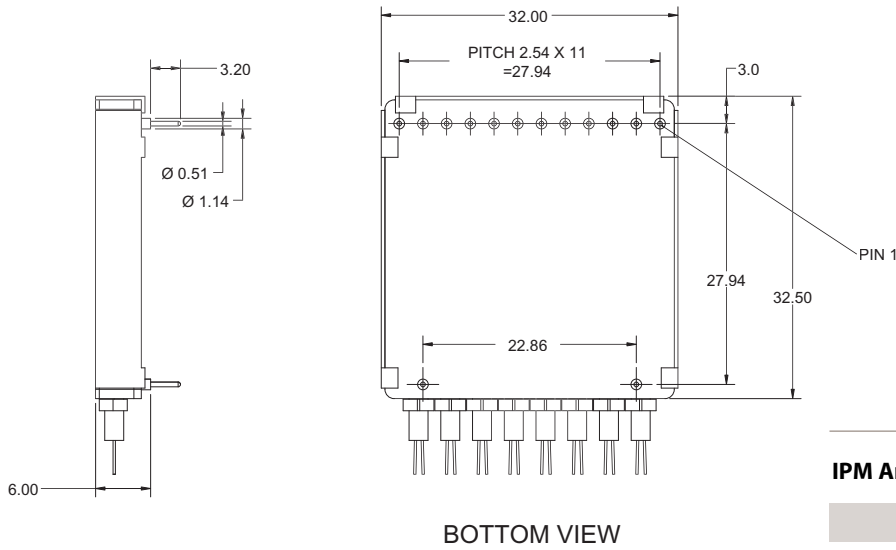

IPM Array Pinout (8 channel only)

| Pin | Description |
|-----|----------------|
| 1 | Anode (Common) |
| 2 | Cathode 1 |
| 3 | Cathode 2 |
| 4 | Anode (Common) |
| 5 | Cathode 3 |
| 6 | Cathode 4 |
| 7 | Cathode 5 |
| 8 | Anode (Common) |
| 9 | Cathode 6 |
| 10 | Cathode 7 |
| 11 | Anode (Common) |
| 12 | Cathode 8 |

3

Specifications

| Parameter | | Specification |
|---|---------|---|
| Wavelength range | | |
| C-Band | | 1510-1580 nm |
| L-Band | | 1560-1625 nm |
| C+L Band | | 1510-1625 nm |
| Insertion loss (input to output) | Maximum | See table below |
| Wavelength flatness (input to output) | Maximum | 0.002 dB/nm |
| Polarization dependent loss (input to output) | Maximum | 0.03 dB |
| PMD (input to output) | Maximum | 0.1 ps |
| Optical return loss | Minimum | 45 dB |
| PD operating bias voltage, V_R | | -5 V (typical) |
| PD responsivity | Minimum | 0.8 A/W (for net responsivity, see table below) |
| PD linearity | | $\pm 10\%$ |
| PD dark current | Maximum | 1 nA @ $V_R = -5$ V and 23°C |
| PD cut-off frequency | | Minimum 300MHz @ $V_R = -5$ V and $R_L = 50 \Omega$ |
| Input optical power | Maximum | See table below |
| Operating temperature | | -20 to 75°C |
| Storage temperature | | -40 to 85°C |
| Tensile load | Maximum | 5 N |
| Package dimensions | | |
| Single unit | | 3.2 mm x 18.5 mm |
| 6 to 8 channels array | | 32 mm x 32.5 mm x 6 mm |
| Fiber type | | SMF-28, 250 μ m primary coating |
| Pigtail color code | | Black (input port); Clear (output port) |

Note: Parameters are specified for the signal wavelength range, all polarization states, and operating temperature range without connector unless otherwise stated.

Tap Ratio and Insertion Loss Table

| Code | Tap Ratio | Maximum Insertion Loss (Input to Output) | Minimum Net Responsivity ¹ | Maximum Optical Power ² |
|------|-----------|--|---------------------------------------|------------------------------------|
| 1 | 1% | 0.5 dB | 0.008 A/W | 500 mW |
| 2 | 2% | 0.5 dB | 0.016 A/W | 250 mW |
| 3 | 3% | 0.5 dB | 0.024 A/W | 150 mW |
| 4 | 4% | 0.5 dB | 0.032 A/W | 125 mW |
| 5 | 5% | 0.6 dB | 0.040 A/W | 100 mW |
| T | 10% | 0.8 dB | 0.080 A/W | 50 mW |

1. The net responsivity is defined as the ratio of the PD current output and optical power measured at output fiber.

2. The maximum optical power is the maximum value of the power at input port within the PD linearity range specified.

Ordering Information

For more information on this or other products and their availability, please contact your local JDSU account manager or JDSU directly at 1-800-498-JDSU (5378) in North America and +800-5378-JDSU worldwide or via e-mail at customer.service@jdsu.com.

Sample: IPM-C82310010
