

RoHS-Compliant 4.25, 2.125, 1.25, 1.063 Gbps, Single-mode 1310 nm SFP Transceiver

JSH-42L4DD1



Key Features

- 1310 nm Fabry-Perot (FP) laser
- 5 km distance for 4 G Fibre Channel
- >10 km distance for Gigabit Ethernet and 2 G Fibre Channel with rate select
- Case operating temperature of -40 to 85°C
- Single +3.3 V power supply
- Hot pluggable
- Serial ID and digital diagnostics over 2-wire interface
- Industry standard duplex LC optical connector
- Operates with 9/125 μm single mode optical fibers
- RoHS compliant

Applications

- Gigabit Ethernet
- 4.25, 2.125, 1.06 Gbps Fibre Channel
- High-speed storage area networks
 - Switch and hub interconnect
 - Mass storage systems interconnect
 - Host adapter interconnect
- Computer cluster cross-connect
- Custom high-speed data pipes
- Client/server environments
- Visualization, real-time video, collaboration

Compliance

- Gigabit Ethernet (1000 Base-LX) at 1.25 Gbps
- FC-PI-2 400-SM-LC-M
- INF-8074 SFP (Small Form Factor Pluggable Transceiver), Rev 1.0
- SFF-8472 Diagnostic Monitoring Interface for Optical Transceivers, Rev 10.4

The JDSU JSH-42L4DD1 SFP transceiver is a hot-pluggable, 3.3 V, duplex-LC transceiver designed for use in Fibre Channel applications up to 4.25 Gbps and in Gigabit Ethernet applications at 1.25 Gbps with rate select. The multi-rate feature enables it use in a wider range of system applications. It is compliant with FC-PI-2 400-SM-LC-M, 200-SM-LC-L, 100-SM-LC-L, and 1000Base-LX specifications. The rate select pin (pin 7) along with the software rate select option provides optimized link performance between 4.25G/2.125G and 2.125G/1.25G/1.0625G line rates. These transceivers provide the LC optical receptacle that is compatible with the industry standard LC connector.

The transceiver consists of an optical subassembly housing the transmitter and receiver, and an electrical subassembly. All are packaged together with a top metal cover and bottom shield. The optical subassembly consists of two parts. The transmitter side has a high-performance, 1310 nm Fabry-Perot laser with back-facet monitor. The receiver side has an InGaAs PIN and a preamplifier.

The digital diagnostic monitoring (DDM) interface uses the same two-wire serial ID interface defined in the SFP MSA specification. The standard serial ID information is located at address A0h. Using address A2h, the user can monitor transceiver parameters, including temperature, voltage, laser bias current, laser power, and receiver power. Alarms and warnings are provided when the monitored parameters exceed predefined threshold values. All transceivers include a loss-of-signal-detect circuit, which provides a TTL logic high output when an unusable input optical signal level is detected.

2

Absolute Maximum Ratings

Parameter	Symbol	Min.	Max.	Unit
Storage temperature ¹	T _S	-40	+95	°C
Relative humidity ²	RH	5	95	%
Supply voltage	V _{CC}		4.0	V

1. Case temperature
2. Noncondensing

Recommended Operating Conditions

Parameter	Symbol	Min.	Max.	Unit
Ambient operating temperature at -40°C and case temperature at 85°C	T _{OP}	-40	+85	°C
Supply voltage	V _{CC}	2.97	3.63	V
Transmitter differential input voltage	V _D	0.5	2.4	V
Transmit disable input voltage—LOW ¹	TD _{Lo}	0.0	0.8	V
Transmit disable input voltage—HIGH ¹	TD _{Hi}	2.0	V _{CC}	V
Rate Select input voltage—LOW ²		0.0	0.8	V
Rate Select input voltage—HIGH ²		2.0	V _{CC}	V

1. Transmit disable input has a 4.7 to 10 kΩ pullup to V_{CC} inside the module.
2. Rate Select pin is left floating (tri-state) internally. The host must pull this pin LOW or HIGH depending upon the application.

FC Compliance with Rate Select

Parameter	100-SM-LC-L	200-SM-LC-L	400-SM-LC-M
HIGH	Yes	Yes	Yes
LOW	Yes ¹	Yes	No

1. Also 1000Base-LX compliant

3

Electrical Characteristics

(Over specified T_{OP} range, $V_{CC} = +2.97$ V to $+3.63$ V)

Parameter	Symbol	Min.	Typ.	Max.	Unit
Power consumption	P_{diss}			1000	mW
Total supply current	I_{CC}		200	275	mA
Transmitter					
TX fault output—HIGH ²	V_{oh}	2.0		$V_{CC} + 0.3$	V
TX fault output—LOW	V_{ol}	0.0		0.8	V
Initialization time				300	ms
Receiver					
Data output voltage swing (differential)	V_{diff}	0.5		1.2	V
Data output rise and fall times ¹	t_r, t_f			130	ps
Loss of signal detect output—HIGH ²	V_{oh}	2.0		$V_{CC} + 0.3$	V
Loss of signal detect output—LOW ²	V_{ol}	0.0		0.8	V

1. 20 – 80%

2. Output is open collector, and should be pulled up to a voltage between 2.0 and $V_{CC}+0.3$ V by the host

Optical Characteristics

(Over specified T_{OP} range, $V_{CC} = +2.97$ V to $+3.63$ V)

Parameter	Symbol	Min.	Typ.	Max.	Unit
Transmitter					
Average optical output power ¹ 9/125 μ m, NA = 0.10 fiber	P_{OUT}	-8.4		-3.0	dBm
Optical extinction ratio	ER	9			dB
GbE (Rate Select = LOW)					dB
4GFC (Rate Select = HIGH)			6		dB
Optical modulation amplitude					mW
1GFC (Rate Select = LOW)			0.30		mW
2GFC (Rate Select = LOW)			0.30		mW
4GFC (Rate Select = HIGH)		0.15	0.35		mW
Center wavelength	λ_c	1270		1360	nm
Spectral width ¹				(See note ¹)	nm
Optical rise/fall time ²	t_r / t_f			90	ps
Relative intensity noise	$RIN_{12}(OMA)$			-120	dB/Hz
Receiver					
Minimum optical input power (sensitivity)	P_{IN}				dBm
1GbE (Rate Select = LOW)				-19	dBm
1GFC (Rate Select = LOW)				0.015	mW (OMA)
2GFC (Rate Select = LOW)				0.015	mW (OMA)
4GFC (Rate Select = HIGH)				0.029	mW (OMA)
Maximum optical input power (saturation)	$P_{IN,max}$	1.0			dBm
Operating center wavelength	λ_c	1265		1365	nm
Return loss		12			dB
Loss of signal—deasserted	P_A			-20	dBm avg.
Loss of signal—asserted	P_D	-30			dBm avg.
Loss of signal—hysteresis	$P_A - P_D$	0.5		5.0	dB

1. Specified to meet triple trade off curves between wavelength, optical modulation amplitude, and spectral width, per FC-PI-2 Revision 10.0, Figures 18 through 21.

2. 20 – 80%, unfiltered, measured through a 4th order Bessel-Thompson filter with $0.75 * \text{Data Rate}$ 3-dB bandwidth and corrected to the full bandwidth value.

4

SFP Pin Definitions

Pin	Symbol	Description of Function
1	VeeT	Transmitter Signal Ground
2	TX Fault	Transmitter Fault Indication
3	TX Disable	Transmitter Disable
4	MOD – DEF2	Module Definition 2
5	MOD – DEF1	Module Definition 1
6	MOD – DEF0	Module Definition 0
7	Rate Select	Application Select between HIGH and LOW bandwidth operation
8	LOS	Loss of Signal
9	VeeR	Receiver Signal Ground
10	VeeR	Receiver Signal Ground
11	VeeR	Receiver Signal Ground
12	RD-	Received Data Inverted Differential Output
13	RD+	Received Data Noninverted Differential Output
14	VeeR	Receiver Signal Ground
15	VccR	+3.3 V Receiver Power Supply
16	VccT	+3.3 V Transmitter Power Supply
17	VeeT	Transmitter Signal Ground
18	TD+	Transmitter Data Noninverted Differential Input
19	TD-	Transmitter Data Inverted Differential Input
20	VeeT	Transmitter Signal Ground

Pin Function Definitions

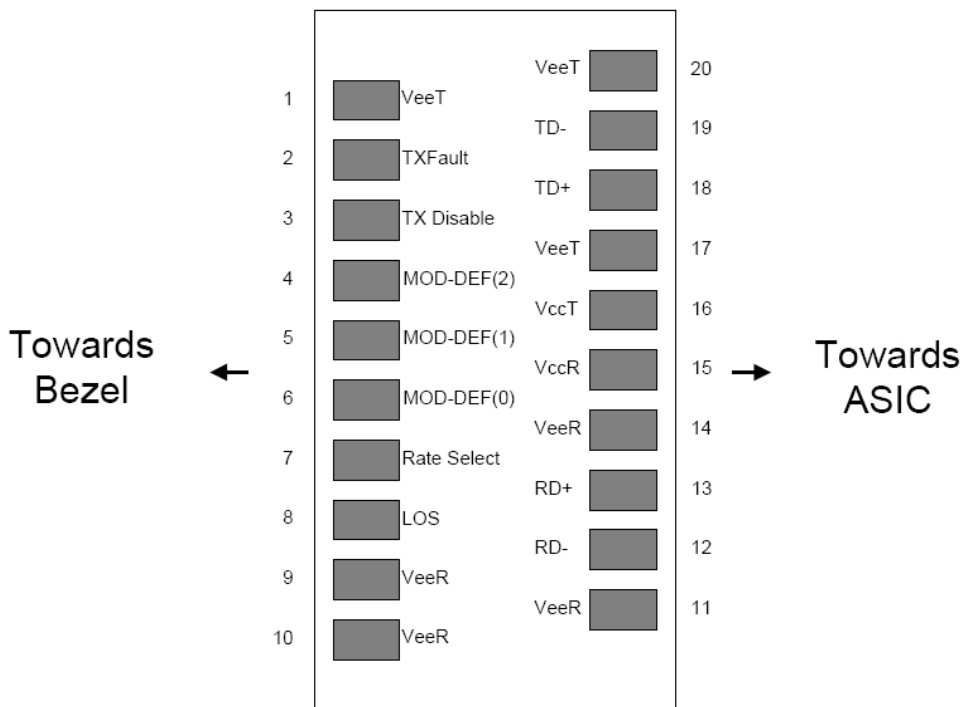

SFP optical transceiver pin-out on host board

5

Block Diagram

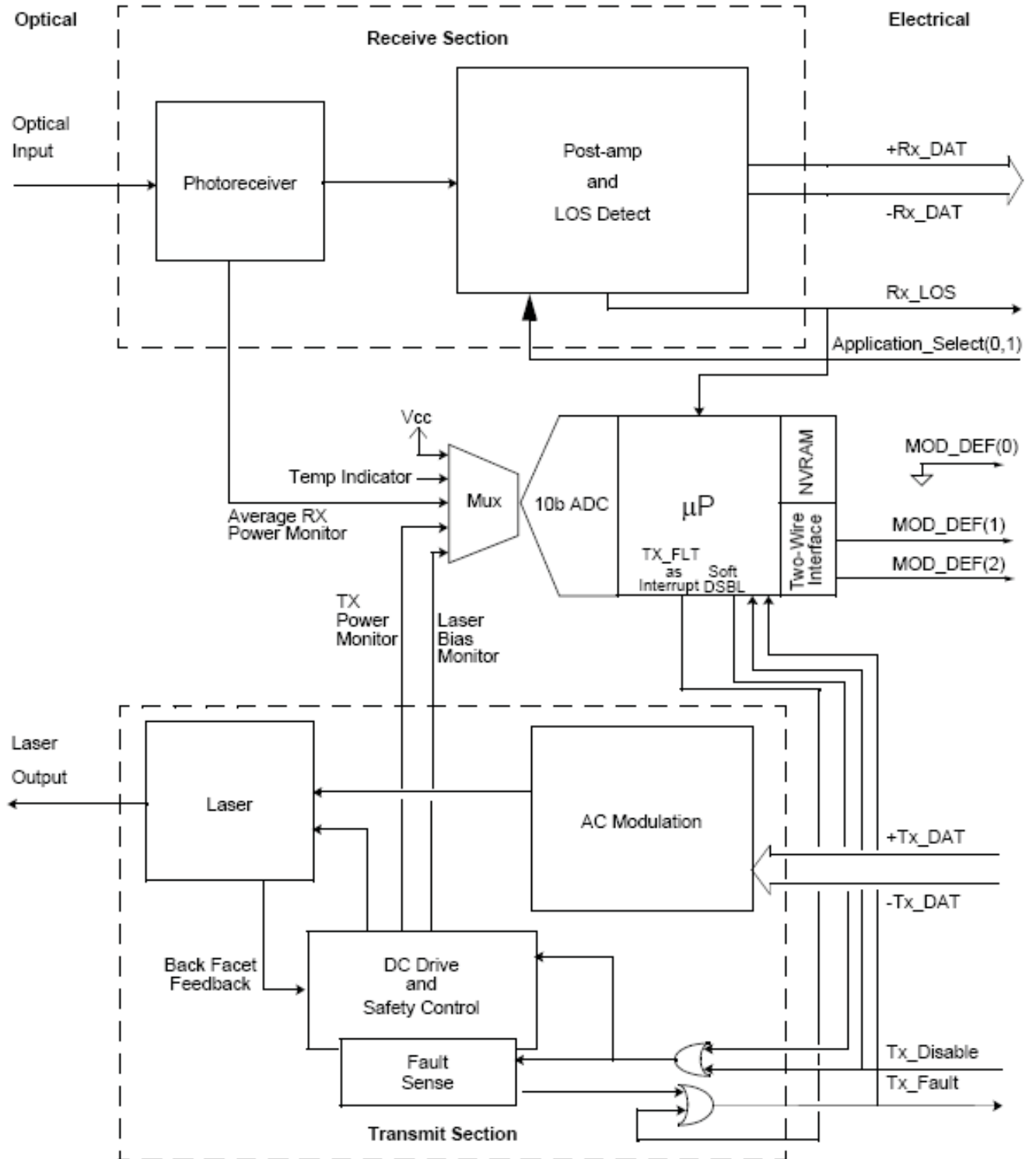

6

Recommended Power Supply Filter Network

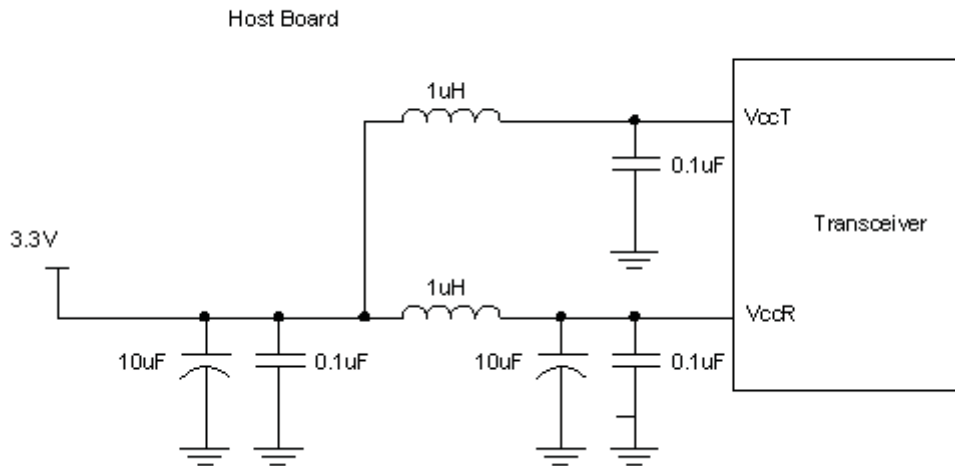

Notes:

1. Power supply filtering components should be placed as close to the Vcc pins of the host connector as possible for optimal performance.
2. ESR of inductor should be less than 0.5 ohm to ensure proper power supply levels.

Regulatory Compliance

The JSH-42L4DD1 complies with international electromagnetic compatibility (EMC) and international safety requirements and standards (see details in table below). EMC performance is dependent on the overall system design. Information included herein is intended as a figure of merit for designers to use as a basis for design decisions.

The JSH-42L4DD1 is lead-free and RoHS-compliant per Directive 2002/95/EC of the European Parliament and of the Council of 27 January 2003 on the restriction of the use of certain hazardous substances in electrical and electronic equipment.

The JSH-42L4DD1 is engineered for product safety and regulatory agency compliance. Approvals are anticipated based on engineering design and manufacturing practices that have been historically demonstrated by JDSU.

Regulatory Compliance		
Feature	Test Method	Performance
Component safety	UL 60950 UL94-V0 IEC 60950	cTUVus Certification
RoHS compliance	Directive 2002/95/EC	TUV Report/Certificate (CB scheme) Compliant per the Directive 2002/95/EC of the European Parliament and of the Council of 27 January 2003 on the restriction of the use of certain hazardous substances in electrical and electronic equipment
Laser eye safety	EN 60825 U.S. 21CFR 1040.10	TUV Certificate CDRH compliant and Class 1 laser eye safe
Electromagnetic Compatibility		
Electromagnetic emissions	EMC Directive 89/336/EEC FCC CFR47 Part 15 IEC/CISPR 22 AS/NZS CISPR22 EN 55022 ICES-003, Issue 4 VCCI-03	Noise frequency range: 30 MHz to 40 GHz. Good system EMI design practice required to achieve Class B margins.
Electromagnetic immunity	EMC Directive 89/336/EEC IEC /CISPR/24 EN 55024	
ESD immunity	EN 61000-4-2	Exceeds requirements. Withstands discharges of; 8 kV contact, 15 kV air
Radiated immunity	EN 61000-4-3	Exceeds requirements. Field strength of 10 V/m RMS, from 10 MHz to 1 GHz. No effect on transmitter/receiver performance is detectable between these limits.

8

SFP Transceiver Package Outline

(Dimensions in mm unless otherwise noted.)

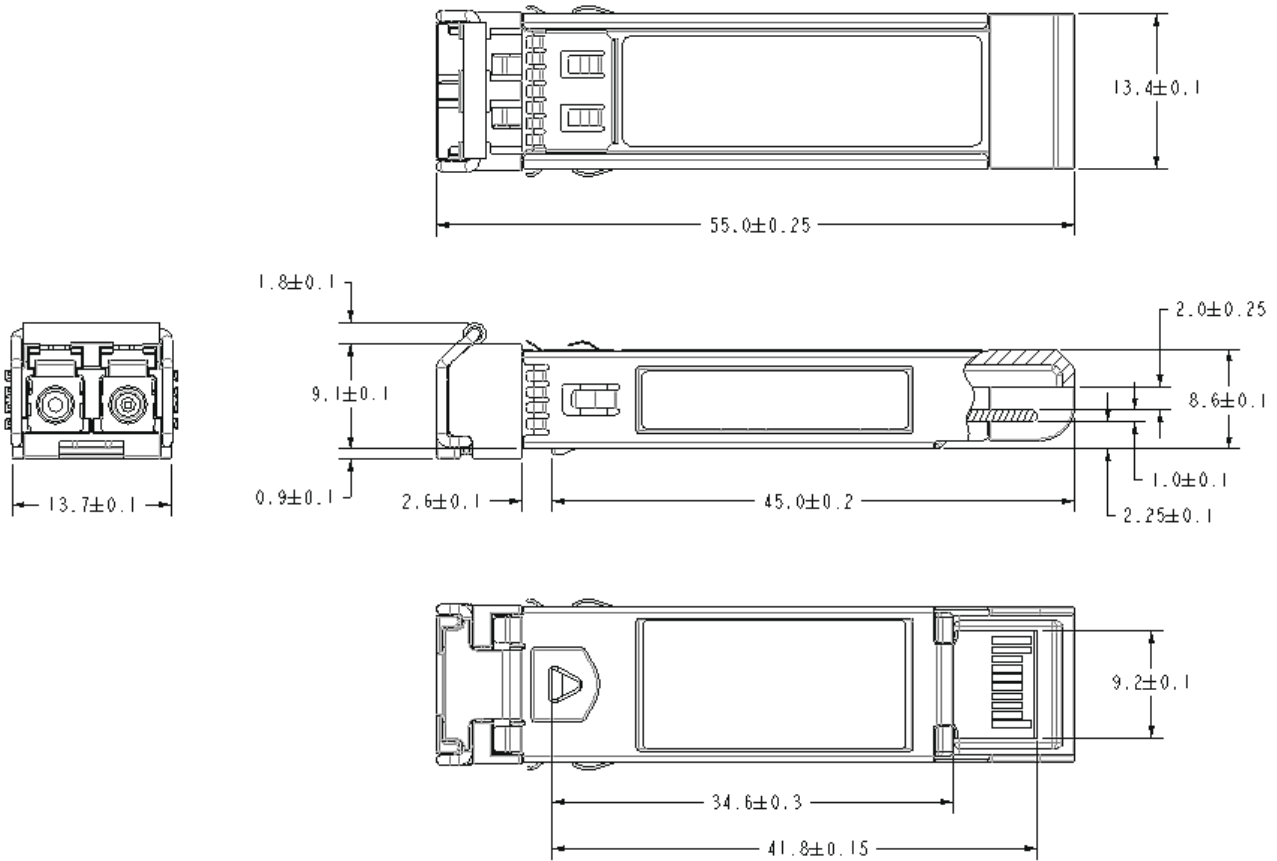

Digital Diagnostic Monitoring and Serial ID Operation

The JSH-42L4DD1 is equipped with a two-wire serial management processor/EEPROM used to store information about the type and identification of the transceiver, as well as real-time digitized information relating to transceiver performance. See the SFF Committee document SFF-8472 Rev. 10.4, dated January 30, 2009, for memory/address organization of the identification data and digital diagnostic data.

The enhanced digital diagnostics feature monitors five key transceiver parameters that are internally calibrated and should be read as absolute values and interpreted as follows:

Transceiver Temperature in Degrees Celsius: Internally measured. Represented as a 16 bit signed two's complement value in increments of $1/256^{\circ}\text{C}$ from -40 to $+85^{\circ}\text{C}$ with LSB equal to $1/256^{\circ}\text{C}$. Reported temperature accuracy is $\pm 3^{\circ}\text{C}$ relative to module case temperature.

Vcc/Supply Voltage in Volts: Internally measured. Represented as a 16 bit unsigned integer with the voltage defined as the full 16-bit value (0 – 65535) with LSB equal to 100 uV with a measurement range of 0 to +6.55 V. Accuracy is ± 3 percent of nominal value over the specified operating temperature and voltage ranges.

TX Bias Current in mA: Represented as a 16-bit unsigned integer with current defined as the full 16-bit value (0 – 65535) with LSB equal to 2 uA with a measurement range of 0 – 131 mA. Accuracy is ± 10 percent of nominal value over the specified operating temperature and voltage ranges.

TX Output Power in mW: Represented as a 16-bit unsigned integer with the power defined as the full 16-bit value (0 – 65535) with LSB equal to 0.1 uW. Accuracy is ± 2 dB over the specified temperature and voltage ranges over the range of -8.4 dBm to -3.0 dBm. Data is not valid when transmitter is disabled.

RX Received Optical Power in mW: Represented as average power as a 16-bit unsigned integer with the power defined as the full 16-bit value (0 – 65535) with LSB equal to 0.1 uW. Accuracy is ± 3 dB over the specified temperature and voltage ranges over the power range of -19 dBm to 1.0 dBm.

Reading the data

The information is accessed through the SCL and SDA connector pins of the module. The specification for the EEPROM contains all the timing and addressing information required for accessing the data.

The device address used to read the Serial ID data is 1010000X(A0h), and the address to read the diagnostic data is 1010001X(A2h). Any other device addresses will be ignored.

MOD_ABS, pin 6 on the transceiver, corresponds to MOD – DEF(0), and it is connected to Logic 0 (ground) on the transceiver.

10

MOD - DEF(1), pin 5 on the transceiver, is connected to the SCL pin of the Management Processor/EEPROM.

MOD - DEF(2), pin 4 on the transceiver, is connected to the SDA pin of the Management Processor/EEPROM.

The EEPROM Write Protect pin is internally tied to ground with no external access, allowing write access to the customer-writable field (bytes 128 – 247 of address 1010001X). Note: address bytes 0 – 27 are not write protected and may cause diagnostic malfunctions if written over.

Decoding the data

The information stored in the EEPROM, including the organization and the digital diagnostic information, is defined by SFF-8472 Revision 10.4, dated January 30, 2009.

Data Field Descriptions

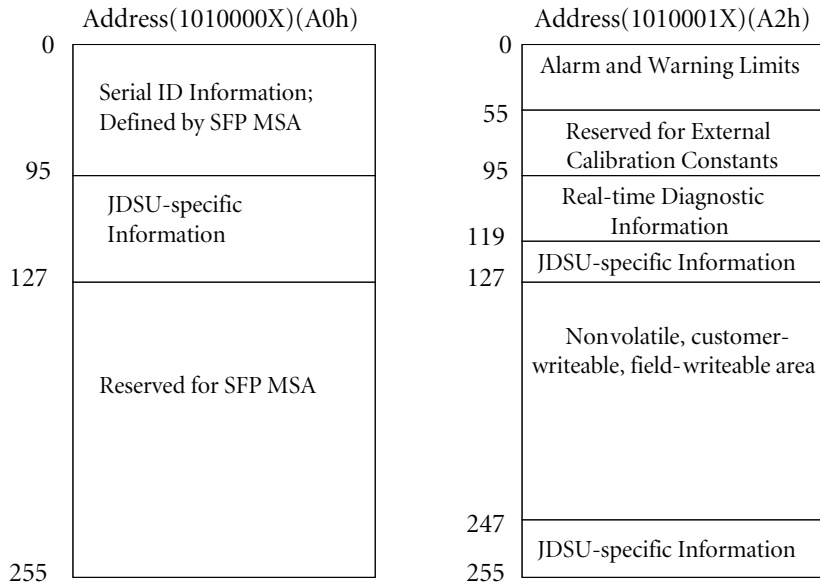

11

Serial ID Data and Map

Memory Address	Value	Comments
Address (1010000X)(A0h)		
0	03	SFP Transceiver
1	04	SFP with Serial ID
2	07	LC Connector
3-10	000000020A000115	1310 nm singlemode, 100/200/400 FC, Medium and Long Distance and 1000Base-LX
11	01	8B/10B encoding mechanism
12	2B	Nominal Bit rate of 4Gbps
13	00	Reserved
14	05	Single mode fiber, 5 km distance
15	32	Single mode fiber, 5 km in units of 100 m
16	00	50/125 μ m fiber not supported
17	00	62.5/125 μ m fiber not supported
18	00	Copper not supported
19	00	Reserved
20-35	JDSU	Vendor Name (ASCII)
36	00	Reserved
37-39	00019C	IEEE Company ID (ASCII)
40-55		Part Number (ASCII)
56-59		Rev of part number (ASCII)
60-61	051E	Wavelength of laser in nm; 1310
62		Reserved
63		Check Code; Lower 8 bits of sum from byte 0 through 62
64	00	Reserved
65	3A	Rate Select, Tx_Disable, Tx Fault, Loss of Signal implemented
66	05	Bit rate, Maximum, in units of 1% above nominal
67	4E	Bit rate, Minimum, in units of 1% below nominal
68-83		Serial Number (ASCII)
84-91		Date Code (ASCII)
92	68	Digital diagnostics monitoring implemented, internally calibrated, receiver power type is average
93	F8	Alarms & Warnings, TX_Fault and Rx_LOS monitoring implemented, TX_Disable Control & Monitoring. Soft rate select control & monitoring implemented.
94	03	SFF-8472 Rev 10.2 compliant
95	64_94	Check Code; Lower 8 bits of sum from byte 64 through 94
96-127		JDSU specific EEPROM
128-255		Reserved

12

Diagnostics Data Map

Memory Address	Value	Comments
Address (1010001X)(A2h)		
00-01	Temp High Alarm	MSB at low address
02-03	Temp Low Alarm	MSB at low address
04-05	Temp High Warning	MSB at low address
06-07	Temp Low Warning	MSB at low address
08-09	Voltage High Alarm	MSB at low address
10-11	Voltage Low Alarm	MSB at low address
12-13	Voltage High Warning	MSB at low address
14-15	Voltage Low Warning	MSB at low address
16-17	Bias High Alarm	MSB at low address
18-19	Bias Low Alarm	MSB at low address
20-21	Bias High Warning	MSB at low address
22-23	Bias Low Warning	MSB at low address
24-25	TX Power High Alarm	MSB at low address
26-27	TX Power Low Alarm	MSB at low address
28-29	TX Power High Warning	MSB at low address
30-31	Tx Power Low Warning	MSB at low address
32-33	RX Power High Alarm	MSB at low address
34-35	RX Power Low Alarm	MSB at low address
36-37	RX Power High Warning	MSB at low address
38-39	RX Power Low Warning	MSB at low address
40-55	Reserved	
56-59	Rx_PWR(4) = 0 for internally calibrated	External Calibration Constant
60-63	Rx_PWR(3) = 0 for internally calibrated	External Calibration Constant
64-67	Rx_PWR(2) = 0 for internally calibrated	External Calibration Constant
68-71	Rx_PWR(1) = 0 for internally calibrated	External Calibration Constant
72-75	Rx_PWR(0) = 0 for internally calibrated	External Calibration Constant
76-77	Tx_I(Slope) = 1 for internally calibrated	External Calibration Constant
78-79	Tx_I(Offset) = 0 for internally calibrated	External Calibration Constant
80-81	Tx_PWR(Slope) = 1 for internally calibrated	External Calibration Constant
82-83	Tx_PWR(Offset) = 0 for internally calibrated	External Calibration Constant
84-85	T(Slope) = 1 for internally calibrated	External Calibration Constant
86-87	T(Offset) = 0 for internally calibrated	External Calibration Constant
88-89	V(Slope) = 1 for internally calibrated	External Calibration Constant
90-91	V(Offset) = 0 for internally calibrated	External Calibration Constant
92-94	Reserved	Reserved
95	Checksum	Bytes 0_94
96	Temperature MSB	Internal temperature
97	Temperature LSB	
98	Vcc MSB	Internally measured supply voltage
99	Vcc LSB	
100	TX Bias MSB	Internally measured TX bias current
101	TX Bias LSB	
102	TX Power MSB	Measured TX output power
103	TX Power LSB	
104	RX Power MSB	Measured RX input power
105	RX Power LSB	
106	Reserved MSB	For 1st future definition of digitized analog input
107	Reserved LSB	
108	Reserved MSB	For 2nd future definition of digitized analog input
109	Reserved LSB	
110	Optional status/control bits	Refer to SFF-8472 Rev 10.2 for description of features

13

Diagnostics Data Map	(continued)
-----------------------------	-------------

Memory Address	Value	Comments
Address (1010001X)(A2h)		
111	Reserved	Reserved
112-119	Optional alarm & warning flag bits	Refer to SFF-8472 Rev 10.2 for description of features
120-127	Vendor specific	Vendor specific
128-247	User/Customer EEPROM	Field writeable EEPROM
248-255	Vendor specific	Vendor specific

Package and Handling Instructions

Process plug

The JSH-42L4DD1 is supplied with a dust plug that protects the transceiver optics during standard manufacturing processes by preventing contamination from air borne particles.

Note: It is recommended that the dust cover remain in the transceiver whenever an optical fiber connector is not inserted.

Flammability

The JSH-42L4DD1 housing is made of cast zinc and sheet metal.

Electrostatic Discharge (ESD)

Handling

Normal ESD precautions are required during the handling of this module. This transceiver is shipped in ESD protective packaging. It should be removed from the packaging and handled only in an ESD protected environment utilizing standard grounded benches, floor mats, and wrist straps.

Test and operation

In most applications, the optical connector will protrude through the system chassis and be subjected to the same ESD environment as the system. Once properly installed in the system, this transceiver should meet and exceed common ESD testing practices and fulfill system ESD requirements.

Typical of optical transceivers, this module's receiver contains a highly sensitive optical detector and amplifier that may become temporarily saturated during an ESD strike. This could result in a short burst of bit errors. Such an event might require the application to reacquire synchronization at the higher layers (serializer/deserializer chip).

Electromagnetic Interference (EMI) and Immunity

To assist customers in managing overall equipment EMI performance, these transceivers are compatible with the industry-standard SFP cage, which provides protection for EMI emission and EMI susceptibility. All transceivers comply with FCC Class B limits.

Eye Safety

The JDSU JSH-42L4DD1 1310 nm, laser-based transceivers are Class 1 laser products. They conform to FDA regulations 21 CFR 1040.10 and 1040.11 laser safety requirements, including deviations pursuant to Laser Notice No. 50, dated July 26, 2001. They are also certified to comply with IEC standards 60825-1, 60825-2, and 60950, as well as CDRH. The transceivers are eye safe when operated within the limits of these specifications.

Operating this product in a manner inconsistent with intended usage and specification may result in hazardous radiation exposure.

Caution

Tampering with this laser based product or operating this product outside the limits of this specification may be considered an act of manufacturing, and will require, under law, recertification of the modified product with the U.S. Food and Drug Administration (21 CFR 1040).

The use of optical instruments with this product will increase eye hazard.

Ordering Information

For more information on this or other products and their availability, please contact your local JDSU account manager or JDSU directly at 1-800-498-JDSU (5378) in North America and +800-5378-JDSU worldwide, or via e-mail at customer.service@jdsu.com.

Product Code	Description
JSH-42L4DD1	4.25, 2.125, 1.25 and 1.063 Gbps, 1310nm SFP Transceiver, 5 km, single mode, FP, -40 to 85°C, RoHS compliant

NORTH AMERICA: 800 498-JDSU (5378)

WORLDWIDE: +800 5378-JDSU

WEBSITE: www.jdsu.com