

HST-3000

E1/Datacom Service Interface Module (SIM)



Key Features

- **Datcom (X.21, V.24 (RS232), V.35, V.36 (RS449), EIA530)**
- **G.703: 2 Mb/s Testing**
- **2 RX/2 TX: E1 Interfaces**
- **Bulk, n x 64 kb/s BERT**
- **G.821, G.826, M.2100**
- **Audio Monitor**
- **Signal Level and Frequency**
- **Round-Trip Delay**
- **Event Log and Histograms**
- **Pulse Shape**
- **Frame Relay**

The JDSU HST-3000 E1/Datacom Service Interface Module (SIM) delivers the full functionality required for technicians tasked with ensuring and delivering high quality of service (QoS) for E1/Datacom. Part of a comprehensive catalog of modules for the HST-3000 platform, the E1/Datacom SIM provides the complete range of installation, maintenance, and troubleshooting features needed for E1/Datacom circuits and network elements.

Rugged, versatile, and portable, the HST-3000 is the ideal field instrument to test the complete circuit—from the customer premises through the entire network—by analyzing the performance of the digital link in both directions. It also can verify operation or locate network problems by generating bit error rate test (BERT) patterns and by testing frame relay service. In addition to testing the physical circuit, the HST can test the service and the application. The modular plug-in hardware and software architecture can be scaled to test copper, ADSL, ADSL2+, G.SHDSL, IP, Ethernet, VoIP, and IP Video.

Workgroups can rely on this functionality as networks migrate from circuit- to packet-switched infrastructures that support the triple play of voice, video, and data over Ethernet. The HST-3000 is an efficient, economical tool service providers can rely on to simplify processes, expedite task completion, and ensure reliable E1 and Datacom service delivery.

Functional Overview

Dual E1 RX/TX

Two separate receivers (RX) and transmitters (TX) allow for the simultaneous monitoring and evaluation of a wide range of alarms and errors. Different test modes with clock preferences support all of the requirements for ITU-T G.703 frame analysis, BERT, ITU-T G.821, ITU-T G.826, and ITU-T M.2100, which enables operators to validate connectivity and QoS quickly and efficiently.

E1 Pulse Shape Option

Incorrect pulse shape, due to jitter or incorrectly terminated interfaces, causes poor network performance. The Pulse Shape software option quickly assists in identifying network problems during installation, commissioning, or troubleshooting by comparing the pulse with the ITU-T G.703 pulse mask. The software averages the received E1 pulse and automatically displays the result against the ITU-T mask.

Frame Relay Option

With the Frame Relay software option, technicians can verify that frame relay service is functioning properly by testing Layer Management Interface (LMI) activity, Permanent Virtual Circuit/Data Link Connection Identifier (PVC/DLCI) status, congestion, and lost frames to validate committed information rates (CIR).

Bidirectional Monitoring

The HST-3000 can monitor transmission passively in both directions to confirm physical layer and service level results on E1/Datacom circuits.

Timing Analysis

When using synchronous timing, the receiving device must be properly synchronized to the clock signal, or misinterpretation of bits can cause bit errors and timing slips. The HST-3000 provides internal source options and an external clock adapter cable, allowing technicians to diagnose and correct network timing problems rapidly.

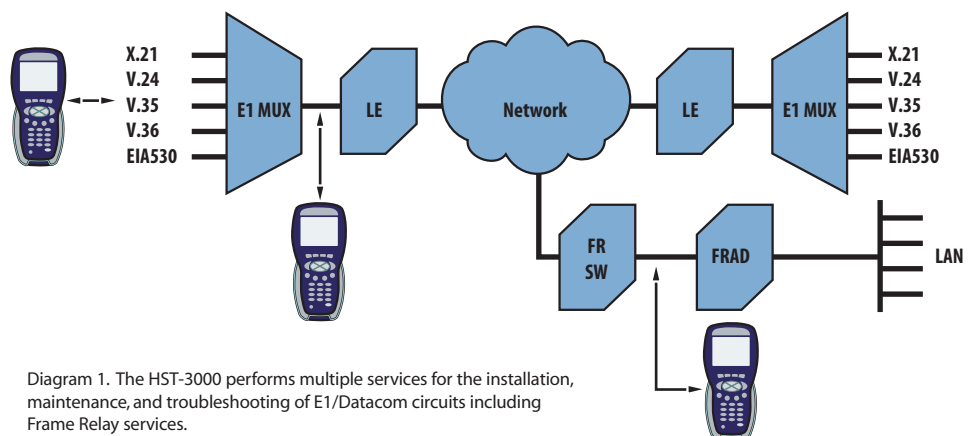

Diagram 1. The HST-3000 performs multiple services for the installation, maintenance, and troubleshooting of E1/Datacom circuits including Frame Relay services.

Datacom DTE/DCE Emulation

The HST-3000 can replace either a data terminal equipment (DTE) or data circuit-terminating equipment (DCE) device and can test head-to-head with existing network elements. Emulating the customer premises equipment (CPE) enables technicians to control handshaking states between DTE and DCE devices to ensure proper transitions and to verify connectivity. Technicians can sectionalize problems in the network by qualifying proper data transmissions and signaling states.

Traffic Generation

With the HST-3000, technicians can send BERT patterns to verify error-free performance by transmitting ANSI, ITU, and user-programmable test patterns. They can test head-to-head with other JDSU equipment or via loopback mechanisms. Performance measurements such as Round-Trip Delay, G.821, G.826, and M.2100 allow technicians to verify that all circuit parameters fall within the required level of performance.

Verify End-to-End Connectivity

Technicians can quickly isolate any problem to a specific direction by analyzing the performance of the entire digital link in both directions. After the circuit is installed, the HST-3000 can be used to qualify proper channel routing, delay, and performance over the entire link.

Auto Configure

The Auto Configure feature greatly simplifies instrument setup. For a framed signal, the HST-3000 can determine the framing and test pattern types.

Programmable Timers

The HST-3000 can be programmed to start a delayed test at a specific date and time for a selected duration.

Self-Loop Testing

The HST-3000 provides an internal Datacom self-loop testing feature that connects the transmitter to the receiver without involving external cables. This feature allows technicians to validate the unit settings and the selected test interface on the HST-3000. An external cable test feature verifies both the amplifiers and the current emulation cable.

User-Configurable Set-up

Technicians can select and configure the test interface, timing mode, timing source, data rate, flow control, and test pattern on the HST-3000. In addition to standard software LED result pages, the HST-3000 contains user-defined hardware Datacom LEDs on the module, displaying signal states.

Saved Results

The HST-3000 can save hundreds of results that can be exported directly to a printer or a PC via serial, Ethernet, or USB ports, which can then be e-mailed, printed, or saved onto a PC or USB device.

VT100 Emulation

With the HST-3000 VT100 emulation feature, technicians can access E1 and HDSL network equipment for configuration, performance data measurements, and loopback capabilities without having to carry a PC or laptop into the field.

Flexible and Rugged Design

The HST-3000 incorporates a rugged, weather-resistant design and long battery life that are ideally suited for use in the field. Standard Ethernet, USB, and serial ports offer flexibility for easily downloading software and offloading captured test data. Highly configurable, technicians with differing responsibilities can use the HST-3000 to perform a wide variety of tests. The HST-3000 is based on a modular platform, allowing for the addition of upgrades and options in the field. This flexibility also allows for the support of future growth in new technologies and advanced options to accommodate the changing needs of versatile technicians.

Specifications

Physical Interfaces**Transmitters to G.703**

Outputs	2 x balanced RJ48 jacks Impedance 120 Ω Unbalanced / 75 Ω via adapter cables
Bit Rate	2048 kbit/s, ±3 ppm, +1 ppm per year aging
Line Code	HDB3 or AMI
Frequency Offset	±100 ppm in 1 ppm intervals
Slip Reference	Opposite RX, External E1 Reference Clock
Clock Source	Internal, Recovered from RX1 or RX2, External E1 Reference Clock (via optional cable)

Receivers to G.703

Inputs	2 x balanced RJ48 jacks Impedance 120 Ω or bridged (hi-Z) Unbalanced/ 75 Ω via adapter cables
PMP Compensation	20 to 31 dB gain
Bit Rate	2048 kbps
Level Measurement	+3 to -37 dBnom
Slip Reference	Opposite RX, External E1 Reference Clock
External E1 Reference Clock	0.5 to 3 V square or sine wave, 2,048 MHz, unbalanced/ 75 Ω (at adapter cable input)

Datacom Port

Interfaces supported (via adapter cables)	X.21, V.24 RS232, V.35, V.36 RS449, EIA530
--	---

E1 Circuit Testing

Framed and unframed test signal generation
Bulk, n x 64 kbit/s BERT
G.821, G.826, M.2100 analysis
Error and alarm and generation and analysis
Round-Trip Delay
Signal Level and Frequency
Audio Monitor

Si, Sa, A-bit, and E-Bit (REBE) monitoring and generation

Test Modes

Terminate, Monitor, Drop and Insert, Line Loopback

Performance Measurement

G.821, G.826, M.2100

Test Patterns

2⁶-1 (ITU), 2⁹-1 (ITU), 2¹¹-1 (ITU), 2¹⁵-1
(ITU & ITU INV), 2²⁰-1 (ITU & ITU INV),
2²³-1 (ITU & ITU INV), QRSS, QBF
Mark (All Ones), Space (All Zeros), 1:1, 1:3, 1:4, 1:7

User Bit Patterns 3 to 32 bits

User Byte Patterns 1 to 64 bytes

Live

Delay

Auto (via Auto Configure)

Anomaly (Error) Injection

Bit (TSE)	Single, rate, multiple
Code, CRC, Pattern Slip, E-Bit (REBE)	Single

FAS	Single, 2, 3, 4
MFAS	Single, 2

Defect (Alarm) Generation

LOS, LOF, AIS, RDI/FAS distant, MF AIS (TS-16), MF RDI/MFAS distant

Anomaly (Errors) Counts

Bit (TSE), Code, FAS, MFAS, CRC, E-Bit

Frame Data

Sa4, Sa5, Sa6, Sa7, Sa8, NFAS A-Bit, NMFA

Signal Results

Signal loss (seconds), bit slips, RX level, TX and RX bit rate

BERT Results

Bit errors (TSE), bit error rate, errored seconds, error-free seconds, percentage error-free seconds, pattern slip, round-trip delay, pattern loss seconds (LFF)

Audio Monitor

From RX1, RX2, or RX1 and RX2

Round-Trip Delay

Range	0-10 s
Resolution	100 μs

Result Categories

Summary, LED, Signal, Frame Data, Timeslot, BERT, Performance (G.821, G.826 ISM, G.826 OOS, M.2100 ISM, M.2100 OOS), Time, Event Table, Event Log, Event Histogram

Datacom Circuit Testing**Interfaces**

Via adapter cables	X.21, V.24 RS232, V.35, V.36 RS449, EIA530
--------------------	---

Data Rates (Emulate and Monitor)

X.21	Sync 50 bps to 10 Mbps
V.24 RS232	Async 50 bps to 128 kbps
V.24 RS232	Sync 50 bps to 128 kbps
V.35	Sync 50 bps to 2048 kbps
V.36 RS449	Sync 50 bps to 10 Mbps
EIA430	Sync 50 bps to 10 Mbps

Datacom**BERT Patterns**

Mark (All Ones), Space (All Zeros), 1:1, 1:3, 1:4, 1:7, 3:1, 7:1, 63, 511, 2047, 2047R, 2047R INV, 2¹⁵-1 (ANSI, ITU), 2²⁰-1 (ANSI, ITU), 2²³-1 (ANSI, ITU), QRSS, QBF1 (FOX), QBF (2,3), User Bit, User Byte, Delay

Transmit Clock Sources

Internal ±3 ppm, 1 ppm per year aging

Interface

Signaling Lead Control

Emulate DTE

RTS, DTR, LL, RL

Emulate DCE

CTS, DSR, DCD, TMA

Monitor

Self Loop

Internal

External Cable Test

Result Categories

Summary, Signal, BERT, Data, LED, Data LED, Control LED, G.821, Time, Event Table, Event Histogram

Specifications Cont'd

Pulse Shape Analysis**Results**

Pulse Shape Graph G.703 mask for E1

Pulse Width

Resolution 2.75 ns

Rise Time In [ns]

Resolution 1 ns

Fall Time In [ns]

Resolution 1 ns

Undershoot Percent of nominal level

Resolution 1%

Overshoot Percent of nominal level

Resolution 1%

Signal Level In [V] peak-peak

Pass/Fail Indication Pass/Fail

Result Categories

Summary, Signal, Interface, Frame Data, BERT, Pulse Shape

Frame Relay

Test Modes Terminate and Monitor (UNI-U, UNI-N, NNI)

Link Management None, ANSI T1.617 Annex D,

ITU Q.933 Annex A, LMI Rev 1, Auto

DLCI 0-1023

Link Trace Simple, Verbose, Text, Hex, Text & Hex

Long Frame 5-9999

Load Test

Test of CIR (load) Off, Fixed, Burst, Ping

CIR Fixed Rate 1-10,000 kbps

Frame Lengths 5-9999

Payload Sequence, User 1, User 2, Sequence + User

Control Bits FECN, BECN, DE, C/R

Burst Settings TX time, Idle time

FR CRC error, plus E1 or

Datacom Anomaly (Error)/Defect (Alarm)

Ping

Settings Source IP Address, Destination IP Address,

Inverse ARP, Ping Length

Encapsulation NLPID, Ethertype

Result Categories

Frame Relay (DLCI, Link, Ping, LMI, DLCI List, Trace), plus E1 and Datacom

Physical

Size (H x W x D) 241 x 114 x 70 mm

(9.5 x 4.5 x 2.75 in)

Weight (with battery) 1.23 kg (2.7 lb)

Operating temperature 5.5 to 50°C (22 to 122°F)

Storage temperature -40 to 65.5°C

(-40 to 150°F)

Battery life 10 hrs. typical usage

Charging time 7 hrs. from full discharge

to full charge

Operating humidity 10 to 80% relative humidity

Storage humidity 10 to 95% relative humidity

Display 3.8" diagonal, 1/4 VGA, Color Active Matrix with backlight (readable in direct sunlight)

General

Ruggedness Survives 91 cm (3 ft) drop to concrete

on all sides

Water-resistant Splashproof

(may be used in heavy rain)

Languages English, German, French, Spanish, Italian,

Chinese, Turkish

Keypad Typical 12-button keyboard

Ordering Information

Base Unit

HST3000-NG	HST-3000 Mainframe without Copper (Color)
HST3000C-NG	HST-3000 Copper Mainframe (Color)

Available SIMS (Modules)

HST3000-CUCE	Copper only SIM, CE Marked
HST3000-AR2A-T1	ADSL2+ T1 (ATU-R, Annex A)
HST3000-AR2A	ADSL1/2/2+ (ATU-R, Annex A)
HST3000-AR2B	ADSL1/2/2+ (ATU-R, Annex B)
HST3000-AR2B-T1	ADSL2+ T1 (ATU-R, Annex B)
HST3000-CAR2A	ADSL1/2/2+ with Copper (ATU-R, Annex A)
HST3000-CAR2A-T1	Copper, ADSL2+ T1 (ATU-R, Annex A)
HST3000-CAR2B	ADSL1/2/2+ with Copper (ATU-R, Annex B)
HST3000-CAR2B-T1	Copper, ADSL2+ T1 (ATU-R, Annex B)
HST3000-CARB	Annex B Copper/ATU-R
HST3000-CARCA	Copper and ATU-R/C Dual Mode, AoPOTS
HST3000-CARCB	Copper and ATU-R/C Dual Mode, AoISDN
HST3000-CARCE	Copper and ATU-R (Annex A), CE Marked
HST3000-WB2	Wide Band 2 (up to 30 MHz) Copper Test
HST3000-VDSL-CNXT	VDSL with Conexant Chipset
HST-3000-VDSL-CNXT-WB2	VDSL and Copper (up to 30 MHz) with Conexant Chipset
HST3000-VDSL-IK	VDSL with Ikanos Chipset
HST-3000-VDSL-IK-WB2	VDSL and Copper (up to 30 MHz) with Ikanos Chipset
HST3000-INF-VDSL	VDSL with Infineon Aware Chipset
HST-3000-INF-VDSL-WB2	VDSL and Copper (up to 30 MHz) with Infineon Aware Chipset
HST3000-ETH	10/100/1000 Ethernet
HST3000-CT1	T1 and Copper
HST3000-DC	Datacom
HST3000-E1	E1
HST3000-E1-DC	E1/Datacom
HST3000-4WLL	4-Wire Local Loop
HST3000-T1	Dual TX/RX Bantam T1 Interface and T1
HST3000-T3	Dual TX/RX Bantam T1 Interface, and Dual RX/Single TX BNC DS3 Interface/and DS3
HST-BRA	ETSI (Euro) ISDN BRA
HST3000-BRI	ISDN BRI
HST3000-CSHCE	G.SHDSL and Copper
HST-GSH	G.SHDSL
HST3000-GSHCE	2-Wire G.SHDSL
HST3000-CSH4	Copper, 4-Wire G.SHDSL (STU-R/C, Annex A/B)
HST3000-BLK	Blank

Software Options

HST3000-BLUETOOTH	Bluetooth Wireless
HST3000S-WEB	Web Browser
HST3000-REMOP	Remote Operation
HST3000-SCRIPT	Scripted Test
HST3000-DSL2	ADSL2 and ADSL2+
HST3000S-IP	Advanced IP Suite—PING and Through Mode Support
HST3000S-IP-Video	IP Video Analysis
HST3000S-VMOS	Video MOS Analysis
HST3000-MSTV	Microsoft IPTV Video Analysis
HST3000-VT100	VT100 Emulation
HST3000S-VOIP	VoIP Software Analysis
HST3000S-H.323	H.323 VoIP Signaling
HST3000S-MGCP	SCCP MGCP VoIP Signaling
HST3000S-MOS	VoIP Mean Opinion Score
HST3000S-SCCP	SCCP VoIP Signaling
HST3000S-SIP	SIP VoIP Signaling
HST3000-UNISTIM	VoIP Signaling Call Controls for UNISTIM
HST3000-OPTETH	Optical Ethernet
HST3000-IPV6	IPv6
HST3000-MPLS	MPLS
HST3000-MSTR	Multiple Streams
HST3000-TCPUDP	TCP/UDP
HST3000-FTP	FTP
HST3000-WBTONES	WB TIMS
HST3000-PCMTIMS	TIMS (PCM)
HST3000-PCMSIG	Signaling (PCM)
HST3000-SPE	Spectral Noise
HST3000-RFL	RFL
HST3000-TDR	TDR
HST3000-PRI	ISDN PRI (NC Standard)
HST3000-ST	Basic Rate ISDN S/T (ANSI)
HST3000-T1DDS	DDS-T1
HST3000-TxIMP	Transmission Impairments
HST3000-FR	Frame Relay
HST3000-PS	Pulse Shape



Test & Measurement Regional Sales

NORTH AMERICA TEL: 1 866 228 3762 FAX: +1 301 353 9216	LATIN AMERICA TEL: +1 954 688 5660 FAX: +1 954 345 4668	ASIA PACIFIC TEL: +852 2892 0990 FAX: +852 2892 0770	EMEA TEL: +49 7121 86 2222 FAX: +49 7121 86 1222	www.jdsu.com/test
---	--	---	---	---