

TrueLength™ Cable Length Meter

User's Guide

www.jdsu.com/know

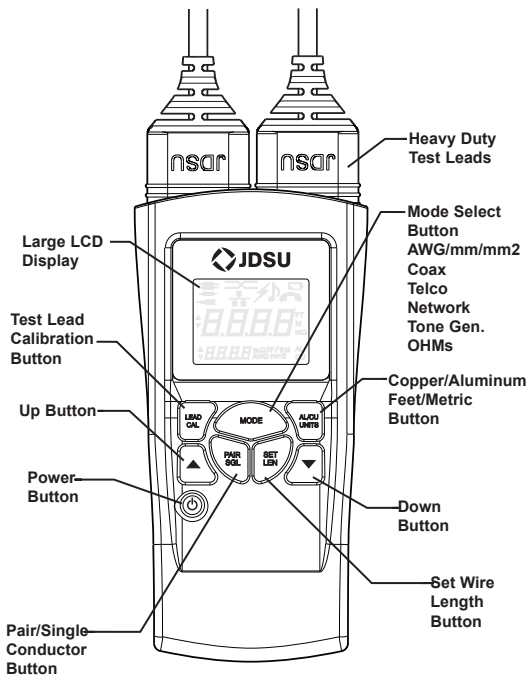



TrueLength Cable Length Meter
CLM400



Warning

*Do not attach test leads to energized cables.
The TrueLength unit may be damaged.*

Description

The TrueLength cable length meter is an easy-to-use, versatile compact handheld unit for measuring cable length and generating tone. TrueLength works on virtually any single or two conductor cables for testing and troubleshooting.

Key Features

- Measure distance to open or distance to short
- Modes of operation: AWG/mm/mm², Telco, Network, Coax, Tone Generator and Ohms
- Single or dual (pair) conductor length measurements in feet or meters
- Audible indicator for shorted wires
- Large LCD, easy-to-read under sunlight
- Measures wires 8 to 30 AWG (3.264mm /8.366 mm² to 0.255mm/0.051 mm²)
- Copper (CU) or Aluminum (AL) wire measurements
- 120vac Voltage Protection
- 12 pre-set wire gauge settings
- 12 user programmable wire gauge settings
- 4 selectable tones
- Requires 9 volt battery (not included)
- Auto shut down
- Resistance 0 to 635 Ohms
- Opens/Capacitance 0 to .082uf (approx. 5K feet)
- Measurements at milliohm resolution
- CE certified

General Functions

PWR Key and Auto Power Off

Turn the unit on and off. TrueLength powers off automatically after 10 minutes, if no keys have been depressed. The timer is reset every time a key depression has been detected. **In Tone Mode unit will automatically power down after 1 hour.**

MODE Key

TrueLength provides eight modes of operation, depressing the “**MODE**” key will cycle through the various modes:

- **AWG/mm/mm²** - Measures Cable Length in AWG/mm/mm², feet/meters, Copper/Aluminum
- **COAX** - Measures cable length, distance to opens or distance to short
- **TELCO** - Measures cable length, distance to opens or distance to short
- **NETWORK** - Measures cable length, distance to opens or distance to short
- **OHMS** - Measures 0 to 635 ohms
- **TONE** - Generates 4 different unique tones









AL/CU UNITS Key

Key has a dual function.

Function 1: The user can select wire alloy type copper (CU) or aluminum (AL) by pressing the “**AL/CU/UNITS**” key (toggle) normally. The “AL” or “CU” icon will illuminate in the lower right corner of the display as selected.

Function 2: Holding the “**AL/CU/UNITS**” key down approximately 1.5 seconds, the unit will toggle between units of measure “Feet” or “Meters”. The “M” or “FT”, icon will illuminate in the center right hand side of the screen as selected.

LCD Display Icons

Feature	Description
	Coax Mode
	Telco Mode
	Network Mode
	Tone Mode
	Dual Conductor icon (AWG/mm/mm2 Mode)
	Single Conductor icon (AWG/mm/mm2 Mode)
	Short Symbol, indicates the presence of a short between two conductors. An Audible Tone will also be generated. (Coax, Telco, and Network Mode)
	Indicate unit has detected the presence of voltage on the line.
	Battery Low Icon. TrueLength monitors battery status continuously when it is powered on. When the battery low icon is activated, the unit has approximately 15 minutes of battery life. The battery should be replaced as soon as possible. Cable testing results will become unreliable if the 15 minute period is exceeded

Instructions for Use

AWG Mode

This mode allows length measurements, in the range of 8 to 30 AWG (8, 10, 12, 14, 16, 18, 20, 22, 24, 26, 28 and 30). Using the UP/DOWN keys, the user can scroll through the various wire gauges. The user can select from copper or aluminum type wires and meters or feet. Figure 1, shows a typical AWG screen shot.

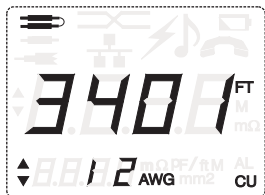

Figure 1

AWG/mm/mm2 cross Reference table

A.W.G.	Diameter (mm)	Area (mm ²)
#8	3.264	8.37
#9	2.906	6.63
#10	2.588	5.26
#11	2.305	4.17
#12	2.053	3.31
#13	1.828	2.62
#14	1.628	2.08
#15	1.450	1.65
#16	1.291	1.31
#17	1.150	1.04
#18	1.024	0.823
#19	0.912	0.653
#20	0.812	0.518
#21	0.723	0.410
#22	0.644	0.326
#23	0.573	0.258
#24	0.511	0.205
#25	0.455	0.162
#26	0.405	0.129

#27	0.361	0.102
#28	0.321	0.081
#29	0.286	0.064
#30	0.255	0.051

PAIR SGL Key

TrueLength can measure single or dual conductor wires. Depressing the “PAIR SGL” key toggles between single or dual conductor. Single conductor measurements assume the unit is connected at both ends of the wire/conductor. In AWG/mm/mm² mode dual conductor measurements assume the user is measuring at one end of the wire, while the other end of the pair is shorted (wire length = total resistance / 2).

SET LEN Key (AWG Mode example)

The Set Length function allows the user to change factory default values, ohms per feet coefficients, based on a sample length of wire. The “**SET LEN**” key serves as a dual function when depressed normally, it will toggle between AWG mode screen (figure 1) and Set Length mode screen (figure 2). In Set Length mode, the unit will measure the resistance of the sample wire. The length of wire can be set by adjusting the “**UP/DOWN**” keys in the range of 100 to 200 feet. The smaller digits display ohms per feet, based on the sample wire. Holding the “**SET LEN**” key down for a few seconds will store the new coefficients overriding factory default values.

Example: The factory default for 12 AWG Copper is .0017 Ω per feet.

- 1) Using the “**MODE**” key, select AWG mode and set the AWG to 12 using the “**UP/DWN**” keys.

Depress the “**SET LEN**” (LEN = Length) key, a new screen will pop up (see Figure 2). In this mode the “**UP/DOWN**” keys are used to adjust the larger digits to match the length of the sample wire (100 – 200 ft range). Assume the sample wire is 150 feet and its resistance is equal to .315 ohms. The smaller digits on the left hand side of the screen will display “002.1m Ω ” (Ω per feet).

- 1) To store the new value, depress the “**SET LEN**” key down approximately 1.5 seconds, a confirmation beep will be generated. The new 12AWG length coefficient of .0021 Ω per feet will be stored in memory in place of the factory default of .0017 Ω per feet.

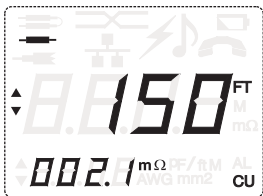

Figure 2

*Note: Restoring Factory Default Values.
To restore factory coefficients back to its original values, hold the “**UP/DOWN**” keys and the **Power**” key down at the same time when powering down the unit. Any previous values stored by the user will be deleted from memory.*

AWG	Aluminum	Copper
8	.00103	.00063
10	.00164	.0011
12	.00261	.0017
14	.00414	.0025
16	.00659	.00455
18	.0105	.0061
20	.0167	.00945
22	.0265	.0168
24	.0421	.0273
26	.067	.0436
28	.106	.0637
30	.169	.108

Table 1
Factory Default
Values, Ohms per Feet

COAX, NETWORK, TELCO Mode

Coax (See Figure 5 for coax F connection measurements), Network and Telco modes detect distance to opens and distance to shorts. Figure 3, shows a Network screen shot (line open).



Figure 3

TrueLength determines length by measuring line capacitance when the line is open or measuring resistance when the line is shorted. Measuring opens, the user can adjust the capacitance coefficient (10 to 40pf per feet) to calculate the cable length by using the “**UP/DOWN**” keys. TrueLength supports three user-adjustable length coefficients, one for each type of cable (Coax, Network and Telco). TrueLength stores these coefficients in memory even when the unit is powered off.

Short/Resistance coefficients are stored in memory (see Table 2 for factory default values). These values can be changed by running the Set Length Function.

The Set Length function allows the user to change factory default values, ohms per feet coefficients, based on a sample known length of wire. The “**SET LEN**” key serves as a dual function. When depressed normally it will toggle between figure 3 (normal measuring screen) and Set Length mode screen, figure 4. In Set Length mode (line shorted), the unit will measure the resistance of the sample wire. The length of the sample wire can be set adjusted by the UP/DOWN keys in the range of 100 to 200 feet. The smaller digits display the ohms per feet based on the sample wire. Holding the “**SET LEN**” key down for a few seconds will store the new coefficients.

Example: The factory default for Network wire is .0273 Ω per feet.

- 1) Using the “**MODE**” key, select Network mode.
- 2) Depress the “**SET LEN**” (LEN = Length) key, a new screen will pop up (see figure 4). In this mode the “**UP/DOWN**” keys are use to adjust the larger digits to match the length of the sample

wire (100 – 200 ft range). Assume the sample wire is 150 feet and its resistance is equal to .315 ohms. The smaller digits on the left hand side of the screen will display “002.1mΩ”.

- 3) To store the new value, depress the “**SET LEN**” key down approximately 1.5 seconds, a confirmation beep will be generated. The new Network length coefficient of .0021Ω per feet will be store in memory.

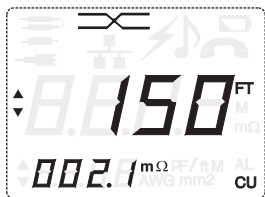

Figure 4

Note: Restoring Factory Default Values To restore ohms per feet factory coefficients back to its original values, hold the Power and UP/DOWN keys down at the same time when powering down the unit. Any previously stored values by the user will be overwritten to factory default.

In order to obtain symmetrical test results for Shorts and Opens measurements the TrueLength must have the correct “capacitance per feet coefficient” and “resistance per feet coefficient” of the wire under test.

Changing Opens/Capacitance Coefficient using Set Length.

Changing capacitance coefficients can also be accomplished by following the steps above (Cable/wire must be open) based on the sample wire (100 to 200 ft). TrueLength measures the total capacitance of the cable and displays the value in the lower left hand corner of the LCD (cable must be within 10 to 40pf per feet range, otherwise meter will indicate OL).

Mode	Capacitance Opens	Ω per feet / AWG shorts
Coax	22.0pf	.0663 Ω / NA
Network	15.0pf	.0273 Ω / 24 AWG
Telco	17.5pf	.0273 Ω / 24 AWG

Table 2
Factory Default Values

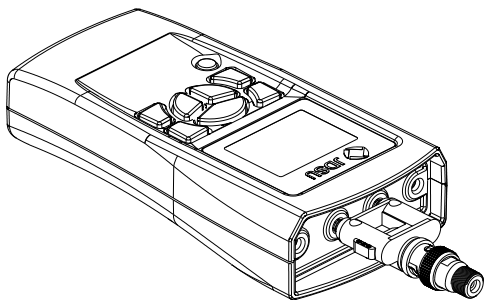

Figure 5.
BNC to F connection for Coax
measurements.

TONE Mode

To generate a tone on the cable/wire, select Tone Mode (see figure 6). TrueLength offers 4 unique tones. Using the “**UP/DOWN**” keys, the user can scroll through 1 of 4 tones. The tones generated are of audio frequencies to be used with tone tracers/probes. The signal generated on a pair is nominal 5volts peak-to-peak across the pair. **The unit will power down automatically after 1 hour.**

- 1) High Tone 1 KHz
- 2) Low Tone 704 Hz
- 3) Warble tones, low Tone for 160mS, followed by 115mS of High Tone
- 4) Warble tones, Low Tone for 365mS, followed by 65mS of High Tone.



Figure 6.

TEST LEAD CALIBRATION

- 1) Hold down the **“LEAD CAL”** key until the units displays **“CAL”**. The unit will display **“CAL”** for a few seconds then display **“Shrt LEAd”**.
- 2) Proceed to short the leads as illustrated in figure 7. Once connected properly to the bus wire, the user must depress the **“LEAD CAL”** key again. Upon competition, the unit will beep and display **“OPEN LEAd”**.
- 3) Disconnect the leads from the short. With the test leads open press the **“LEAD CAL”** button. Upon competition, the unit will be beep and go into its normal mode of operation. This completes the calibration procedure. This procedure must be done correctly to ensure good measuring results.

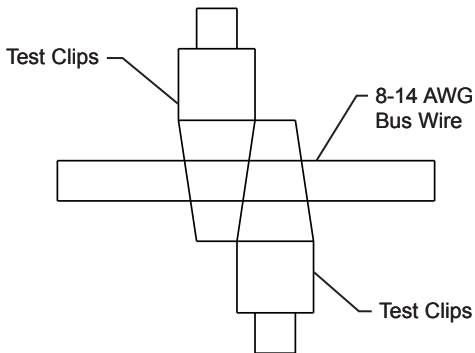

Figure 7. Wire

Note: Make sure the wire surface is clean and the clips are making good contact. For best results use solid wire 8 to 14 AWG. Make sure clips are as close together as possible as shown.

Models, options & accessories

Item	Ordering number
TrueLength cable length meter	CLM400
Replacement double banana to BNC + BNC to F jack	TP75
Replacement cordset and clips for CLM400	TP76
Pouch for CLM400	PC500

Battery Installation

Batteries are not included. Only Alkaline 9 volt battery should be used. When installing a new battery, disconnect any test cables connected to TrueLength. (See Figure 8)

- 1) Using a #2 Phillips screwdriver, unscrew the battery door screw and remove the battery cover on the back of the unit.
- 2) Remove the old battery out of the battery compartment and detach the battery cap.
- 3) Connect a new Alkaline 9 volt battery to the battery cap.
- 4) Slide the batteries into the cavity.
- 5) Close the battery cover and replace the screw. Do not overtighten.

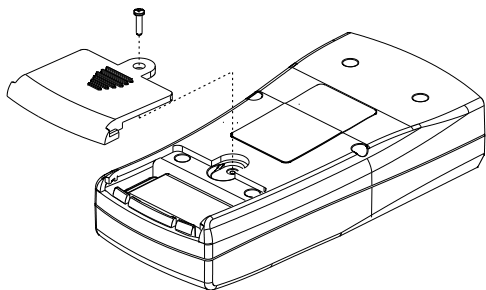

Figure 8.
Battery Installation

Specifications

Physical Dimensions

Size

3.3 x 7.6 x 15.2 cm

1.3 x 3.0 x 6.0 inches

Weight

326 grams (11.5 oz.)

Includes battery and test leads

Environmental

Operating temperature:

0 to 50 deg C (32 to 122 deg F)

Storage temperature:

-10 to 60 deg C (14 to 140 deg F)

Humidity:

10% to 90%, non-condensing

Battery Life

Battery life is based on a typical 9V alkaline battery

Standby: 2.5 years

Cable Testing: 20 hours into 60 Ohm load (Note: Smaller resistance loads will result in shorter battery life)

Cable Types

Singel or Dual conductor, AWG 8 - 30, mm 3.264 - .255, mm² 8.37 - .051, Network cabling, coax and telco.

High Voltage Protection

120vac max.

Length Measurement Range Opens/ Capacitance: Max .082uF

Wire Type	Typical Capacitance per Feet	Length	Tolerance
Telecom	17.5pf	0 - 1371 meters 0 - 4500 feet	Min. Cable Length 0.91 meter (3 feet) ±2%, +3 digits LSD
Network Wire	15.0pf	0 - 1524 meters 0 - 5000 feet	Min. Cable Length 0.91 meter (3 feet) ±2%, +3 digits LSD
Coax	22.0pf	0 - 1066 meters 0 - 3500 feet	Min. Cable Length 0.91 meter (3 feet) ±2%, +3 digits LSD

Length Measurement Range DC Resistance 0 - 635 ohms

AWG	Min. Feet	Length	Tolerance
8, 10	5.0	0 - 3047 meters 0 - 9999 feet	$\pm 2\%$, ± 3 LSD
12, 14, 16	4.0	0 - 3047 meters 0 - 9999 feet	$\pm 2\%$, ± 3 LSD
18, 20, 22	3.0	0 - 3047 meters 0 - 9999 feet	$\pm 2\%$, ± 3 LSD
24, 26, 28	1.0	0 - 3047 meters 0 - 9999 feet	$\pm 2\%$, ± 3 LSD
30	1.0	0 - 1792 meters 0 - 5879 feet	$\pm 2\%$, ± 3 LSD

LSD = Least Significant Digit.

Customer Services

This section provides a description of customer services available through JDSU (including returns policies and procedures) and warranty information.

Customer Service (Standard Services)

Customer Service accompanies the sale of every JDSU product. Customer Service services include:

- Technical Assistance (Business Hour)
- Instrument Repair (Under Warranty Repair, Calibration Services, and Upgrade Services)
- Immediate Return Authorizations

Technical Assistance Expert business hour technical support is included with your product.

Instrument Repair Our service centers provide repair, calibration, and upgrade services for JDSU equipment. JDSU understands the impact of equipment down time on operations and is staffed to ensure a quick turnaround. Available services include the following:

Product Repair — All equipment returned for service is tested to the same rigorous standards as newly

manufactured equipment. This ensures products meet all published specifications, including any applicable product updates.

Calibration — JDSU's calibration methods are ISO approved and based on national standards.

Factory Upgrades — Any unit returned for a hardware feature enhancement will also receive applicable product updates and will be thoroughly tested, ensuring peak performance of the complete feature set.

Equipment Return Instructions Please contact your regional Technical Assistance Center to get a Return or Reference Authorization to accompany your equipment. For each piece of equipment returned for repair, attach a tag that includes the following information:

- Owner's name, address, and telephone number.
- The serial number (if applicable), product type, and model.
- Warranty status. (If you are unsure of the warranty status of your instrument, contact Technical Assistance.)
- A detailed description of the

problem or service requested.

- The name and telephone number of the person to contact regarding questions about the repair.
- The return authorization (RA) number (US customers), or reference number (European Customers).

If possible, return the equipment using the original shipping container and material. If the original container is not available, the unit should be carefully packed so that it will not be damaged in transit; when needed, appropriate packing materials can be obtained by contacting JDSU Technical Assistance. JDSU is not liable for any damage that may occur during shipping. The customer should clearly mark the JDSU-issued RA or reference number on the outside of the package and ship it prepaid and insured to JDSU.

Warranty Information

JDSU guarantees that its products will be free of all defects in material and workmanship. This warranty extends for the period of 12 months for test instruments and 3 months for cables from date of manufacture or purchase (proof of purchase required).

All product deemed defective under this warranty will be repaired or replaced at JDSU's discretion. No further warranties either implied or expressed will apply, nor will responsibility for operation of this device be assumed by JDSU.



WEEE Directive Compliance

JDSU has established processes in compliance with the Waste Electrical and Electronic Equipment (WEEE) Directive, 2 002 /96/EC. This product should not be disposed of as unsorted municipal waste and should be collected separately and disposed of according to your national regulations. In the European Union, all equipment purchased from JDSU after 005 -08 -13 can be returned for disposal at the end of its useful life. JDSU will ensure that all waste equipment returned

is reused, recycled, or disposed of in an environmentally friendly manner, and in compliance with all applicable national and international waste legislation. It is the responsibility of the equipment owner to return the equipment to JDSU for appropriate disposal. If the equipment was imported by a reseller whose name or logo is marked on the equipment, then the owner should return the equipment directly to the reseller. Instructions for returning waste equipment to JDSU can be found in the Environmental section of JDSU's web site at www.jdsu.com. If you have questions concerning disposal of your equipment, contact JDSU's WEEE Program Management team at WEEE.EMEA@jdsu.com.

www.jdsu.com/know

Document Information

Doc. # TU9895

Revision 501, 09-08

English

