

Multi-Protocol Label Switching Transport Profile (MPLS-TP) Traffic Analysis

T-BERD®/MTS-6000A & 8000 MSAM CTMPLSTP(-U1)
 Ordering Information
 Use case

Verifying MPLS-TP services in packet transport networks (PTN)



Intended Audience

Central office and metro technicians responsible for MPLS-TP circuit installation, services turn-up, and fault troubleshooting.

Engineers responsible for the maintenance, troubleshooting and evolution of PTNs.

Applications: Installing, verifying, and troubleshooting MPLS-TP circuits carrying both customer and operations administration and maintenance (OAM) control plane traffic.

Solution Description

The MPLS-TP test option for the T-BERD/MTS-6000A & 8000 MSAM provides the ability to generate and analyze full line rate MPLS-TP data traffic for 10 Mbps to 10 Gbps PTN links. As a terminate or passive monitor application, it verifies key service level agreement (SLA) quality of service (QoS) metrics. It also supports comprehensive MPLS-TP OAM in compliance with both ITU-T pre-standard G.8114 and IETF draft MPLS-TP OAM based on Y.1731. By generating and monitoring OAM messages at pseudowire, label switched path (LSP), or section layer, operating with both label 13 or label 14, proper OAM operation can be verified.

Value Proposition

MPLS-TP, an emerging Layer 2 packet-based transport technology is critical to the successful deployment of Carrier Ethernet services driven by high-bandwidth, high-performance applications such as LTE, internet protocol (IP) video, and mobile backhaul. As service providers offer and install more packet-based MPLS-TP services for their customers, the JDSU software option provides a cost-effective method for verifying the installation of MPLS-TP services and circuits. The new JDSU test suite gives providers confidence that MPLS-TP services are delivered with true carrier-class QoS; with properly functioning end-to-end OAM; as well as protection switching. By providing both customer data and control plane traffic verification in one easy to use tool, the MPLS-TP test suite saves both installation and troubleshooting time and efforts. Simple to understand pass (green)/fail (red) results as well as detailed traffic and OAM statistics appeal to both expert and novice users.

Feature/Benefit Summary

Feature	Description	Advantage	Benefit
MPLS-TP line rate traffic generation	Configurable MPLS header service provider (SP) and customer labels	Flexibility to connect to any point within MPLS-TP network	Proactively verifies correct circuit provisioning before handling live traffic
MPLS-TP SLA/KPI analysis	Reports key metrics of throughput, frame loss, delay, and jitter	Provides repeatable and simple pass/fail results as well as detailed statistics	Ensures that service meets true customer QoS and removes guesswork in troubleshooting
Label 13 or 14 OAM message generation and monitoring	Continuity check (CC), loopback (LB), and alarm indication signal (AIS)	Multiple OAM types supported, encompassing all network possibilities	Guarantees proper OAM operation with flexible analysis and ubiquitous usage
Simultaneous MPLS-TP customer data and OAM traffic	Real-time OAM analysis with background traffic generation	Emulates true network operation by exposing utilization impact	Comprehensive troubleshooting analysis in one easy to use tool

Use Case: End-to-End Traffic and OAM Verification

The T-BERD/MTS-6000A & 8000 MSAM can be used to generate and analyze end-to-end MPLS-TP traffic by connecting a test set to a switch or router port on both the near and far end of the circuit. In this scenario, each test set is configured in terminate mode and is used to transmit test traffic emulating customer data in each direction. Detected test traffic can then be analyzed on each test set displaying key traffic metrics such as throughput (bandwidth utilization or CIR), frame loss (FL), round trip delay (FD), and jitter (FDV), as well as MPLS-TP header label information.

In this mode OAM control plane traffic can also be generated and analyzed for OAM verification at turn-up or for troubleshooting scenarios. Link connectivity can be verified using CCM and fault isolation can be identified using loopback/link trace.

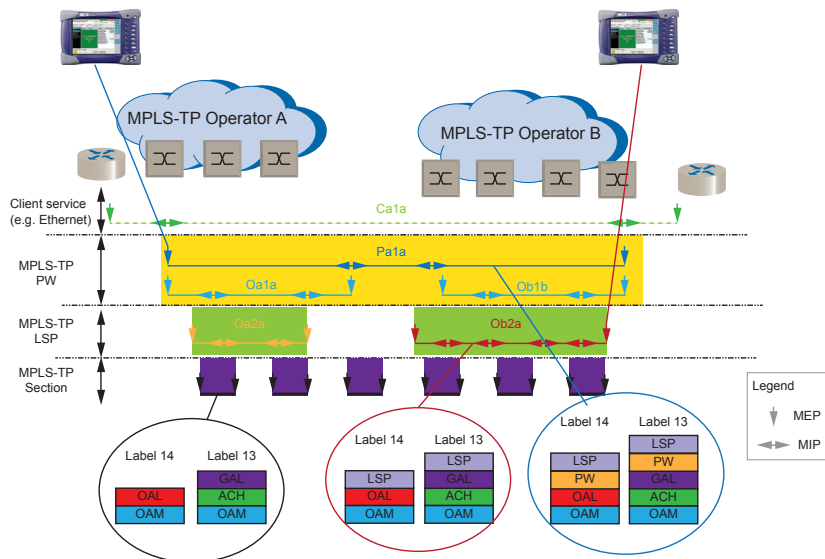

Use Case: Passive Monitor Mode

The T-BERD/MTS-6000A & 8000 MSAM can be used to monitor and analyze MPLS-TP traffic by connecting it to a mirror or spare port on a switch or router. In this scenario, the test set is configured in a passive monitor mode and is used to detect live MPLS-TP traffic that is forwarded to this mirror port by the switch. The discovered traffic can then be analyzed on the test set displaying key traffic statistics such as bandwidth utilization, received frame counts, and MPLS-TP header label information including service provider (SP) and customer label ID and priority.

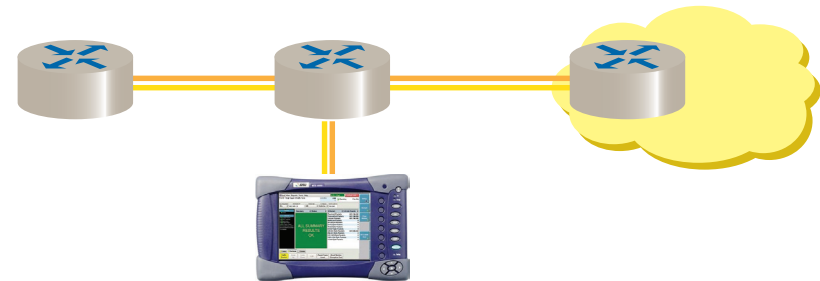

Simplified MPLS-TP Setup and Results

User configurable frame header labels are displayed in a clear graphical format for both SP and customer tunnel layers. Filters can be optionally set on the filters tab to further narrow down the detected traffic.

The analyzed traffic can be viewed using tables or graphs, presenting key SLA/KPI measurements and statistics. Errors are instantly revealed and indicated by red warnings, with histograms and absolute time graphs providing essential troubleshooting information.

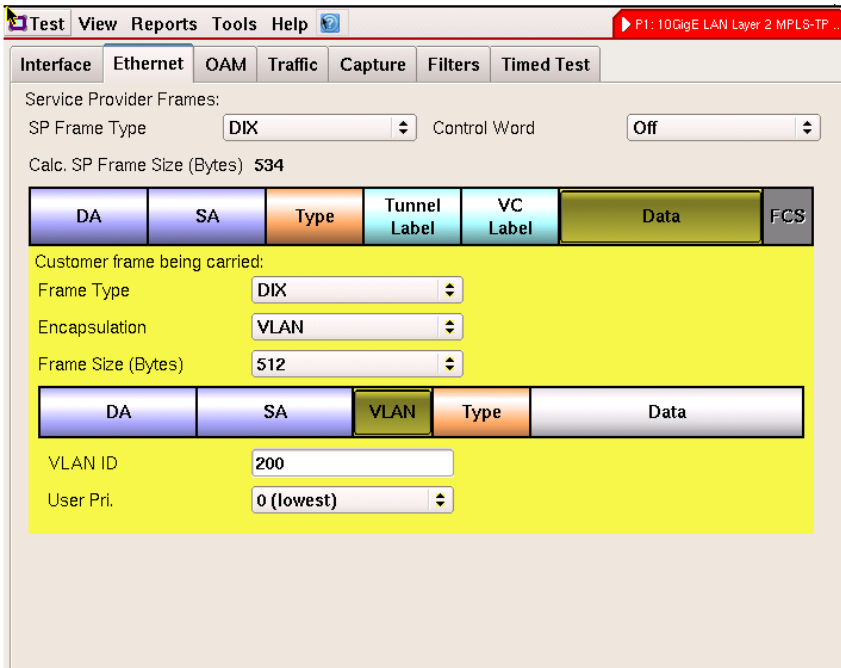

Test View Reports Tools Help P1: 10GigE LAN Layer 2 MPLS-TP ...

Interface Ethernet OAM Traffic Capture Filters Timed Test

Service Provider Frames:
 SP Frame Type **DIX** Control Word **Off**
 Calc. SP Frame Size (Bytes) **534**

DA	SA	Type	Tunnel Label	VC Label	Data	FCS
Customer frame being carried:						
Frame Type DIX						
Encapsulation VLAN						
Frame Size (Bytes) 512						
DA	SA	VLAN	Type	Data		
VLAN ID 200						
User Pri. 0 (lowest)						

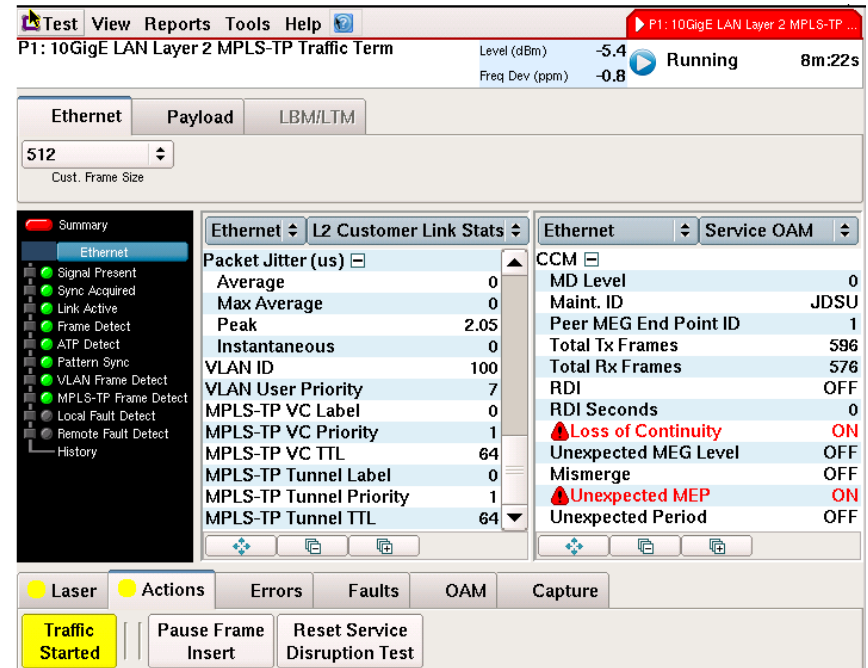

Test View Reports Tools Help P1: 10GigE LAN Layer 2 MPLS-TP ...

P1: 10GigE LAN Layer 2 MPLS-TP Traffic Term Level (dBm) **-5.4** Running 8m:22s
 Freq Dev (ppm) **-0.8**

Ethernet Payload LBM/LTM

512
 Cust. Frame Size

Ethernet	L2 Customer Link Stats	Ethernet	Service OAM
Summary			
<ul style="list-style-type: none"> Signal Present Sync Acquired Link Active Frame Detect ATP Detect Pattern Sync VLAN Frame Detect MPLS-TP Frame Detect Local Fault Detect Remote Fault Detect History 			
Packet Jitter (us)	Average 0	CCM	MD Level 0
Max Average 0	Peak 2.05	Maint. ID	JDSU
Instantaneous 0	VLAN ID 100	Peer MEG End Point ID	1
VLAN User Priority 7	MPLS-TP VC Label 0	Total Tx Frames	596
MPLS-TP VC Priority 1	MPLS-TP VC TTL 64	Total Rx Frames	576
MPLS-TP Tunnel Label 0	MPLS-TP Tunnel Priority 1	RDI	OFF
MPLS-TP Tunnel TTL 64		RDI Seconds	0
		Loss of Continuity	ON
		Unexpected MEG Level	OFF
		Mismerge	OFF
		Unexpected MEP	ON
		Unexpected Period	OFF

Laser Actions Errors Faults OAM Capture

Traffic Started Pause Frame Insert Reset Service Disruption Test

FAQ

Q: How is MPLS-TP different than MPLS?

A: MPLS-TP is a carrier-grade layer 2 packet based transport technology that has evolved over time in a joint effort by both the ITU-T and IETF, stemming from the IETF MPLS standard as its origin. It is a connection-oriented application with added mechanisms of critical transport functionality such as OAM and protection switching. MPLS-TP = MPLS – IP + OAM + PS. MPLS-TP has been developed by starting with MPLS, removing the IP (layer 3 routing), adding OAM, and adding protection switching.

Q: What are the benefits of MPLS-TP?

A: There are many benefits of MPLS-TP for transport service providers, which is why there is significant growth in the number of global MPLS-TP circuit installations. Some of these benefits include transparent multi-service support, high availability and sub 50 ms protection, end-to-end QoS, simple management and low cost of ownership, enhanced OAM, and high performance timing synchronization (3G/LTE).

Q: Why does this option support two different OAM types (label 13 and label 14)?

A: Both the ITU-T and IETF standards groups have specified their own versions of MPLS-TP OAM implementations, which function similarly and use different header labels. The ITU-T G.8114 draft standard uses OAM alert label (label 14) and the IETF draft specifies the alert label (label 13) plus the associated channel (ACH) based on Y.1731. The JDSU test suite supports both OAM implementations so that service providers are covered regardless of which method they implement in their network.

Q: Is this a software or hardware upgrade to existing units in the field?

A: The MPLS-TP option is a software upgrade that applies to all MSAM hardware configurations.

Q: Are there pre-requisites for this feature?

A: Yes, the MPLS-TP software option requires the 10M-1G Ethernet (CT10M1GE) or the 10GE LAN (CT10GELAN) or 10GE WAN (CT10GEWAN) options.